

Regular Meeting #18 - 2024
Fairfield County Commissioners' Office
May 7, 2024

Review Meeting

The Commissioners met at 9:00 a.m. in the Commissioners' Hearing Room located at 210 E. Main St., Lancaster, OH. Commissioner Levacy called the meeting to order, and the following Commissioners were present: Jeff Fix, Steve Davis, and Dave Levacy. County employees present: County Administrator, Aundrea Cordle; Deputy County Administrator, Jeff Porter; Clerk to the Commissioners, Rochelle Menningen; Communications & Information Coordinator, Bennett Niceswanger; Budget Director, Bart Hampson; JFS Director, Corey Clark; Facilities & EMA Director, Jon Kochis; Utilities Director, Tony Vogel; JFS Budget Director, Josh Crawford; ADAMH Executive Director, Marcy Fields; IT Tech Support, Xavier Smith; IT Service Desk Supervisor, Jimmie Gordon; CPS Program Administrator, Sarah Fortner; Social Service Worker, Dave Henwood; Deputy Director of Economic & Workforce Development, DeShawn Toney; Recorder Lisa McKenzie; Treasurer, Jim Bahnsen; Sheriff's Deputy, Tiffany Hedrick; Sheriff, Alex Lape; Deputy Director of Operations, Jason Grubb; Auditor, Dr. Carri Brown; Planner, Joshua Hillberry; Assistant Prosecuting Attorneys, Amy Brown-Thompson and Steven Darnell; IT Director, Dan Neeley; Economic Development Coordinator, Anthony Iachini; Prevention Coordinator, Toni Ashton; JFS Community Services Program Administrator, Krista Humphries, and also from JFS, Alice Shay, Stephanie Carson, Emily Sampson, and Heather Shields. Also present: Jonett Haberfield, Chris Schmelzer, Lindel Jackson, Ray Stemen, Chris Snider, Bryan Everitt, Mary Cullison, Sherry Pymmer, Francis Martin, Sherry Pymmer, Janet Haberfield, and Betty Bennett.

Virtual attendees: Josh Horacek, Tyler Monk, Tony Howard, Austin Lines, Joe Ebel, Greg Forquer, Melissa Connor, BGM, Lori Hawk, Shelby Hunt, Tiffany Daniels, Aubrey Ward, Park Russell, Jeff Barron, Deborah, Abby King, Belinda Nebbergall, Joe, Jeanie Wears, Nicole S., Jennifer Morgan, Andrea Spires, and Jerry Starner.

Welcome

Commissioner Levacy opened the meeting by welcoming everyone in attendance and spoke about the passing of former County Auditor, Barbara Curtiss Stiles.

Presentation of a Certificate and Proclamations

A Certificate was presented to Corporal Tiffany Hedrick for being selected to receive the 2024 Brett Markwood First Responder Award at the Lancaster Fairfield Chamber of Commerce Annual Dinner and Trade Show. Corporal Hedrick thanked the Commissioners for the certificate and spoke about the important interaction her position has with the community.

All veterans in attendance were asked to receive the proclamation for Military Awareness Month and Commissioner Levacy spoke about being born on the day the Germans surrendered in World War II.

Staff from Fairfield County ADAMH received the proclamation for Mental Health Awareness Month and the Director of ADAMH, Marcy Fields, spoke about the importance of supporting mental health awareness.

Anna Tobin, Director of Meals on Wheels for Fairfield County, accepted the proclamation recognizing May as Older Americans Month. Ms. Tobin thanked the Commissioners for their support and spoke about the variety of programs available to county residents 60 years and older.

Regular Meeting #18 - 2024
Fairfield County Commissioners' Office
May 7, 2024

Jonet Haberfield from Visit Fairfield County accepted the proclamation for National Travel and Tourism month and thanked the commissioners for their support in promoting tourism across the entire county.

Sheriff Lape and Corporal Hedrick accepted a proclamation for Peace Officers Memorial Day. Sheriff Lape thanked the Commissioners for their support of the Sheriff's department and thanked the men and women of the Sheriff's Office for keeping the community safe.

JFS Director, Corey Clark, along with Krista Humphries and Heather Shields, and staff from the fraud team, accepted the proclamation recognizing May as Public Assistance Fraud Awareness Month. Ms. Shields introduced the fraud investigators and Mr. Clark stated he will be giving an update on fraud investigations at an upcoming Commissioners' meeting.

Mr. Clark, Sarah Fortner, and Dave Henwood accepted the proclamation recognizing May as Foster Care and Adoption Recognition and Recruitment Month. Ms. Fortner and Mr. Henwood spoke about the number of children in foster care, and the difficult task the team has placing children in short and long term foster homes.

Listen & Learn – Hunter's Run Conservancy District

Director of the Hunter's Run Conservancy District, Lindell Jackson, stated that the Hunter's Run conservancy was formed in 1952, and in 1958 the Conservancy determined the dollar amount people in the area would pay to maintain the dams. There has not been a reappraisal done since 1958. Money was needed for a study and Fairfield County ARP money made it possible to get an assessment completed. There were 13,119 parcels within the watershed that were assessed. The indirect benefits are hard to explain, but everyone in the watershed area receives some benefit, even if their property does not flood. There is an economic benefit to all in the area. An H&H engineering study was done that shows what would happen if the dams were not in place and a lot of businesses are within the zone that have never been assessed. The ORC provides for a court hearing. Mr. Jackson thanked Jon Kochis and Garrett Blevins for helping with the May 6th open house meeting.

Commissioner Fix asked about the 21 dams in the conservancy and what the possible issues would be for Lancaster if the dams are not in place and maintained. He thanked Mr. Jackson and spoke about the improvements in the Conservancy District under his management.

Mr. Jackson spoke about the conservancy district covering where Hunter's Run joins the Hocking River and how the river could rise.

Mr. Kochis stated that before this conservancy district's creation of a board, EMA was responding to calls and the dive team was performing cleaning up duties.

Mr. Jackson added that the conservancy district's website contains a video, and the video was shown during the meeting. The video contains information about floods in 1913 and 1918 that resulted in the creation of conservancy districts

Public Comments

Ray Stemen of Lancaster spoke about the loss of his wife of 63 years and the battle between good and evil in our world. He read a prayer poem written by his late wife, Judy Stemen.

Regular Meeting #18 - 2024
Fairfield County Commissioners' Office
May 7, 2024

Sherry Pymer of Walnut Township spoke about the May 21st meeting that is scheduled to have a resolution regarding industrial solar exclusionary zones in Fairfield County.

Legal Update

None.

County Administration Update

- *The County Administration Update was provided by County Administrator, Aundrea Cordle, unless otherwise noted.*

Week in Review

Leadership Conference

The Fairfield County Leadership Conference will be held at the Liberty Center, next Tuesday, May 14th, from 8 a.m. to noon. Elected Officials, Department Heads, and Supervisors will meet to increase the organizational knowledge base of the county.

Board of Commissioners' May 14th Meeting

Next week's meeting will be at the Liberty Center, at 1:00 p.m., following the Leadership Conference.

Foster Parent Banquet

Fairfield County JFS, Protective Services hosted their annual Foster Parent Banquet last week. Thank you to all who choose to serve in this incredibly important and impactful way.

Highlights of Resolutions

Administrative Approvals

The review packet contains a list of administrative approvals.

Resolution Review

There are 22 resolutions on the agenda for the voting meeting.

Resolutions of note:

- A resolution authorizing the approval of proclamations. We have seven proclamations on the agenda for the Commissioners to approve. We are honored to have individuals from the Air Force, the Navy, JFS, ADAMH, Meals on a Wheels, the Sheriff's Office, and Visit Fairfield County to receive proclamations.
- A resolution to appropriate funds for a grant match for a grant from the Ohio Airport Grant Program/Ohio Department of Transportation.
- A resolution to approve and adopt the Fairfield County Road Design Manual for un-incorporated areas of the county. The hearing for the manual was held during the April 23, 2024, Board of Commissioners' meeting.

Regular Meeting #18 - 2024
Fairfield County Commissioners' Office
May 7, 2024

- A resolution from the Engineer's Office to approve an agreement with Terracon Consultants, Inc. for construction inspection and testing services.

Calendar Review/Invitations Received

- *The review of calendar items, invitations received, and correspondence received was provided by the Clerk to the Board of Commissioners, Rochelle Menningen.*
- Light Ohio Blue Ceremony, May 8, 2024, 5:30 p.m., The Tree Church, 721 N. Memorial Dr., Lancaster
- Lancaster Fairfield Chamber Awards and Annual Trade Show, May 9, 2024, 4:30 p.m., Fisher Catholic High School, 1803 Granville Pike, Lancaster
- Governor's Holocaust Commemoration, May 8, 2024, 2:00 p.m., Statehouse Atrium, 1 Capital Sq., Columbus

Correspondence Received

- Violet Township Zoning Office, Variance Application Case VAR-24-06, 13052 Ault Rd., Pickerington
- Correspondence Regarding Industrial Solar Projects
- Memo, Dr. Carri Brown, County Auditor, Subjects: The Finder Reference Tool; Internal Control Manual; & GIS Projects
- The Fairfield County Auditor's Map of the Month
- The Auditor's Wins of the Week
- Memo, Dr. Carri Brown, May 3, 2024, Subject: Financial Leadership Academy
- Lancaster Eagle Gazette, May 2, 2024, Jeff Barron, "Tiffany Hedrick Says She is Honored to be the First Female to Win the Brett Markwood Award"
- Lancaster Eagle Gazette, May 3, 2024, Jeff Barron, "Emily Cordle Honored to Receive Chamber of Commerce Young Professional Award for 2024"
- Lancaster Eagle Gazette, May 5, 2024, USA Today Network, "Chillicothe Transit System Director Takes Position with Lancaster-Fairfield Public Transit"
- Federal Emergency Management Agency, April 18, 2024, Case No. 14-05-4454V, Letter of Map Change
- Auditor's Ledger: News from the County Auditor's Office, April 2024

Old Business

Commissioner Davis spoke on the CCAO Regional meeting held the prior week and how he enjoyed the opportunity to present on things happening in Fairfield County.

Commissioner Fix stated Fairfield County is in the Central Region for CCAO. He commended Commissioners Davis and Levacy for their content rich presentations. He added that he received a lot of positive feedback from attendees.

Commissioner Levacy stated he is always interested in hearing more from his colleagues and from county officials around Ohio.

Regular Meeting #18 - 2024
Fairfield County Commissioners' Office
May 7, 2024

New Business

Commissioner Davis expressed his condolences for Ray Stemen's loss.

Sheriff Lape stated his office continues to work to provide the best services to county residents.

Treasurer Bahnsen spoke about reaching out to Senator Schaffer to voice support for SB 186 which helps the ongoing problem of delinquent taxes.

Auditor Brown congratulated all the Chamber award winners and highlighted her Map of the Month. She mentioned upcoming volunteer opportunities. Two of her staff recently were certified in CPR and she thanked everyone for meeting financial reporting deadlines.

Director Vogel thanked the real estate office for their help with tax exemptions. He also thanked Sheriff Lape for helping to locate the owner of an abandoned car located on Utility Office property.

Commissioner Levacy stated Fairfield County is fortunate to have an abundance of water.

Anthony Iachini spoke about the Workforce Center's graduation and added that there are several different trades with graduating students.

DeShawn Toney stated the summer camps at the Workforce Center will be starting soon.

Director Kochis stated the county will host Luke Bryan again this year and he will be assisting in preparations for the large scale event. He mentioned that the Records Center parking lot will be closed for repaving.

Director Clark stated the Annual Family Fun Fest is coming up which is open to everyone at no charge.

Regular (Voting) Meeting

The Commissioners continued to their voting portion of the meeting and the following Commissioners were present: Jeff Fix, Steve Davis, and Dave Levacy. County employees present: County Administrator, Aundrea Cordle; Deputy County Administrator, Jeff Porter; Clerk to the Commissioners, Rochelle Menningen; Communications & Information Coordinator, Bennett Niceswanger; Budget Director, Bart Hampson; JFS Director, Corey Clark; Facilities & EMA Director, Jon Kochis; Utilities Director, Tony Vogel; JFS Budget Director, Josh Crawford; ADAMH Executive Director, Marcy Fields; IT Tech Support, Xavier Smith; IT Service Desk Supervisor, Jimmie Gordon; CPS Program Administrator, Sarah Fortner; Social Service Worker, Dave Henwood; Deputy Director of Economic & Workforce Development, DeShawn Toney; Recorder Lisa McKenzie; Treasurer, Jim Bahnsen; Sheriff's Deputy, Tiffany Hedrick; Sheriff, Alex Lape; Deputy Director of Operations, Jason Grubb; Auditor, Dr. Carri Brown; Planner, Joshua Hillberry; Assistant Prosecuting Attorneys, Amy Brown-Thompson and Steven Darnell; IT Director, Dan Neeley; Economic Development Coordinator, Anthony Iachini; Prevention Coordinator, Toni Ashton; JFS Community Services Program Administrator, Krista Humphries, and also from JFS, Alice Shay, Stephanie Carson, Emily Sampson, and Heather Shields. Also present: Jonett Haberfield, Chris Schmelzer, Lindel Jackson, Ray Stemen, Chris Snider, Bryan Everitt, Mary Cullison, Sherry Pymmer, Francis Martin, Sherry Pymmer, Janet Haberfield, and Betty Bennett.

Regular Meeting #18 - 2024
Fairfield County Commissioners' Office
May 7, 2024

Virtual attendees: Josh Horacek, Tyler Monk, Tony Howard, Austin Lines, Joe Ebel, Greg Forquer, Melissa Connor, BGM, Lori Hawk, Shelby Hunt, Tiffany Daniels, Aubrey Ward, Park Russell, Jeff Barron, Deborah, Abby King, Belinda Nebbergall, Joe, Jeanie Wears, Nicole S., Jennifer Morgan, Andrea Spires, and Jerry Starner.

Pledge of Allegiance

Commissioner Levacy asked everyone to rise as able and led the Pledge of Allegiance.

Announcements

Ms. Menningen stated that the Regional Planning Commission had been contacted by the contractor of the bid award on the agenda regarding concerns, therefore, resolution 2024-05.07.r would be removed from the agenda.

Approval of Minutes for April 30, 2024

On the motion of Jeff Fix and the second of Steve Davis, the Board of Commissioners voted to approve the Minutes for the Tuesday, April 30, 2024, meeting.

Roll call vote of the motion resulted as follows:
Voting aye thereon: Jeff Fix, Steve Davis, and Dave Levacy

Approval of Resolutions from the Fairfield County Board of Commissioners

On the motion of Jeff Fix and the second of Steve Davis, the Board of Commissioners voted to approve the following resolutions from the Fairfield County Board of Commissioners:

- 2024-05.07.a A Resolution Authorizing the Approval of Proclamations
- 2024-05.07.b A resolution approving to Appropriate from Unappropriated into a major expense category for Grant Fund# 3034, subfund#8350 for the FY2024 Ohio Airport Grant Program/Ohio Department of Transportation (ODOT), Grant match transfer from the General Fund # 1001 & Advance from the General fund.
- 2024-05.07.c A resolution authorizing a fund to fund transfer for Fairfield County Job and Family Services (JFS) for the 2nd Quarter 2024 Allocation.
- 2024-05.07.d A resolution authorizing the approval of repayment of advances to the General Fund from the CHIP PY2021 grants.

Roll call vote of the motion resulted as follows:
Voting aye thereon: Jeff Fix, Steve Davis, and Dave Levacy

Approval of Resolutions from the Fairfield County Engineer

On the motion of Jeff Fix and the second of Steve Davis, the Board of Commissioners voted to approve the following resolutions from the Fairfield County Engineer:

Regular Meeting #18 - 2024
Fairfield County Commissioners' Office
May 7, 2024

- 2024-05.07.e A Resolution to Approve and Adopt the Fairfield County, Ohio, Road Design Manual, for Unincorporated Areas of Fairfield County, Ohio, Final Version Effective April 23, 2024
- 2024-05.07.f A resolution to appropriate from unappropriated in a major expenditure object category County Engineer 2024-Motor Vehicle for general office supplies
- 2024-05.07.g A Resolution to Approve an Agreement between Fairfield County and Terracon Consultants, Inc.
- 2024-05.07.h A Resolution to Approve a Change Order for the FAI-CR7-1.94 Refugee Road Intersection Safety Improvement Project
- 2024-05.07.i A Resolution to Approve the Contract with Russell Standard Corporation for the 2024 Crack Sealing Project
- 2024-05.07.j A Resolution to Approve the Contract with Asphalt Materials, Inc. for the Purchase of Liquid Asphalt
- 2024-05.07.k A resolution to request for appropriations for additional unanticipated receipts of Memo receipts and memo expenses for fund 2050 for annual inspections in various subdivisions as of 04/29/2024.
- 2024-05.07.l A resolution to request for appropriations for additional unanticipated receipts of memo receipts and memo expenses for fund 3445 BLO-36 bridge replacement
- 2024-05.07.m A resolution to approve a reimbursement for REA/GIS services as a memo expenditure for fund 2024 – Motor Vehicle
- 2024-05.07.n A Resolution to Approve the Notice to Commence for the 2024 Crack Sealing Project
- 2024-05.07.o A Resolution to Approve the Notice to Commence for the Purchase of Liquid Asphalt

Roll call vote of the motion resulted as follows:
Voting aye thereon: Jeff Fix, Steve Davis, and Dave Levacy

Approval of Resolutions from Fairfield County Job and Family Services

On the motion of Jeff Fix and the second of Steve Davis, the Board of Commissioners voted to approve the following resolutions from Fairfield County Job and Family Services:

- 2024-05.07.p A resolution to approve a memo exp./ memo receipt for the costs of Birth Certificates paid to Fairfield County Health Departments as a memo expenditure for fund# 2072 Public Children's Services
- 2024-05.07.q A Resolution Regarding a Purchase of Services Contract between TeenWorks and Job & Family Services

Regular Meeting #18 - 2024
Fairfield County Commissioners' Office
May 7, 2024

Roll call vote of the motion resulted as follows:
Voting aye thereon: Jeff Fix, Steve Davis, and Dave Levacy

Approval of Resolutions from the Fairfield County Sheriff

On the motion of Jeff Fix and the second of Steve Davis, the Board of Commissioners voted to approve the following resolutions from the Fairfield County Sheriff:

- 2024-05.07.s A resolution to appropriate from unappropriated in a major expenditure object category for Sheriff's Office Fund 2027, Weights.
- 2024-05.07.t A resolution to appropriate from unappropriated in a major expenditure object category for Sheriff's Office Fund 2394, Litter.
- 2024-05.07.u A resolution to appropriate from unappropriated in a major expenditure object category for Sheriff's Office Fund 2442, Commissary.
- 2024-05.07.v A Resolution Authorizing the Disposal of Vehicles by Internet Auction with Gov Deals, Inc.

Roll call vote of the motion resulted as follows:
Voting aye thereon: Jeff Fix, Steve Davis, and Dave Levacy

Approval of the Payment of Bills

On the motion of Jeff Fix and the second of Steve Davis, the Board of Commissioners voted to approve the following resolution for the Payment of Bills:

- 2024-05.07.w A Resolution Authorizing the Approval of Payment of Invoices for Departments that Need Board of Commissioners' Approval

Roll call vote of the motion resulted as follows:
Voting aye thereon: Jeff Fix, Steve Davis, and Dave Levacy

Adjournment

With no further business, on the motion of Jeff Fix and the second of Steve Davis, the Board of Commissioners voted to adjourn at 10:10 a.m.

Roll call vote of the motion resulted as follows:
Voting aye thereon: Jeff Fix, Steve Davis, and Dave Levacy

The next Regular Meeting is scheduled for 1:00 p.m. on Tuesday, May 14, 2024, at the Liberty Center.

**THIS PAGE
INTENTIONALLY
LEFT BLANK**





AGENDA

BOARD OF COMMISSIONERS

Commissioners:
Steven A. Davis
Jeffrey M. Fix
David L. Levacy

Tuesday, May 7, 2024
9:00 a.m.

County Administrator
Aundrea N. Cordle

Deputy County Administrator
Jeffrey D. Porter

Clerk
Rochelle Menningen

1. Review

Purpose of Review Meeting: *To prepare for formal actions of county business, such as Commission resolutions, and to provide a time for county leadership to connect about matters of county business.*

2. Welcome

3. Introduction of New IT Team Member, Xavier Smith

4. Hunter's Run Conservancy District Assessment Update

Lindel Jackson

5. Public Comments

Purpose of Public Comments: *This is a time for voters and taxpayers (members of the public) to provide comments. There is a time limit of 3 minutes. While this is a time for comments to be provided, it is not a time for questions and answers. The Commission has a full agenda of county business.*

6. Legal Update

7. County Administration Update

- a. Week in Review
- b. Highlights of Resolutions
- c. Budget Review
- d. Recognitions/Thank-Yous
- e. Calendar Review/ Invitations Received
 - i. Light Ohio Blue Ceremony, May 8, 2024, 5:30 p.m., The Tree Church, 721 N. Memorial Dr., Lancaster
 - ii. Lancaster Fairfield Chamber Awards and Annual Trade Show, May 9, 2024, 4:30 p.m., Fisher Catholic High School, 1803 Granville Pike, Lancaster
 - iii. Governor's Holocaust Commemoration, May 8, 2024, 2:00 p.m., Statehouse Atrium, 1 Capital Sq., Columbus
- f. Correspondence
 - i. Violet Township Zoning Office, Variance Application Case VAR-24-06, 13052 Ault Rd., Pickerington
 - ii. Correspondence Regarding Industrial Solar Projects
 - iii. Memo, Dr. Carri Brown, County Auditor, Subjects: The Finder Reference Tool; Internal Control Manual; & GIS Projects
 - iv. The Fairfield County Auditor's Map of the Month

SERVE • CONNECT • PROTECT



A G E N D A

B O A R D O F C O M M I S S I O N E R S

Commissioners:
Steven A. Davis
Jeffrey M. Fix
David L. Levacy

County Administrator
Aundrea N. Cordle

Deputy County Administrator
Jeffrey D. Porter

Clerk
Rochelle Menningen

- v. The Auditor’s Wins of the Week
- vi. Memo, Dr. Carri Brown, May 3, 2024, Subject: Financial Leadership Academy
- vii. *Lancaster Eagle Gazette*, May 2, 2024, Jeff Barron, “Tiffany Hedrick Says She is Honored to be the First Female to Win the Brett Markwood Award”
- viii. *Lancaster Eagle Gazette*, May 3, 2024, Jeff Barron, “Emily Cordle Honored to Receive Chamber of Commerce Young Professional Award for 2024”
- ix. *Lancaster Eagle Gazette*, May 5, 2024, USA Today Network, “Chillicothe Transit System Director Takes Position with Lancaster-Fairfield Public Transit”
- x. Federal Emergency Management Agency, April 18, 2024, Case No. 14-05-4454V, Letter of Map Change
- xi. *Auditor’s Ledger: News from the County Auditor’s Office*, April 2024

8. Old Business

9. New Business

- a. Updates from Elected Officials in Attendance

10. Regular (Voting) Meeting

11. Adjourn

12. MCJDC Annual Meeting of the Board of Trustees, MCJDC 12:00 p.m.

13. MCJDC Joint Board of Commissioners’ Meeting, MCJDC 1:30 p.m.

S E R V E • C O N N E C T • P R O T E C T

Quarters Total 2021, Total 2022, Total 2023, & Quarter 1,2 2024 – American Rescue Plan Fiscal Recovery Funds, as of 4.30.2024.

From the \$30,606,902.00 received as the first and second tranche of fiscal recovery funds. \$29,355,902.97 has been appropriated, \$20,545,127.55 expended, \$7,000,467.62 encumbered or obligated.

12Project/Category		As of 4/30/24 Appropriations	As of 4/30/24 Expenditure	As of 4/30/24 Obligation
Public Health				
R15a	Public Health, PPE	199.90	199.90	0.00
R16a	Public Health, Medical Expenses	206,838.33	206,838.33	0.00
R16b	Public Health, COVID Medial Costs County Benefits Program	399,949.66	399,949.66	0.00
R17a	Public Health, Vaccination Clinic and Related Expenses	66,362.57	66,362.57	0.00
R17b	Public Health, Capital Investments and Public Facilities of the County	3,488,618.85	3,404,630.19	83,988.66
R17c	Public Health, Capital Investment for Air Quality Improvements	56,674.00	56,674.00	0.00
R17d	Public Health, Capital Investment for Health Equipment, Mobile Morgue	49,498.87	49,498.87	0.00
R17e	Public Health, Capital Investment for Sheriff Cruiser to Respond to Increased Violence	54,250.98	54,250.98	0.00
R18a	Professional Communications on Behalf of the Board of Health	34,577.94	34,577.94	0.00
R18b	Public Health, Creation of a Community Health Assessment (CHA)	48,943.10	48,943.10	0.00
R19a	Public Safety Payroll Support	1,600,361.39	1,422,878.16	0.00
R19b	Public Health Payroll Support	185,406.39	185,406.39	0.00
R19c	Other Public Sector Payroll Support	290,060.11	230,088.02	0.00
R110a	Mental and Behavioral Health	0.00	0.00	0.00
Subtotal Public Health		6,481,742.09	6,160,298.11	83,988.66
Negative Economic Impacts				
R210a	Emergency Assistance for Non-Profit Organizations, a Subgrant to the City of Lancaster	0.00	0.00	0.00
R210b	Emergency Assistance for Non-Profits, Subgrant The Lighthouse	120,000.00	120,000.00	0.00
R210c	Salvation Army	500,000.00	500,000.00	0.00
R210d	Habitat for Humanity	610,000.00	610,000.00	0.00

Quarters Total 2021, Total 2022, Total 2023, & Quarter 1,2 2024 – American Rescue Plan Fiscal Recovery Funds, as of 4.30.2024.

From the \$30,606,902.00 received as the first and second tranche of fiscal recovery funds. \$29,355,902.97 has been appropriated, \$20,545,127.55 expended, \$7,000,467.62 encumbered or obligated.

Project/Category		As of 4/30/24 Appropriations	As of 4/30/24 Expenditure	As of 4/30/24 Obligation
R210e	ADAMH/LSS Housing Projects	3,000,000.00	748,622.88	2,251,377.12
R210f	Harcum House	100,000.00	100,000.00	0.00
R211a	Subgrant for Tourism, Support for the Fairfield County Fair	499,996.00	499,996.00	0.00
R211b	Aid to Tourism, Travel, Hospitality	18,278.01	18,278.01	0.00
R29a	Emergency Assistance Business Planning	146,829.87	146,829.87	0.00
R213a	Support for Agriculture and the Growing Community	35,000.00	35,000.00	0.00
R213b	Technical Assistance for Townships & Others	400,000.00	286,854.84	112,500.00
R213c	Contracts for Services to Support Residents Suffering Effects of the Pandemic	96,700.00	96,700.00	0.00
Subtotal Negative Economic Impacts		5,526,803.88	3,162,281.60	2,363,877.12
R310a	Housing Support, Affordable Housing Strategic Plan	39,554.00	39,554.00	0.00
Subtotal Services Disproportionately Impacted Communities		39,554.00	39,554.00	0.00
Premium Pay				
R41a	Premium Pay, Premium Pay for Emergency Management Agency Workers	27,907.72	27,907.72	0.00
Subtotal Premium Pay		27,907.72	27,907.72	0.00
Infrastructure				
R52a	Clean Water: Centralized Collection and Conveyance, Airport	598,480.00	444,480.86	105,729.68
R52b	Clean Water: Centralized Collection and Conveyance, Walnut Creek Sewer District	750,000.00	0.00	750,000.00

Quarters Total 2021, Total 2022, Total 2023, & Quarter 1,2 2024 – American Rescue Plan Fiscal Recovery Funds, as of 4.30.2024.

From the \$30,606,902.00 received as the first and second tranche of fiscal recovery funds. \$29,355,902.97 has been appropriated, \$20,545,127.55 expended, \$7,000,467.62 encumbered or obligated.

Project/Category		As of 4/30/24 Appropriations	As of 4/30/24 Expenditure	As of 4/30/24 Obligation
R52c	Clean Water: Centralized Collection and Conveyance, Regional Lift Station	2,761,835.85	0.00	2,761,835.85
R56a	Clean Water, Stormwater	539,895.00	539,895.00	0.00
R511a	Drinking Water: Transmission/Distribution, Grant Hampton	894,729.11	800,318.61	0.00
R511b	Drinking Water: Transmission/Distribution, Airport	102,000.00	100,805.00	0.00
R511c	Drinking Water: Transmission/Distribution, Greenfield	1,900,000.00	0.00	0.00
R511d	Drinking Water: Transmission/Distribution, Baltimore	613,000.00	431,557.67	181,442.33
R511e	Drinking Water: Transmission/Distribution, Pleasantville	834,000.00	456,309.05	377,690.95
R516a	Broadband, "Last Mile" Projects	0.00	0.00	0.00
Subtotal Infrastructure		7,093,939.99	2,773,366.19	4,176,698.81
Revenue Loss				
R61a	SaaS and Technological Equipment	370,646.50	369,959.32	687.18
R61b	Recorder Document Scanning	337,984.72	337,984.72	0.00
R61c	Clerk of Courts Case Management	375,000.00	372,221.42	2,778.58
R61d	MARCS Tower Project	572,433.00	537,899.50	34,533.50
R61e	Dispatch Consoles	543,820.85	543,820.85	0.00
R61f	Fairfield Center Purchase	2,708,752.85	2,708,752.85	0.00
R61g	Fairfield Center Renovation	3,763,530.00	2,471,708.96	281,103.01
R61h	Community School Attendance Program	486,110.43	280,437.03	54,458.73

Quarters Total 2021, Total 2022, Total 2023, & Quarter 1,2 2024 – American Rescue Plan Fiscal Recovery Funds, as of 4.30.2024.

From the \$30,606,902.00 received as the first and second tranche of fiscal recovery funds. \$29,355,902.97 has been appropriated, \$20,545,127.55 expended, \$7,000,467.62 encumbered or obligated.

Project/Category		As of 4/30/24 Appropriations	As of 4/30/24 Expenditure	As of 4/30/24 Obligation
R61i	Workforce Center Expansion	0.00	0.00	0.00
R61j	Smart Growth	200,000.00	197,657.97	2,342.03
R61k	United Way and Dolly Parton's Imagination Library	25,000.00	25,000.00	0.00
R61l	Auditor Historical Records Scanning	0.00	0.00	0.00
R61m	Engineer's Radios	80,000.00	80,000.00	0.00
R61n	Auditor Printers	4,357.66	4,357.66	0.00
R61o	Auditor Copiers	11,893.30	11,983.30	0.00
R61p	Bremen ADA Ramps	26,954.00	26,954.00	0.00
R61q	Transportation School Education Vehicles	38,357.90	38,357.90	0.00
R517a	Beavers Field Utilities	37,346.77	36,606.46	0.00
Revenue Loss		9,582,277.98	8,043,701.94	375,903.03
Administration				
R71a	Administrative Expenses	603,677.31	338,017.99	0.00
Subtotal Administration		603,677.31	338,017.99	0.00
Grand Total		\$29,355,902.97	\$20,545,127.55	\$7,000,467.62

ADMINISTRATIVE AUTHORITY ITEMS
FAIRFIELD COUNTY COMMISSIONERS' OFFICE
APRIL 29, 2024 TO May 05, 2024

Fairfield County Commissioners

- AA.04.30-2024.a An Administrative Approval for the payment(s) of the United Health Care (UHC) invoice for the Fairfield County Self-Funded Health Benefits Program – Fairfield County Board of Commissioners [Commissioners]
- AA.05.01-2024.b An Administrative Approval for the payment of invoices for departments that need Board of Commissioners' approval and have bills presented that are not more than \$75,000 per invoice. [Commissioners]

Fairfield County Family and Children First Council

- AA.04.29-2024.a Administrator Approval of a subgrant agreement amendment between the Ohio Department of Children and Youth (ODCY) and the Fairfield County Board of Commissioners as Administrative Agent for the Fairfield County Family and Children First Council for State Fiscal Year 2024 and State Fiscal Year 2025 [Family and Children First Council]

Fairfield County Job and Family Services

- AA.04.30-2024.b Administrative Approval to Amend the Fairfield County Compensation Plan [JFS]

Fairfield County Utilities Department

- AA.05.01-2024.a An administrative approval of a bank transfer for the County Utilities Department April 2024 [Utilities]

Governor Mike DeWine invites you to join him
for the 44th Annual



GOVERNOR'S HOLOCAUST COMMEMORATION



MAY 8, 2024 | 2:00 PM

STATEHOUSE ATRIUM | COLUMBUS, OH

FEATURING

The Japanese Diplomat who defied
orders to save Jewish lives

Governor DeWine in conversation with Chihiro
Sugihara and Sonia Milrod

Chihiro Sugihara carries on the legacy of his grandfather, Chiune Sugihara, a courageous Japanese diplomat. During World War II, Chiune, who served as consul in Lithuania, defied orders to save about 6,000 Jewish refugees from Nazi persecution by issuing transit visas through Japan. For his actions, Chiune received the title "Righteous Among the Nations." Chihiro, who lives in Thailand, honors his grandfather through speaking engagements worldwide.

Sonia Milrod, the daughter of Holocaust survivors, has a remarkable family story. Her father, Jerry Milrod, fled Łódź, Poland to Lithuania where a visa from Chiune Sugihara took him to Shanghai. Her mother, Lydia Hernball, escaped from Berlin after Kristallnacht, finding sanctuary in the same city. Their paths crossed in Shanghai, where they married before eventually settling in San Francisco. Now retired after a distinguished career in education, Sonia cherishes her role as a grandmother and dedicates her time to volunteering as part of the Nancy and David Wolf Holocaust & Humanity Center's Coppel Speakers Bureau.

Maj. Gen. (U.S. Army, retired) Deborah Ashenhurst, director of the Ohio Department of Veterans Services, in conversation with Ohio National Guard Military Historian Sgt. 1st Class Joshua Mann

Benediction by Rabbi Lisa Delson

Rabbi Lisa Delson is the rabbi at Temple Shomer Emunim in Sylvania.

In partnership with Ohio Jewish Communities and the Ohio Holocaust & Genocide Memorial & Education Commission



You are also invited to tour an exhibit about the "Righteous Among the Nations" from Yad Vashem

During the Holocaust, when Jews were targeted for extermination by the Nazi party, a small non-Jewish minority across Europe mustered extraordinary courage to uphold human values and to rescue hunted Jews with no expectation of remuneration. These individuals were designated as "Righteous Among the Nations" by Yad Vashem, the World Holocaust Remembrance Center in Jerusalem.

This exhibition from Yad Vashem, on display through May 31, features eight of those "Righteous" rescuers who saved Jewish lives during the Holocaust. It is located in the north hallway of the Ohio Statehouse outside the Governor's Office.





VIOLET TOWNSHIP ZONING OFFICE

10190 Blacklick-Eastern Road
Pickerington Ohio 43147
(614) 575-5560 • fax (614) 575-5562
www.violet.oh.us

April 30, 2024

Subject: Variance Application

Dear Property Owner:

The Violet Township Board of Zoning Appeals will hold a Public Hearing at 7:30 p.m. on Thursday, May 16, 2024 at the Violet Township Administrative Offices located at 10190 Blacklick Eastern Road, Pickerington to consider the following:

Case VAR-24-06: an application for variance filed by Joseph Bittinger, Jr. for property located at 13052 Ault Road, Pickerington, owned by Karen and Joseph Bittinger, Jr. This application requests a variance from the provisions of Violet Township Zoning Resolution Section 3AA4-05(A)(2) to allow the construction of three detached accessory structures which in combination with one or more accessory buildings will exceed the total floor area permitted for accessory structures on a lot greater than one acre in area.

This application is available for examination from Friday, May 3, 2024 through Thursday, May 16, 2024 inclusive, Mondays through Fridays, excluding legal holidays, during the hours of 8:00 a.m. to 4:30 p.m. at the Violet Township Administrative Offices, 10190 Blacklick-Eastern Road, Pickerington, Ohio 43147.

The person responsible for giving notice of this public hearing by publication is Kelly Sarko, Violet Township Zoning Inspector.

Violet Township Board of Zoning Appeals

Thomas Collins, Chair

From: [Vernon Allen](#)
To: [Contact Web](#)
Subject: [E] Industrial solar projects in Amanda township
Date: Tuesday, April 30, 2024 4:08:52 PM

CAUTION: This email originated from outside of the organization. Do not click links or open attachments unless you recognize the sender and know the content is safe.

Dear commissioners: Steven Davis,
Jeff Fix, & David Levacy,

We are very concerned about the proposed industrial solar project which borders our active grain farm & home on 3 sides: south to Barry Russell farm, west & north to brothers Timothy Allen & Jedediah Allen whose guardian James Stevenson signed their farm up for solar farm without their wanting it. That farm is cash rented to William Pontius on the west from us. Barry Russell is farming their north field by us.

We were never consulted about how it would impact our farm, or our family's lives. We are committed to preserving this farm as a farm.

Agriculture has had a prime Fairfield

County business presence since it's very first settlers, & agribusiness continues to have a strong Amanda Township & Fairfield County economic presence.

It is our hope that you create exclusionary zones in the unincorporated areas of Fairfield County to prevent utility scale solar projects.

Sincerely, Mr & Mrs Vernon (Eleanor) Allen, 9520 Reigle Rd., Amanda

David Levacy, Commissioner
Jeff Fix, Commissioner
Steve Davis, Commissioner
210 East Main Street, Room 301
Lancaster, Ohio 43130

Bill Yates, Trustee
Terry Horn, Trustee
Doug Leith, Trustee
11420 Millersport Road
Millersport, Ohio 43046

Dear Commissioners and Walnut Township Trustees,

I want to urge you to approve the permit application for the Eastern Cottontail Solar project being developed in Fairfield County.

The Eastern Cottontail Solar project represents tangible growth and development for Fairfield County. It generates sustaining annual revenues and construction jobs. As a resident of Fairfield, I am always in favor of supporting development within our community.

Eastern Cottontail Solar also brings benefits to critical municipal services, including schools and fire departments. These community benefits create opportunities for new businesses and more development in Fairfield County that positively impact our way of life.

In addition to the wonderful benefits our community would receive, Eastern Cottontail would ensure Ohio remains at the forefront of innovation. To maintain our reputation, we must continue to encourage development of all kinds, including diverse energy development such as solar, within our state.

Thank you.

Name: Sarah Boone 

Address: 411E 6th Ave
Lancaster OH 43130

cc: Ohio Power Siting Board

David Levacy, Commissioner
Jeff Fix, Commissioner
Steve Davis, Commissioner
210 East Main Street, Room 301
Lancaster, Ohio 43130

Bill Yates, Trustee
Terry Horn, Trustee
Doug Leith, Trustee
11420 Millersport Road
Millersport, Ohio 43046

Dear Commissioners and Walnut Township Trustees,

I am a resident of Fairfield County in favor of the proposed Eastern Cottontail Solar project.

Eastern Cottontail will be a clean, quiet neighbor to our county while bringing the advantages of expanding our tax revenues and producing energy necessary to power our homes and businesses. Many municipalities, including our schools, will profit greatly from the creation of this project.

This is a win-win for local taxpayers, reducing the burden of raising taxes through levies and ensuring the school has a robust revenue stream for years to come.

I am proud to be a part of supporting economic development that will have a lasting, positive impact on the education of our children within Fairfield County.

This project is a great opportunity to show support for the development of Fairfield in a responsible way that benefits our community.

I urge you to support Eastern Cottontail Solar.

Name: *Joshua Nelson*



Address: *411 E 6th Avenue
Lancaster, Ohio*

cc: Ohio Power Siting Board

From: [Steven Herron](#)
To: [Contact Web](#)
Subject: [E] Exclusionary zones for industrial Solar Projects
Date: Saturday, May 4, 2024 8:37:11 AM

CAUTION: This email originated from outside of the organization. Do not click links or open attachments unless you recognize the sender and know the content is safe.

Commissioners Davis, Fix, and Levacy,

I am sending you this email as a resident asking you to create exclusionary zones in unincorporated areas of Fairfield County to prevent utility scale solar projects. I live on Reigle Road as a Amanda Township resident in Fairfield County. Our home is right across the road (narrow road) from where a proposed solar field could be located.

Some of my concerns include:

- A negative impact on my family and quality of life. We bought our land from my late father/father-in-law (he farmed this land) to build our home on a quiet roadway to raise our family in what we felt was the best area. Our home/property has given us so many opportunities to make great memories with our family because of the vast farmland that our family owns/farms, and the quietness of country life. If solar fields are allowed to be constructed next to our home, the construction/location of the solar fields will greatly disrupt our lives and will forever lose the peace and beauty of our area that our children and I have grown to love. Please don't let this happen!
- My property rights need to be protected. I put my life on the line every day in the law enforcement profession, and have done so for over 27 years. This profession has presented its challenges, but has provided my family and I a great life. We chose to live and invest in this property in an area zoned as agricultural/residential for a reason to give my family and I the best life. With the amount of property tax that has been paid since owning our property in 2004, I strongly feel that our property rights need to continue to be protected. Please stand in the gap to make that happen!
- The construction of the solar field would cause a disruption to our lives. Having worked in a wide variety of areas, I have seen the disruption that this type of construction has brought to other areas. If you allow this to happen, the construction will bring a negative impact to our community. It will bring dust, excessive noise, an amount of traffic that this area has never seen, hundreds of strangers in the area (which will directly affect crime rates in our peaceful area), road damage, and disruption to our everyday lives. Please don't let this happen!
- The damage that this will cause to our farmland. As stated before, our father/father-in-law passed away in September 2023 at the age of 78. He farmed the land in this area his whole life and was concerned about the devastation these solar fields would bring to this area. His passion to farm spread to his sons which are my brothers/brother-in-laws. We have seen firsthand the great investment to farm this land in this area, and the quality of life that it has provided to their families and the community as a whole. As our father/father-in-law feared, it will produce a loss of prime farmland, damage to field tiles, and many other factors which will never be able to be farmed again due to soil

compaction and damage to topsoil. Please don't let this happen!

As one enrolled in a bachelor's program in Business administration and business owners, we understand the importance of infrastructure and evolving in areas to improve better service. Which is why we believe that there are other options to make this happen. With your impactful vote, it would force those seeking to do this the opportunity to explore other viable options. There has been expanded growth in warehouses and commercial buildings in the area. We believe the areas such as rooftops of homes, businesses and warehouses would be better options.

There are many other factors to consider but I am sure my fellow neighbors have expressed their concerns as well. I again ask you to create exclusionary zones in unincorporated areas of Fairfield County as soon as possible. I believe that Fairfield County can forge a path in this area that other counties have not chosen to accomplish.

Thank you for your time,

Steven and Lisa Herron
9307 Reigle Road SW
Amanda, Ohio 43102

From: [Scott Barr](#)
To: [Contact Web](#)
Cc: [Beth Cottrell](#)
Subject: [E] Solar issue
Date: Monday, May 6, 2024 6:37:42 AM

CAUTION: This email originated from outside of the organization. Do not click links or open attachments unless you recognize the sender and know the content is safe.

Dear Commissioners Levacy, Davis, and Fix,

Thank you once again for your leadership in the issues facing Fairfield County. It is apparent that the vast majority of our residents oppose industrial solar in the proposed projects. We value our farmlands, natural environment, and stable communities more than the transient cash and temporary jobs that the outside developers promise.

Your approach to the controversy is sensible, and we trust you will vote to establish exclusionary zones in all unincorporated areas of the county. IT IS THE RIGHT THING TO DO!

Sincerely,
Scott Barr
10830 Swope Rd.
Amanda

Get [Outlook for iOS](#)

CONFIDENTIAL COMMUNICATION: The foregoing message and/or the attachments hereto may contain or constitute confidential or protected communications. You should not copy, forward, or distribute this message to others without the permission of the sender. If you believe that you are not the intended recipient of this message, we urge you to delete it without retaining a copy and inform the sender of your action. Your cooperation is appreciated.

May 1, 2024

Board of Commissioners Fairfield County
210 East Main Street
Lancaster, Ohio 43130

RE: Exclusionary zones for Solar projects

Dear Commissioners Davis, Fix and Levacy:

I am sending this letter as a resident of Amanda Township asking you to create exclusionary zones in the unincorporated areas of Fairfield County to prevent utility scale solar projects. I live within 1 mile of proposed solar project.

Some of my concerns are loss of farmland, construction noise and damage to roads (cost to repair and maintain these roads) and reduction in my property value. My husband and I planted 20,000 trees almost 25 years ago. This has brought much wildlife to this area. I have lived in this area my entire life and do not want to lose our rural, farm way of life; the same as many of my neighbors.

I ask you to create exclusionary zones in the unincorporated areas of Fairfield County as soon as possible.

Thank you for your time.

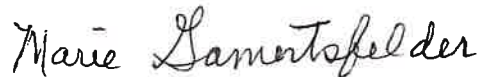

Marie Gamertsfelder
4415 Fosnaugh School Rd SW
Amanda, Ohio 43102
740-243-0983

Solar panels are dark and and they emit energy to the space above them when they are not being radiated. This is known as black-body radiation. Satellites flying in space use this phenomenon to cool internal components. If they didn't do this they would fry themselves.

So solar farms not only produce more heat in summer than the original land that they were installed on, but they also produce more cooling in winter, thus exacerbating weather extremes.

So I conclude with this. THERE IS NOTHING GREEN ABOUT GREEN ENERGY except the DIRTY MONEY flowing into corrupt pockets. There is no such thing as green energy. The science doesn't exist. The technology doesn't exist. The engineering doesn't exist. We

*Please!
This is not good
for our entire
existence!*

*The Hoover
family
Stout Rt. SW
AMANDA, OK*

To: Fairfield County Commissioners & Staff
From: Dr. Carri Brown, County Auditor
Date: May 2, 2024
Subjects: The Finder Reference Tool; Internal Control Manual; & GIS Projects



"The Finder" Reference Tool

Did you know you can use "The Finder" to look up tax information for addresses in Ohio? You can also identify a municipality or county for a property. Give it a try here: <https://tax.ohio.gov/help-center/the-finder/the-finder>

Internal Control Manual

We are thinking about updates to the internal control manual and are seeking input and feedback. When the new credit card policy is updated, that policy will be included in the updates. The manual now includes all relevant materials in one place. The beginning of the manual has a master listing of what is included in the manual. Current popular topics are separation of duties, fraud and risk management reporting, forms for multiple processes, and proper public purpose. ***This manual can be found on the [intranet](#) for employees.*** If anyone has any questions or would like a presentation for your department, please contact me.

GIS Projects

The Geographical Information Systems Department has taken on multiple new projects in support of county departments and the community. One top project is the public safety and 911 improvements. Other projects include support for agencies, conservancy districts, the public, and the US Census Bureau. We are currently gathering information in order to be proactive about support for the transition for public transit. While initial support relates to website development, future support will require managing changes to routes, which over time may become more voluminous. We are also gathering information about potentially interfacing with google which City officials indicate is quite burdensome. For that reason, we are gathering as much information as possible for planning purposes and to consider the new process overall.

GIS is also coordinating with schools to provide tours and presentations in order to help promote careers in GIS. Geographical information systems are essential tools for managing, analyzing, and visualizing spatial data. These tools play a critical role in multiple industries and have important functions and applications: spatial analysis; data visualization; resource management; urban planning; emergency response and public safety; environmental conservation; public health; transportation; business; agriculture; natural resource management; demographic and US Census analysis; land use and real estate valuation; conservation and ecology; and historical and cultural preservation. As we learn more about STEM classes and interest of the students, we can design an in-service or tour to complement curricula with real-world examples.

CONTACT US!

Settlements/Admin – (740) 652-7020 • Real Estate - (740) 652-7030
co.fairfield.oh.us/auditor • FairCoAuditor • FairfieldCountyAuditor • FairCoAuditor • fairfield-county-auditor

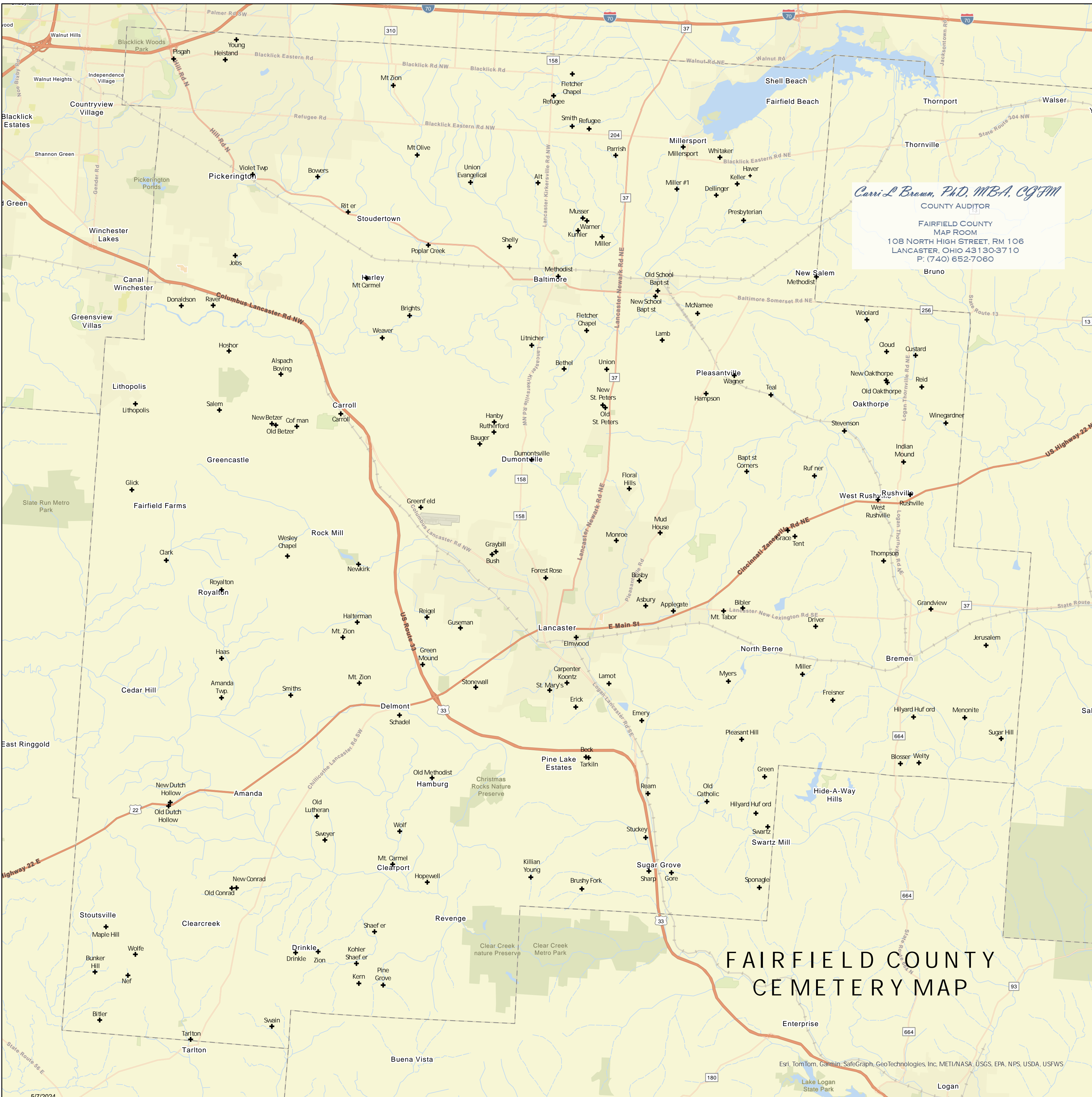

MEMORIAL DAY TRADITIONS

Memorial Day is an American holiday, observed on the last Monday of May, honoring the men and women who died while serving in the U.S. military.

Many Americans observe Memorial Day by visiting cemeteries and memorials. Some people wear a red poppy in remembrance of those fallen in war - a tradition that began with a World War I poem.

"In Flanders Fields" by John McCrae

In Flanders fields the poppies blow
 Between the crosses, row on row,
 That mark our place; and in the sky
 The larks, still bravely singing, fly
 Scarce heard amid the guns below.

We are the Dead. Short days ago
 We lived, felt dawn, saw sunset glow,
 Loved and were loved, and now we lie
 In Flanders fields.

Take up our quarrel with the foe:
 To you from failing hands we throw
 The torch; be yours to hold it high.
 If ye break faith with us who die
 We shall not sleep, though poppies grow
 In Flanders fields.

www.history.com

Volunteer Opportunity



"The purpose of the MIA Project is to locate, identify and inter the unclaimed cremated remains of American veterans through the joint efforts of private, state and federal organizations. To provide honor and respect to those who have served this country by securing a final resting place for these forgotten heroes."

Ohio has two National Cemeteries: Dayton & Ohio Western Reserve

Want to know more? Check out www.miap.us or contact Stephen Cihak at 614-571-8070



Your Fairfield County Auditor's Office: **WINS OF THE WEEK**

May 2, 2024

Our brains are wired to respond to rewards. Celebrating the completion of small accomplishments leads to the completion of larger goals. And there is evidence in research to support this...According to research by Teresa Amabile from Harvard Business School, tracking small achievements enhances motivation for larger goals ...

- In a little over a quarter, **418 GEMs** have been sent to coworkers within the office. Employees comment how these detailed little nuggets of encouragement are making a difference. Thanks for recognizing your coworkers for their good internal customer service and for sharing their expertise.

★ **Thanks to the GIS Team** for their exceptional work in answering requests for information and reports from multiple departments and separate political subdivisions, such as the Hunters Run Conservancy District and the Rushcreek Conservancy District. The requests for support can be quite involved, and the GIS team is tremendously efficient and competent in supporting these political subdivisions.

- Thanks to **JoJo Harmon, Michelle Wright, and Kit Burley** for their dedication to resolving issues surrounding the deductions for supplement life insurance. Thanks to the entire Payroll Team for their helpful communications.
- On Monday, we were able to review the BOR agenda for this week. We are on track to **complete the hearing season by the end of the month**. There may be some administrative activities to occur later in the year, but hearings will have been concluded.
- On Tuesday, we held an informational meeting with representatives of the Transportation Improvement District and Engineer's Office to continue discussions about a **major roadway project**. Carri followed up with a detailed memo, and Bev is working on engaging local government services of the State Auditor to ensure proper funding structures.
- The Commissioners held their weekly meeting in the evening at Wagnall's Memorial Library, and **Angel Horn** joined Carri at this meeting. Angel lives near the library and has often commented on the **beauty of the location**. Solar farms were a popular topic of comments from the public.
- The Finance team has been working diligently on the **Annual Comprehensive Financial Report**. Bev Hoskinson has made improvements to the **federal schedule reporting**. There is more work to be done with department officials, and the lines of communication are open.
- The **May Map of the Month**, created by **Stacy Knight**, highlights Memorial Day Traditions for honoring the fallen as well as over 150 cemeteries in Fairfield County.
- The annual meeting for the **Multi-County Juvenile Detention District** will be held in May, and a report for the boards of that district has been prepared.
- We continue to answer requests for help and support in reviewing grant opportunities following the free **grants workshop held at Ohio University Lancaster**.

★ Congratulations to **Meagen Bowland and Michele Poston** who are now certified with CPR and to all employees who have been engaged in the production and testing of the ASAP plans.

CONTACT US!

Settlements/Admin – (740) 652-7020 • Real Estate - (740) 652-7030

co.fairfield.oh.us/auditor • X FairCoAuditor • f FairfieldCountyAuditor • @ FairCoAuditor • in fairfield-county-auditor

5/7/2024

030



To: Commissioners and Staff
From: Dr. Carri L. Brown
Date: May 3, 2024
Subject: **Financial Leadership Academy**

We in the County Auditor's Office are still getting more surveys in about the financial leadership academy. We appreciate all the responses. As we continue to receive input, we wanted to let you know that there is a lot of interest in the academy.

There is so much interest that we will likely be conducting a core group of courses that are designed for all levels (including managers) and another group of courses for those who are charged with financial reporting and other financial functions, including grants management. We will be specifically inviting some departments who have responsibilities of grants management, such as the Major Crimes Unit, Parks District, and others.

In addition, there will likely be a unique group of courses for separate political subdivisions, such as townships and municipalities.

This will be a bigger effort than originally envisioned, and we plan to have the first courses in late 2024.

Stay tuned! We will be updating all elected officials and department heads.

Tiffany Hedrick says she honored to be the first female to win the Brett Markwood Award



Jeff Barron

Lancaster Eagle-Gazette

LANCASTER – Fairfield County Sheriff's Office Cpl. Tiffany Hedrick is the first female to win the Lancaster-Fairfield County Chamber of Commerce Brett Markwood Award.

She will receive her award at the chamber's annual awards banquet at 6:30 p.m. on May 9 at Fisher Catholic High School.

"I am truly, truly blessed and honored to be the one that's representing our sheriff's office to begin with and being the first female to actually receive this award," Hedrick said.



The annual Markwood Award honors local first responders. It is named after Brett Markwood, a city police officer killed on duty in 1993 while chasing a robbery suspect on Lincoln Avenue.

Hedrick didn't know Markwood, but she does know his sister.

"Every time that we go to a memorial and every time we go to places that are representing the fallen officers, the Markwood family is always there," she said. "It's one of those bittersweet moments. I wish it had never happened to their family, but I'm very honored to accept this award."

Hedrick works in the sheriff's community response unit and is also a firearms instructor.

Last year's winner: [Lancaster firefighter honored with Chamber award](#)

"The community response unit is the public relations for Sheriff Alex Lape," she said. "So we go out and do his public relations. Which is fairs, festivals, parades. We go out and teach to the citizens of Fairfield County. We do civilian response to emergency situation training to businesses. We also do self-defense for young girls and all the way up to seniors."

Hedrick's unit also works with seniors to help them avoid scams, among other things.

Hedrick has worked for the sheriff's office since 1998.

"I always wanted to be in law enforcement even when I was a little girl," he said. "Everybody always has things that have happened in their personal life. There have been some situations that evolved when I was younger that drove me to wanting to protect and serve Fairfield County. That's why I've always stayed here. I love this county and I never wanted to venture outside of where my hometown (Lancaster) is."



Hedrick said a good law enforcement officer must be willing to listen and be compassionate and caring.

"When people call law enforcement they're in probably the worst situation in their life at that moment," she said. "You have to respond and be able to try to make their life better and try to help the situation. Law enforcement is the best job ever. But you have to be a special person to be able to do this job."

The chamber's trade show will precede the awards banquet and will run from 4:30 to 6 p.m. at Fisher Catholic.

jbarron@gannett.com

740-681-4340

Twitter/X: @JeffDBarron

Emily Cordle honored to receive Chamber of Commerce Young Professional Award for 2024



Jeff Barron

Lancaster Eagle-Gazette

LANCASTER – Emily Cordle said it is a "huge honor" to receive the Lancaster-Fairfield County Chamber of Commerce's Young Professional of the Year Award.

"I'm so very thankful for everyone who nominated me," the South Central Power Company community relations specialist said. "I was completely surprised and just really humbled and glad and privileged to be part of an amazing community that has this award."



She will receive her award at the annual chamber awards banquet at 6:30 p.m. on May 9 at Fisher Catholic High School.

Cordle, who recently worked for the United Way of Fairfield County, said her community involvement may be a reason the chamber selected her for the award.

"I have been heavily involved through United Way, Lancaster Festival, Women's Giving Circle," she said. "I hold four board positions throughout the community. And I think networking is a huge one as well and trying to make an impact in any area I can."

Cordle serves on the boards of the Chase Haley Project, the Young Professionals, the local YMCA and Friends of Parks.

Last year's winner: Fairfield County resident awarded with Young Professional of the Year

She has a multitude of duties at South Central, including working on grants, scholarships, sponsorships and organizing volunteer opportunities for South Central employees, among other things.

Cordle said she enjoys serving others.

"Yes," she said. "From a young age, I was trailing my mom (Fairfield County Administrator Aundrea Cordle) to different volunteer events. That kind of transferred over to what I want to do in life. I'd always felt very honored to serve this community. To volunteer in any way possible to fill a need if it was needed."

Cordle advised other young professionals to network and volunteer as much as possible.

"Find the different organizations and find the ones that really resonate with you," she said. "Then just see what's out there and what's happening."

The chamber's trade show will precede the banquet from 4:30 to 6 p.m. at Fisher Catholic.

jbarron@gannett.com

740-681-4340

Twitter/X: @JeffDBarron

Chillicothe Transit System director takes position with Lancaster-Fairfield Public Transit

Lancaster Eagle-Gazette

USA TODAY NETWORK

LANCASTER — Lancaster-Fairfield Public Transit (LFPT) has hired a new director -- Aaron Kennedy.

Kennedy has spent the last several years at the Chillicothe Transit System, overseeing innovative solutions and enhancing service efficiency.



“We are delighted to extend a warm welcome to Mr. Kennedy as the newly appointed director at Lancaster-Fairfield Public Transit,” said Fairfield County Commissioner Steve Davis in a news release. “His extensive experience and innovative ideas position the County to take public transit to the next level to meet the needs of the County’s workforce. We look forward to the impact he will make.”

The team at Lancaster-Fairfield Public Transit welcomed Kennedy with enthusiasm, eager to hear his insights and how he will use his experience to make an impact on transit in Fairfield County. As the Lancaster-Fairfield Public Transit System transitions to become a Fairfield County department, the department is poised to enhance the current public transit system to serve residents and employers.

“I am honored and thrilled to join Lancaster-Fairfield Public Transit as the new director,” said Kennedy. “Fairfield County holds a special place in my heart, and I am excited to contribute to the community through innovative transit solutions. I look forward to collaborating with the dedicated team at LFPT and the County to further develop our public transit services and serve the needs of our community.”

Lancaster-Fairfield Public Transit System provided 128,489 passenger rides last year

Kennedy attended Ohio Christian University where he majored in business with a concentration in logistics. While pursuing his education, he gained practical experience in the public transit industry by joining the Chillicothe Transit System, first as the transit coordinator, then as the transit director.

He currently resides in Amanda, with his wife Sarah and their four children. Outside of work, he attends the Heritage Nazarene Church in Circleville where he sings with their praise team and volunteers with their small groups.



Federal Emergency Management Agency

Washington, D.C. 20472

April 18, 2024

Steve Davis
President, Fairfield County Board
of Commissioners
Fairfield City Commissioners' Office
210 East Main Street, Room 302
Lancaster, OH 43130

Case No: 14-05-4454V
Community: Fairfield County, OH
(Unincorporated Areas)
Community No.: 390158
Effective Date: April 26, 2024
LOMC-VALID

Dear President Davis:

On April 25, 2024, the Department of Homeland Security's Federal Emergency Management Agency (FEMA) issued new or revised Flood Insurance Rate Map (FIRM) panels within your community. This letter identifies the Letter of Map Change (LOMC) actions [i.e., Letters of Map Amendment (LOMAs) and Letters of Map Revision-based on Fill (LOMR-Fs)] for properties and/or structures located in your community that are still valid as of the effective date shown above. Any revalidation letters previously issued for your community have been superseded as of the effective date listed above.

All effective LOMCs within your community have been reviewed, including LOMCs located in areas not revised during this FIRM update. LOMAs and LOMR-Fs for which the original determination has not been superseded by new or revised information will remain in effect until superseded by a subsequent LOMC or by a revision to the FIRM panel on which the property and/or structure is located.

The enclosed table lists the FEMA case number, issue date, project identifier, and FIRM panel number for the LOMCs revalidated by this letter. Please refer to the original determination document to obtain the details of the outcome for the properties and/or structures included in the determination (such as flood zone, base flood elevations, property elevations, etc).

Letters of Map Revision (LOMRs) previously issued for FIRM panels that were revised by the recent map update for your community have either been incorporated into the revised FIRM or have been superseded by the revised FIRM. LOMRs issued for FIRM panels that were not revised by the recent map update for your community are not included on the enclosed table and will remain in effect until superseded by a revision to that FIRM panel.

If there is a LOMC not on the enclosed list that you feel should have been revalidated, we encourage you to submit the LOMC for re-determination. When requesting a re-determination, we ask that a cover letter be sent along with a copy of the original determination letter to: LOMC Clearinghouse, 3601 Eisenhower Avenue, Suite 500, Alexandria, VA 22304-6426. Re-determinations may also be requested online at <https://www.fema.gov/online-lomc>.

Because these revalidated LOMCs will not be reprinted or distributed to primary map users, such as local insurance agents and mortgage lenders, your community will serve as a repository for this information. We encourage you to disseminate the information reflected by this LOMC-VALID letter throughout your community so that interested persons, such as property owners, local insurance agents, and mortgage lenders, may benefit from the information.

Copies of previously issued LOMCs, if needed, may be obtained from your community's map repository, FEMA's Map Service Center website located at <https://msc.fema.gov>, or by contacting the FEMA Mapping and Insurance eXchange (FMIX), toll free, at 1-877-FEMA-MAP (1-877-336-2627).

For additional information or questions relating to LOMCs not listed on the enclosed table, or mapping in general, please contact the FMIX at the number provided above.

Sincerely,



Patrick "Rick" F. Sacbibit, P.E.
Chief, Engineering Services Branch
Risk Management Directorate | Resilience

cc: LOMC Subscription Service Subscribers
Community Map Repository
Joshua Hillberry, Regional Planner, Fairfield County Regional Planning

REVALIDATED LETTERS OF MAP CHANGE FOR FAIRFIELD COUNTY , OH
Case No: 14-05-4454V **Community No.: 390158**

April 26, 2024

Case No.	Date Issued	Identifier	FIRM Panel Number
95-05-1450A	8/3/1995	3065 GREENLAWN AVENUE	39045C0070G
96-05-1524A	6/6/1996	4802 COLONEL & PERRY DRIVE	39045C0070G
97-05-464A	11/13/1996	S.E. 1/4 SEC. 17 - 5400 GUN BARREL ROAD	39045C0190G
97-05-1336A	1/22/1997	2915 DUFFY ROAD	39045C0258G
97-05-5356A	10/23/1997	2300 STRINGTOWN ROAD - SECTION 19	39045C0165G
98-05-1600A	1/28/1998	560 OLD LOGAN ROAD - SECTION 33	39045C0254G
98-05-3742A	5/27/1998	7700 BUCKEYE ROAD	39045C0381G
99-05-562A	12/2/1998	PARCEL 2 - 4811 CHICKEN COOP HILL ROAD	39045C0270G
99-05-3024A	4/23/1999	TAYLORS SANDY BEACH ADDITION - LOTS 23 & 24 - 3704 SOUTH BANK RD	39045C0070G
99-05-5870A	8/25/1999	BATESON'S BEACH - LOT 16 - 5152 BATESON BEACH DRIVE	39045C0090G
99-05-7090A	10/27/1999	5488 CARROLL - NORTHERN ROAD NW	39045C0140G
00-05-1964A	3/28/2000	5724 OLD LOGAN ROAD, S.E.	39045C0268G
00-05-0412A	4/27/2000	2440 OLD LOGAN ROAD	39045C0254G

REVALIDATED LETTERS OF MAP CHANGE FOR FAIRFIELD COUNTY , OH
Case No: 14-05-4454V **Community No.: 390158**

April 26, 2024

Case No.	Date Issued	Identifier	FIRM Panel Number
00-05-2278A	6/20/2000	3298 SOUTH BANK ROAD	39045C0070G
00-05-4004A	10/18/2000	BATESON BEACH COTTAGE LOTS, LOT 18; 5182 BATESON'S BEACH DRIVE	39045C0090G
01-05-2485A	7/5/2001	12192 BUCKEYE POINT DRIVE, BUCKEYE POINT, LOT 9	39045C0070G
02-05-3417A	8/14/2002	LAKEVIEW BEACH, LOT 4; 3888 SOUTH BANK ROAD	39045C0070G
02-05-4134A	9/11/2002	PORTION OF SECTION 27, T17N, R18W; 12089 SUNSET VIEW DRIVE	39045C0070G
02-05-4594A	10/4/2002	29.963 ACRES, SECTION 16, SW 1/4, T16, R19; 9354 HEIMBERGER ROAD	39045C0135G
02-05-4496A	10/18/2002	S 1/2 OF SECTION 27, T17N, R18W; 12129 SUNSET VIEW DRIVE	39045C0070G
03-05-0157A	11/1/2002	SECTION 32, T15, R20; 6655 WATERLOO ROAD NW	39045C0110G
03-05-0297A	12/4/2002	FRY'S LAKEVIEW BEACH SUB'D, LOT 5; 3400 SOUTHBANK ROAD	39045C0070G
03-05-1188A	1/17/2003	HELENDORA SUBDIVISION, LOT 13; 3598 HELENDORA AVE.	39045C0070G
03-05-2759A	4/30/2003	LAKEWOOD PARK, LOT 20; 3186 MAPLE AVENUE	39045C0070G
03-05-2891A	6/6/2003	CLIMER'S GRANDVIEW ADDITION, LOT 11; 3274 SOUTHBANK ROAD	39045C0070G
03-05-4325A	8/8/2003	5242 BATESON BEACH DRIVE	39045C0090G

REVALIDATED LETTERS OF MAP CHANGE FOR FAIRFIELD COUNTY , OH
Case No: 14-05-4454V **Community No.: 390158**

April 26, 2024

Case No.	Date Issued	Identifier	FIRM Panel Number
03-05-5230A	9/24/2003	T15, R20, SECTION 35; 7120 LOCKVILLE ROAD	39045C0130H
03-05-5269A	9/24/2003	CLIMER'S GRANDVIEW BEACH, LOTS 9 AND 10; 3278 S. BANK RD.	39045C0070G
04-05-0839A	12/10/2003	TAYLOR'S SANDY BEACH, PORTION OF LOTS 11 & 12; 3788 SOUTH BANK ROAD	39045C0070G
04-05-0331A	12/12/2003	LLOYD'S SUB'D, LOT 1; 2805 COLUMBUS-LANCASTER ROAD	39045C0232G
04-05-0875A	1/9/2004	12119 SUNSET VIEW DRIVE	39045C0070G
04-05-1490A	1/14/2004	LAKWOOD PARK SUBDIVISION, LOTS 18 & 19; 3136 MAPLE AVENUE	39045C0070G
04-05-1619A	2/6/2004	C. M. WAGNERS ALLOTMENT, LOTS 8 & 9; 3174 SOUTH BANK ROAD	39045C0070G
04-05-2311A	5/5/2004	SECTION 22, TOWNSHIP 17, RANGE 18 ; 3755 WALNUT ROAD	39045C0070G
05-05-0288A	11/5/2004	6509 MILLERSIDING ROAD	39045C0190G
05-05-2401A	6/16/2005	7585 BASIL ROAD	39045C0153G
05-05-3166A	6/20/2005	LAKWOOD PARK SUBDIV, RESERVE 'E' -- 3200 FISHER AVENUE	39045C0070G
05-05-3763A	8/1/2005	PORTION OF SECTION 13, T19N, R18W	39045C0090G
05-05-4749A	10/4/2005	3878 SOUTH BANK ROAD -- PORTION OF SECTION 27, T17N, R18W	39045C0070G

REVALIDATED LETTERS OF MAP CHANGE FOR FAIRFIELD COUNTY , OH
Case No: 14-05-4454V **Community No.: 390158**

April 26, 2024

Case No.	Date Issued	Identifier	FIRM Panel Number
05-05-5009A	10/20/2005	HIGHLAND PARK PLACE, LOT 12 -- 2806 SALEM HILLS COURT	39045C0295H
06-05-BB90A	3/21/2006	TAYLOR'S SANDY BEACH SUBDIV, 1ST ADDITION, LOT 19 -- 3756 SOUTH BANK ROAD (OH)	39045C0070G
06-05-BN97A	6/13/2006	A.H. BROOKS WESTLAKE VIEW ADDITION, LOT 8 -- 12139 SUNSET VIEW DRIVE (OH)	39045C0070G
06-05-BU57A	10/5/2006	870 LEONARD ROAD -- PORTION OF SECTION 30, T16, R18 (OH)	39045C0154G
06-05-BY75A	10/5/2006	3739 OLD COLUMBUS ROAD -- PORTION OF SECTION 21, T15, R19 (OH)	39045C0145G
07-05-0342A	11/7/2006	LOTS 1, 2, AND 3S, HELENDORA -- 3528 HELENDORA AVENUE (OH)	39045C0070G
07-05-0361A	11/7/2006	4941 HARVEY LANE -- PORTION OF SECTION 23, R18, T17 (OH)	39045C0090G
07-05-0528A	12/12/2006	PORTION OF SECTION 27, T17N, R18W -- 12109 SUNSET VIEW DRIVE (OH)	39045C0070G
07-05-3129A	4/3/2007	LAKWOOD PARK, LEIBS ISLAND, LOTS 101 & 102 -- 3240 MIDDLE COURT NE (OH)	39045C0070G
07-05-4684A	7/3/2007	HELENDORA SUBDIVISION, LOT 14 -- 3606 HELENDORA AVENUE	39045C0070G
07-05-4920A	8/23/2007	TAYLOR'S SANDY BEACH ADDITION, LOTS 4 & 5 -- 3830 SOUTH BANK ROAD	39045C0070G
07-05-5727A	9/6/2007	3825 RICHLAND ROAD -- PORTION OF SECTION 3, T15, R18	39045C0170G
08-05-0191A	10/30/2007	9385 HILL ROAD NW -- LOT 1, HOMESTEAD HILL SUBDIVISION	39045C0110G

REVALIDATED LETTERS OF MAP CHANGE FOR FAIRFIELD COUNTY, OH
Case No: 14-05-4454V **Community No.: 390158**

April 26, 2024

Case No.	Date Issued	Identifier	FIRM Panel Number
08-05-0264A	10/30/2007	12199 SUNSET VIEW DRIVE -- PORTION OF SECTION 27, T17N, R18W	39045C0070G
08-05-2220A	3/6/2008	A.H. BROOKS WEST LAKE VIEW ALLOTMENT, PORTION OF LOT 5 -- 12099 SUNSET VIEW DRIVE	39045C0070G
08-05-2174A	3/25/2008	6750 WATERLOO ROAD -- PORTION OF SECTION 32, T15N, R20W	39045C0110G
08-05-2277A	3/25/2008	6900 WATERLOO ROAD -- PORTION OF SECTION 32, T15N, R20W	39045C0110G
08-05-2474A	3/25/2008	LAKEVIEW BEACH, LOTS 3 & 6-8 -- 3380, 3408, 3416 & 3424 SOUTH BANK ROAD	39045C0070G
08-05-2378A	4/15/2008	PORTION OF SECTION 32, T15N, R20W - - 6800 WATERLOO ROAD	39045C0110G
08-05-2911A	5/13/2008	TAYLOR'S SANDY BEACH, LOT 3-- 3848 SOUTH BANK ROAD	39045C0070G
08-05-3733A	6/17/2008	BROOK'S WEST LAKEVIEW SUBDIVISION, BLOCK 625, LOT 10--12159 SUNSET VIEW DRIVE	39045C0070G
08-05-4047A	7/10/2008	LAKWOOD PARK ADDITION, LOT 182 -- 3081 GREENLAWN AVENUE	39045C0070G
09-05-0276A	11/18/2008	SECTION 21, T15, R19, CONGRESS LANDS -- 3739 OLD COLUMBUS ROAD	39045C0145G
09-05-0922A	1/13/2009	4085 HORNS MILL ROAD -- PORTION OF SECTION 26, T14, R18	39045C0270G
09-05-1230A	1/29/2009	LAKWOOD PARK LEIB'S ISLAND, LOTS 165-166, 168, 203-204 & 206 -- 2977, 2981 & 2989 GREENLAWN AVENUE	39045C0070G
09-05-1409A	2/12/2009	CLIMERS GRANDVIEW BEACH SUBDIV, LOTS 4 & 5 -- 3322 SOUTH BANK ROAD	39045C0070G

REVALIDATED LETTERS OF MAP CHANGE FOR FAIRFIELD COUNTY , OH
Case No: 14-05-4454V **Community No.: 390158**

April 26, 2024

Case No.	Date Issued	Identifier	FIRM Panel Number
09-05-2000A	5/21/2009	7803 FAIRLAWN DRIVE -- PORTION OF SECTION 23, T16, R20, REFUGEE LANDS	39045C0040J
09-05-5358A	8/13/2009	6976 Waterloo Road	39045C0110G
10-05-0313A	10/20/2009	3895 Chicken Coop Hill Road	39045C0270G
09-05-6211A	10/22/2009	TAYLOR'S SANDY BEACH, LOT 14W -- 3776 SOUTH BANK ROAD	39045C0070G
09-05-6189A	11/24/2009	LOT 4 & 5 AND PORTION OF LOT 3, HELENDORA SUBDIV -- 3534 HELENDORA AVENUE	39045C0070G
09-05-5529A	12/18/2009	LOTS 172 & 210, RESERVE A OF LAKEWOOD PARK --3009 GREENWOOD AVENUE	39045C0070G
10-05-6283A	10/28/2010	LOTS 25 AND 26, TAYLOR'S FIRST ADDITION TO SANDY BEACH -- 3688 SOUTH BANK ROAD	39045C0070G
11-05-3265A	2/2/2011	2216 Campbell Lane	39045C0254G
11-05-3307A	3/22/2011	4200 HORNS MILL ROAD	39045C0270G
11-05-4914A	6/14/2011	2201 JOYE LANE	39045C0254G
12-05-1505A	12/13/2011	BUCKEYE LAKE RESERVOIR LANDS, LOT 23-319 -- 13404 ORCHARD ISLAND	39045C0090G
12-05-2817A	3/8/2012	LOT 23-246, PLAT OF BUCKEYE LAKE RESERVOIR LANDS -- 12544 WEST BANK DRIVE	39045C0070G
12-05-3349A	3/29/2012	4850 ELDER ROAD NORTHEAST	39045C0190G

REVALIDATED LETTERS OF MAP CHANGE FOR FAIRFIELD COUNTY , OH
Case No: 14-05-4454V **Community No.: 390158**

April 26, 2024

Case No.	Date Issued	Identifier	FIRM Panel Number
12-05-4902A	5/8/2012	SPRING CREEK CONDOMINIUM, BUILDINGS 12-20 & 22 -- KINGFISHER LANE & SANDPIPER LANE	39045C0040J
12-05-4310A	5/15/2012	SEC 31, T14, R18 -- 1161 MCGRERY ROAD SE	39045C0265H
12-05-4839A	5/15/2012	LOT 23-233, BUCKEYE LAKE RESERVOIR LANDS -- 12692 WEST BANK DRIVE	39045C0070G
12-05-3821A	5/17/2012	6135 ALLEN ROAD NORTHWEST	39045C0130H
12-05-6041A	5/31/2012	4546 CARPENTER ROAD	39045C0270G
12-05-5956A	6/6/2012	3425 Gun Barrel Road	39045C0190G
12-05-5945A	6/7/2012	1959 MARIETTA ROAD NORTHEAST	39045C0256G
12-05-4549A	7/3/2012	LOTS 1-2, A PRT OF LOTS 3-5, PLAT OF COTTAGE LOTS ADJOINING LAKE TOURIST HOTEL -- 4839 DECKER	39045C0090G
12-05-6987A	7/6/2012	AVENUE LOT 8, COMPASS POINT SUBDIVISION AND REPLAT OF KENNEY'S BEACH LOTS 15W & 16 -- 13796 ROSEWOOD DRIVE	39045C0090G
13-05-0240A	10/23/2012	2685 HORNS MILL ROAD	39045C0268G
13-05-2077A	2/21/2013	BUILDING 11, SPRING CREEK CONDOMINIUM -- 8059, 8063, 8067 AND 8071 KINGFISHER LANE	39045C0040J
13-05-0041A	3/12/2013	LOTS 4 AND 5, CLIFFORD B. STARNER'S HORN'S MILL SUBDIVISION -- 2845 HORNS MILL ROAD	39045C0268G
13-05-1601A	3/19/2013	2743 & 2751 HORNS MILL ROAD	39045C0268G

REVALIDATED LETTERS OF MAP CHANGE FOR FAIRFIELD COUNTY , OH
Case No: 14-05-4454V **Community No.: 390158**

April 26, 2024

Case No.	Date Issued	Identifier	FIRM Panel Number
13-05-3695A	3/21/2013	5780 REYNOLDSBURG BALTIMORE ROAD NORTHWEST	39045C0130H
12-05-5372A	4/23/2013	3333 Gun Barrel Road	39045C0195G
13-05-5970A	6/21/2013	Lot 3, Towpath Island Subdivision - 3245 Fisher Avenue	39045C0070G
13-05-5888A	6/25/2013	5815 SUGAR GROVE ROAD	39045C0268G
13-05-7629A	8/27/2013	LOT 2, CLIMERS GRANDVIEW BEACH ADDITION TO BUCKEYE LAKE -- 3346 SOUTH BANK ROAD	39045C0070G
13-05-6535A	9/10/2013	2715 HORNS MILL ROAD	39045C0268G
14-05-3310A	2/20/2014	8432 BENADUM ROAD NORTHWEST	39045C0110G 39045C0130H
14-05-6900A	6/10/2014	3126 South Bank Road Northeast	39045C0070G
14-05-7182A	6/20/2014	3787 Bickel Church Road	39045C0135G
14-05-9297A	10/30/2014	KENNY'S BEACH SUBDIVISION, LOT 2 & 2A -- 5900 KENNY DRIVE	39045C0090G
15-05-0956A	1/13/2015	13940 WAGRAM ROAD	39045C0040J
15-05-4514A	7/13/2015	SECTION 13, T14, R19 -- 375 HAMBURG ROAD	39045C0253H
15-05-5670A	9/2/2015	2240 & 2244 HORNS MILL ROAD SE	39045C0270G

REVALIDATED LETTERS OF MAP CHANGE FOR FAIRFIELD COUNTY , OH
Case No: 14-05-4454V **Community No.: 390158**

April 26, 2024

Case No.	Date Issued	Identifier	FIRM Panel Number
17-05-0347A	11/9/2016	Lot 12, Compass Point and Kenney's Beach Replat Subdivision - 13806 Rosewood Drive, NE	39045C0090G
17-05-3447A	6/8/2017	KENNEYS BEACH SUBDIVISION, LOT 3 -- 5890 KENNEY DRIVE NE	39045C0090G
17-05-4779A	6/13/2017	Lot 1 & 1A, Kenney's Beach Subdivision - 5910 Kenney Drive NE	39045C0090G
18-05-1329A	12/13/2017	Lot 10 / 23-279, C.M. Wagner's Allotment / Reservoir Lands Subdivision - 3192 South Bank Road NE	39045C0070G
18-05-2835A	3/9/2018	The Cottages at Compass Point Condominium, Unit H - 13848 Rosewood Drive	39045C0090G
18-05-6212A	10/11/2018	COMPASS POINT SUBDIVISION AND REPLAT OF KENNEY'S BEACH, LOT 7 -- 13794 ROSEWOOD DRIVE NE	39045C0090G
19-05-1156A	1/3/2019	The Cottages at Compass Point, Garage 3 Subdivision - 13854 Rosewood Drive	39045C0090G
19-05-2960A	5/22/2019	SECTION 36, T14, R18 -- 5295 HORNS MILL ROAD	39045C0270G
19-05-3941A	8/30/2019	KENNEY'S BEACH, LOTS 4 & 4A -- 5880 KENNEY DRIVE NE	39045C0090G
19-05-4191A	8/30/2019	BUCKEYE LAKE RESERVOIR LANDS, LOT 23-24 -- 4375 NORTH BANK ROAD NE	39045C0090G
20-05-1719A	4/3/2020	3743 Richland Road	39045C0170G
20-05-3279A	6/12/2020	Lot 11, Compass Point and Replat of Kenney's Beach Lots Subdivision - 13804 Rosewood Drive NE	39045C0090G
20-05-4647A	10/13/2020	COMPASS POINT SUBDIVISION & REPLAT OF KENNEY'S BEACH LOTS 15W & 16, LOT 6 -- 13792 ROSEWOOD ROAD NE	39045C0090G

REVALIDATED LETTERS OF MAP CHANGE FOR FAIRFIELD COUNTY , OH
Case No: 14-05-4454V **Community No.: 390158**

April 26, 2024

Case No.	Date Issued	Identifier	FIRM Panel Number
21-05-1034A	1/6/2021	Lot 29 - 30, Plat of Roby Subdivision - 13536 McLeish Street NE	39045C0070G
21-05-1062A	3/4/2021	Lot 5, Kenney's Beach Replat Subdivision - 5870 Kenney Drive NE	39045C0090G
21-05-4212A	9/15/2021	Lot 9, Hamilton Farm Subdivision - 3947 Hamilton Drive NE	39045C0070G
22-05-0590A	12/1/2021	The Cottages at Compass Point Condominium Subdivision - 13828 Rosewood Drive	39045C0090G
22-05-1273A	2/16/2022	Lot K, The Cottages at Compass Point Condominium Subdivision - 13860 Rosewood Drive	39045C0090G
22-05-1446A	3/2/2022	Lot 23-33, Buckeye Lake Reservoir Lands Subdivision - 4321 North Bank Road	39045C0090G
22-05-1609A	3/22/2022	Lot 23-326, Buckeye Lake Reservoir Lands Subdivision - 12740 Keller Island, NE	39045C0070G
23-05-0359A	11/28/2022	Lot 13, Compass Point and Replat of Kenney's Beach Subdivision - 13808 Rosewood Drive NE	39045C0090G
23-05-0360A	12/22/2022	Lot 14, Compass Point and Replat of Kenney's Beach Subdivision - 13810 Rosewood Drive NE	39045C0090G
23-05-0274A	1/11/2023	SECTION 14, T17, R18 & SECTION 23, T27, R18 -- 4493 NORTH BANK ROAD NE	39045C0090G
24-05-0148A	1/23/2024	BUCKEYE LAKE RESERVOIR LANDS, LOT 23-199 -- 13006 WEST BANK DRIVE NE	39045C0070G
24-05-0522A	2/8/2024	A.H. BROOKE'S WESTLAKE VIEW, LOT 13 -- 12189 SUNSET VIEW DRIVE NE	39045C0070G

AUDITOR'S LEDGER:

News from the County Auditor's Office

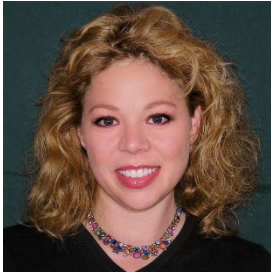

From the Desk of County Auditor Carri Brown

Spring has sprung in Fairfield County and we are enjoying the blooming trees and spring flowers at our building and throughout the area. It's such an exciting time of year, as we wrap up school, plan special celebrations and prepare our plans for the summer.

Speaking of celebrations, the Fairfield County Auditor's Office is excited to share two special recognitions we received recently. First, an Award for Outstanding Achievement in Popular Annual Financial Reporting from the Government Financial Officers Association. And second, a recognition we are incredibly proud of, the Auditor's Office was voted #1 in "The Best Places to Work" in the Fairfield County Community's Choice Awards! You can learn more about both awards in the stories below.

We have several updates to share with you in this newsletter, including information about the updated Board of Revision Handbook and online resources, hotel and lodging taxes that benefit local tourism, and a local survey we are asking public agencies and elected officials to complete so we can gauge interest in a financial leadership academy for entry-level and higher financial positions within local government.

In addition, we have our map of the month, a variety of community connections to share, opportunities to learn a bit more about some of the Auditor's Office staff, and important dates coming up in May.

If you missed a previous issue of our newsletter, you will find all of them posted online. We encourage you to visit our websites for ongoing updates and important information:

- [General County Auditor Information](#)
- [Real Estate Assessment Information](#)

Kindest regards,

A handwritten signature in blue ink that reads "Carri L. Brown".

Carri Brown, PhD, MBA, CGFM
County Auditor

News From the Auditor's Office

Fairfield County Receives GFOA Award for Achievement in Popular Annual Financial Reporting (PAFR)

The Government Finance Officers Association of the United States and Canada (GFOA) has given an Award for Outstanding Achievement in Popular Annual Financial Reporting to Fairfield County for its Popular Annual Financial Report for the fiscal year ended December 31, 2022.

The Award for Outstanding Achievement in Popular Annual Financial Reporting is a prestigious national award recognizing conformance with the highest standards for preparation of state and local government popular reports.

In order to receive an Award for Outstanding Achievement in Popular Annual Financial Reporting, a government unit must publish a Popular Annual Financial Report, with content conforming to program standards of creativity, presentation, understandability, and reader appeal.

Dr. Carri L. Brown, County Auditor, stated, “The Popular Annual Financial Report is a way to make the County’s financial statements more accessible to the public. The dedicated staff of our Finance Team works every day to ensure that we maintain fiscal responsibility in collaborative ways. We are proud of their achievement and recognition.”

View the report [here](#).

View the press release [here](#).

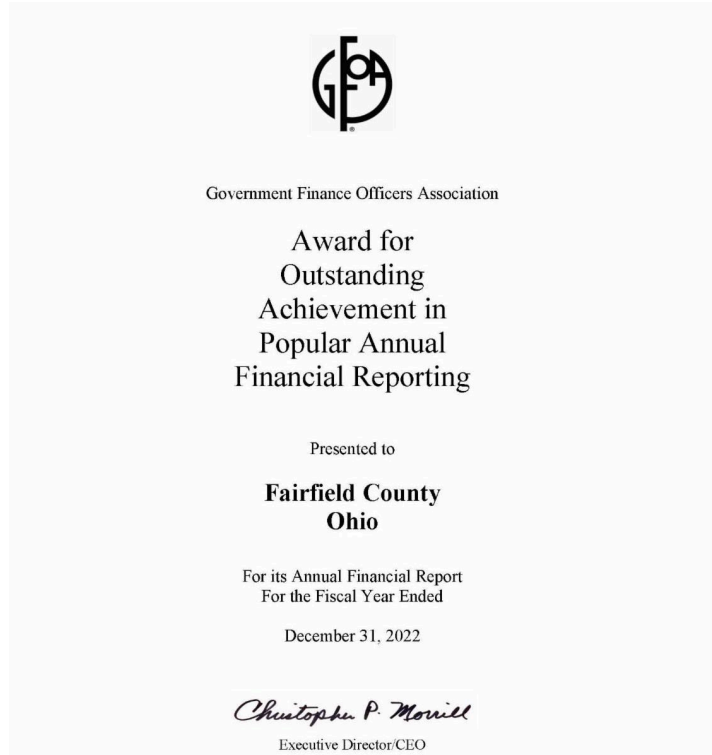

Fairfield County Auditor's Office Voted Best Place to Work



The official Community's Choice Awards of Fairfield County, hosted by the *Lancaster Eagle Gazette*, honor and celebrate local businesses with a contest that allows the community at large to select their favorite businesses in a variety of categories - from dining and services to education and top workplaces. The program launched on December 1, 2023 and winners were just recently announced. The Fairfield County Auditor's Office is proud to be the winner of the Top Employers - Places to Work category. We appreciate everyone who took the time to vote!

Congratulations to all award honorees and thank you to all Fairfield County collaborators.

Creation of the Updated Ohio Board of Revision Practice Handbook and Online Resources

Fairfield County is pleased to support the creation of the updated *Ohio Board of Revision Practice Handbook*. This handbook is widely used throughout the state as a resource for Ohio County Boards of Revision, practitioners, and residents.

It is accompanied by an online resource, the Ohio Board of Revision Resource Center, at <https://www.co.fairfield.oh.us/OBPRRC>. These online tools are additional ways to support the public and those who serve the public.

“Having served on the Board of Revision for more than a decade, first as a delegate of the President of the Board of County Commissioners, and for the past three years as the County Auditor, I can attest to the usefulness of these exceptional resources. Also, in multiple conferences and meetings, officials from other counties have reported how important these resources are to them and to real property owners,” stated Dr. Carri L. Brown, County Auditor.

Auditor Brown thanked Jason M. Dolin, Esq., for his ongoing leadership and consultation. Jason initiated the work to create these valuable resources, and he continues to be passionate about the effort. He has been a mentor to Fairfield County's Board of Revision Administrator, Linda O'Toole, Esq., who joined our office in 2022.

With the handbook and online tools, real property owners and their representatives have more information available to help them navigate processes surrounding the valuation of real property. Professionals in the field also have readily available information to support them in their roles.

Our office will continue our support of this comprehensive effort to benefit public services in our county and in the state.

Potential Financial Leadership Opportunity

The Fairfield County Auditor's Office is reaching out to public agencies and elected officials to inquire about the possibility of developing a financial leadership academy for entry level and higher financial positions within local government. Due to the ranging education levels and professional backgrounds of employees who enter these roles, it has been identified that a more standardized level of training could benefit working relationships within and across local government entities.

In this vision, The Auditor's Office would lead the necessary training around relevant processes, procedures and terminology to equip professionals with a consistent knowledge base. The Auditor's Office intends to provide the training at no cost.

Before moving forward with this concept, we want to gauge interest on such a training and gather feedback on the structure and timing of the prospective program.



Take the Survey

Travel & Tourism Week is May 19-25

Did you know the County Auditor collects hotel/motel lodging taxes?

In July 1981, the Board of Fairfield County Commissioners passed a resolution to establish a 3% collection of lodging excise tax. This tax supports the Fairfield County Visitors and Convention Bureau (Visit Fairfield County). In September 1993, another resolution was passed to establish an additional 1.5% lodging excise tax for the Decorative Arts Center of Ohio (DACO). The 1.5% lodging excise tax is effective through 2027 - unless there is a legislative change.



In December 2021, the Commissioners amended the definition of a hotel to include lodging establishments with fewer than five rooms or establishments with rooms that are used for guests, regardless of whether each room is accessible through its own key. This includes using Airbnb and other types of short-term lodging reservation platforms, as well as traditional hotels.

There are currently 10 traditional hotels and approximately 45 short-term rental establishments participating. The Auditor's Office uses technology to locate short-term lodging entities with sales and collects the taxes using an online process. There is no permitting process in Fairfield County for short-term lodging and townships are responsible for zoning.

On average, \$350,000 is collected annually for the Visit Fairfield County and \$230,000 is collected annually for DACO. Each of these organizations supports tourism and travel to Fairfield County, focusing on what makes our county unique. The uses of the revenues for these organizations are outlined in the ORC and as enacted by local legislation.

Visit the [Decorative Arts Center of Ohio](#) and [Visit Fairfield County](#) to learn more about the activities of these organizations.

Community Connections

May Map of the Month - Fairfield County Cemeteries and Memorial Day Traditions

The May Map of the Month features cemeteries throughout Fairfield County and how many Americans observe the holiday by visiting cemeteries and memorials. Poppies are also worn in remembrance of the fallen during war - a tradition that began with a World War I poem by Jon McCrae.

"In Flanders Fields" by John McCrae

*In Flanders fields the poppies blow
Between the crosses, row on row,
That mark our place; and in the sky
The larks, still bravely singing, fly
Scarce heard amid the guns below.*

*We are the Dead. Short days ago
We lived, felt dawn, saw sunset glow,
Loved and were loved, and now we lie
In Flanders fields.*

*Take up our quarrel with the foe:
To you from failing hands we throw
The torch; be yours to hold it high.
If ye break faith with us who die
We shall not sleep, though poppies grow
In Flanders fields.*

There are an estimated 150 cemeteries in Fairfield County. For a larger version of the map, click [here](#).

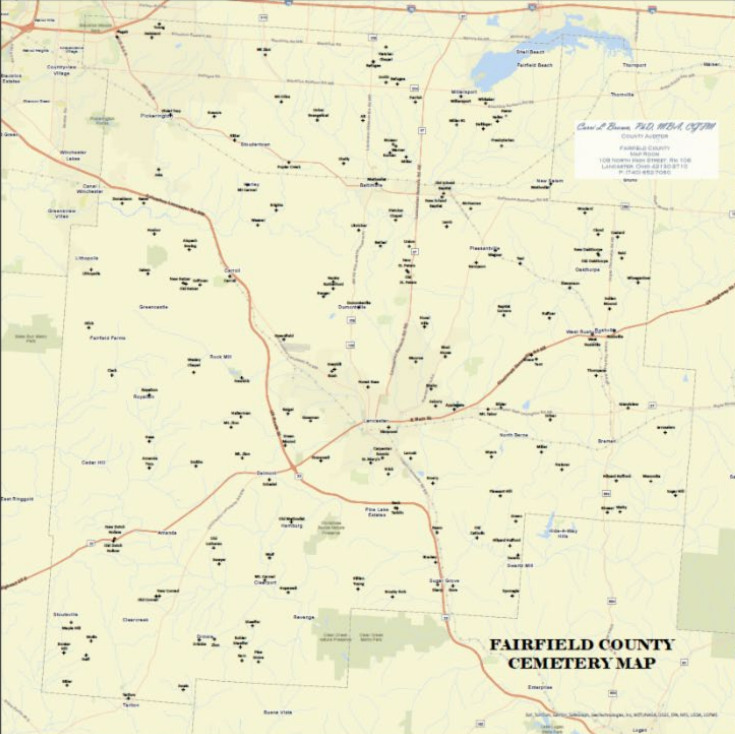

MEMORIAL DAY TRADITIONS

Memorial Day is an American holiday, observed on the last Monday of May, honoring the men and women who died while serving in the U.S. military.

Many Americans observe Memorial Day by visiting cemeteries and memorials. Some people wear a red poppy in remembrance of those fallen in war - a tradition that began with a World War I poem.

"In Flanders Fields" by John McCrae

*In Flanders fields the poppies blow
Between the crosses, row on row,
That mark our place; and in the sky
The larks, still bravely singing, fly
Scarce heard amid the guns below.*

*We are the Dead. Short days ago
We lived, felt dawn, saw sunset glow,
Loved and were loved, and now we lie
In Flanders fields.*

*Take up our quarrel with the foe:
To you from failing hands we throw
The torch; be yours to hold it high.
If ye break faith with us who die
We shall not sleep, though poppies grow
In Flanders fields.*

www.history.com

Volunteer Opportunity

"The purpose of the MIA Project is to locate, identify and inter the unclaimed cremated remains of American veterans through the joint efforts of private, state and federal organizations. To provide honor and respect to those who have served this country by securing a final resting place for these forgotten heroes."

Ohio has two National Cemeteries: Dayton & Ohio Western Reserve

Want to know more? Check out www.miap.us or contact Stephen Ciak at 614-571-8070

Juvenile Court Unveils Mural

Imagine a mural that brings to life the magic and excitement that is the Fairfield County Fair! Through an amazing partnership between Fairfield County Juvenile & Probate Court and local artist Bobbi McKinnon, we were able to do just that!

Over the course of several months, Bobbi patiently worked with a few youth who collaboratively painted a mural of our beloved Fairfield County Fair. Juvenile Court was fortunate enough to be able to unveil this beautiful piece with some of the talented young artists on April 16 and publicly showcase their great work in one of the Annex locations.



The mural depicts a towering Ferris wheel, its brightly colored gondolas spinning against a backdrop of Mount Pleasant. The artists imagined the wondrous aromas of fair fries, hotdogs, elephant ears, and of course, the mouth-watering Jimmy Jawbreakers booth as you walk the colorful leaf-covered fairgrounds. Through their art, they depicted the sound of families and friends laughing with one another as they ride the carousels or play carnival games, and the beautiful sounds of musical performances echo throughout the grounds.

Throughout the mural, there are nods to the community's unique identity and history. As it was said in the unveiling of this mural, "Fairfield County is OUR home."

"What was so priceless about the process of painting this mural, was watching how the youth and Bobbi supported one another the entire way. Youth encouraging youth who felt unartistic to participate

and watching as youth came back week after week more excited each time as the mural and their work came to life was inspirational. This mural not only showcases the beauty that is the Fairfield County Fair, but is a physical representation of the power, beauty, and resiliency that can be found in community.” - Juvenile Court Diversion Team.

Auditor Brown Participates in Grant Writing Seminar



Dr. Brown presented at the OU-L Grant Writing 101 Seminar on April 24th. The event was attended by roughly 100 individuals who learned how to write a successful grant from start to finish. Dr. Brown was joined by Gretchen Gregory, Grant Writer Survivor Advocacy Outreach Program/New Lead Enterprises, and Amy Eymann, CEO of the Fairfield County Foundation.

Save the Date - Real Estate Summit - Serving Those Who Have Served

Back by popular demand! Mark your calendars! We will be hosting a Real Estate Summit on Thursday, September 26, 2024 at the Fairfield Center in Pickerington. This event is geared towards those in the community who serve veterans. Topics include benefits and Ohio's Homestead Program; the VA loan process; conveyance of property procedures; the mass appraisal process and Auditor's real estate assessment webpages; and housing options for Veterans in Fairfield County.

This event is free and counts as 2.5 hours of continuing education for real estate and professional licensing.



Thank you!

As part of the Celebrate Women Conference, attendees brought toiletries to donate to the Ronald McDonald House. Thank you to everyone who donated!

And let's take another opportunity to congratulate Dr. Brown, on receiving the Jane Johnsen Vision for Women Award!

FROM THE CELEBRATE WOMEN COMMITTEE:
THANK YOU for your generous donations to the
Ronald McDonald House for the 2024 service project!
We asked and you answered the call!
We organized and delivered!
Thanks, Young Helper Sarah!



**CELEBRATE
WOMEN**



CONGRATULATIONS to DR. CARRI BROWN, AUDITOR
2024 JANE JOHNSEN VISION FOR WOMEN AWARD RECIPIENT

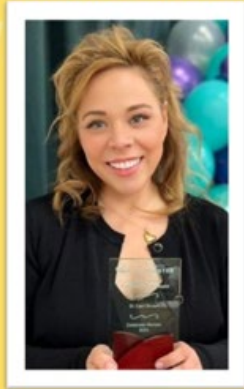

Getting to Know Our Team

Wherever You (Lo)Go

Our latest initiative is to have team members take photos while they are at various meetings or on vacations. Jess and her family took the Logo to Florida this past month!



Our Office Family is Expanding!



Amanda, our Settlements and Administration Analyst, will be welcoming a little one this summer! We enjoyed celebrating her and the baby at a surprise baby shower!

Getting to Know Michelle Wright

How we know she knows what she's doing:

- Degree: BA in Applied Business Management
- Certificates: Notary Public, Life and Health Insurance Agent
- Previous employment/experience: 10 yrs at Fairfield County Board of Developmental Disabilities as the Fiscal Officer; 3 yrs at Fairfield Medical Center as Compliance Coordinator; 17 years in corporate banking management



What does it mean to you to “Serve.Connect.Protect?”

To “Serve.Connect.Protect” means there is an understanding of how your actions create a ripple, which creates another ripple, and eventually a multitude of ripples. Therefore, each action must be performed with integrity and in mindful awareness that the outcome is going to reach far beyond the immediate impact you see.

Why do you choose to work at the Fairfield County Auditor’s Office?

After being a member of the implementation team to integrate changes for our data management system, I discovered how I completely enjoyed working with departments from all over the county. I enjoyed the network of collaboration and the positive changes it can provide. I loved being able to understand all perspectives of the financial process, and often joked I was the “bridge of knowledge” to support understanding between our centralized finance department and other county departments. This role soon evolved to a “need” and the job description seemed to fit me. With a little encouragement to leave my comfort zone at Fairfield County Board of Developmental Disabilities, I decided to jump on board with the Auditor’s team to help bring about positive changes and enhancements to our processes, and strengthen the relationships of all of those involved.

When she's not in the office, you can find her:

Hanging out in a barn tending to goats or cattle, attending a livestock show, supporting youth development through 4-H, conducting business matters of the Perry County Junior Fair Board, and in TRUE down time...hanging out with her friends and family while camping or on the lake!

Building Effective Communication

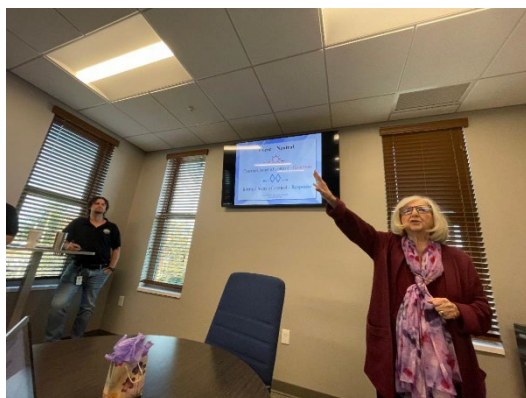

Our office frequently invites guest speakers to our all-staff meetings. In March we had the pleasure of welcoming Lillian Zarzar. Lillian led an in-service on communication mastery. Lillian is a public speaker, author, and coach with the Zarzar Group. It is always wonderful to hear from Lillian and our staff always comes away with terrific ideas for effective communication.

April Birthdays

19 - Angel



Resources



Follow Your Auditor's Office On
Social Media!

Did you know we have over 4,275 followers across our four social media platforms? If you're not one of those 4,275, you should join and follow!

- [LinkedIn](#)
- [Facebook](#)
- [Instagram](#)
- [Twitter](#)
- [YouTube](#)



Public Records Requests

The mode, median, and average response time for public records requests to the County Auditor's Office is within one day. If you have a request, please contact Rachel Elsea at rachel.elsea@fairfieldcountyohio.gov.

Frequently Used Forms

Most of the County Auditor forms can be found on our website. Special thanks go out to Angel Horn, Deputy Auditor, for updating our vendor forms.

[Search Forms](#)

May Dates of Interest

Military Awareness Month

5-11 - Public Service Recognition Week

15 – Peace Officer Memorial Day

27 – Memorial Day (County Offices Closed)

SAVE THE DATE

September 26 – Real Estate Summit –
Serving Those Who Have Served

Fairfield County Auditor's Office | [Website](#)



Fairfield County Auditor's Office | 108 North High Street, Lancaster, OH 43130

[Unsubscribe {recipient's email}](#)

[Update Profile](#) | [Constant Contact Data Notice](#)

Sent by rachel.elsea@fairfieldcountyohio.ccsend.com powered by



[Try email marketing for free today!](#)

REGULAR MEETING #18 - 2024
FAIRFIELD COUNTY COMMISSIONERS' OFFICE
MAY 07, 2024

AGENDA FOR TUESDAY, MAY 07, 2024

- 9:00 AM Review
- Regular Meeting
- Pledge of Allegiance
- Announcements
- Approval of Minutes for April 30, 2024
- Commissioners
- 2024-05.07.a A Resolution Authorizing the Approval of Proclamations [Commissioners]
- 2024-05.07.b A resolution approving to appropriate from unappropriated into a major expense category for Grant Fund# 3034, subfund#8350 for the FY2024 Ohio Airport Grant Program/Ohio Department of Transportation (ODOT), Grant match transfer from the General Fund # 1001 & Advance from the General fund. [Commissioners]
- 2024-05.07.c A resolution authorizing a fund to fund transfer for Fairfield County Job and Family Services (JFS) for the 2nd Quarter 2024 Allocation. [Commissioners]
- 2024-05.07.d A resolution authorizing the approval of repayment of advances to the General Fund from the CHIP PY2021 grants. [Commissioners]
- Fairfield County Engineer
- 2024-05.07.e A Resolution to Approve and Adopt the Fairfield County, Ohio, Road Design Manual, for Unincorporated Areas of Fairfield County, Ohio, Final Version Effective April 23, 2024 [Engineer]
- 2024-05.07.f A resolution to appropriate from unappropriated in a major expenditure object category County Engineer 2024-Motor Vehicle for general office supplies [Engineer]
- 2024-05.07.g A Resolution to Approve an Agreement between Fairfield County and Terracon Consultants, Inc. [Engineer]
- 2024-05.07.h A Resolution to Approve a Change Order for the FAI-CR7-1.94 Refugee Road Intersection Safety Improvement Project [Engineer]
- 2024-05.07.i A Resolution to Approve the Contract with Russell Standard Corporation for the 2024 Crack Sealing Project [Engineer]

- 2024-05.07.j A Resolution to Approve the Contract with Asphalt Materials, Inc. for the Purchase of Liquid Asphalt [Engineer]
- 2024-05.07.k A resolution to request for appropriations for additional unanticipated receipts of Memo receipts and memo expenses for fund 2050 for annual inspections in various subdivisions as of 04/29/2024. [Engineer]
- 2024-05.07.l A resolution to request for appropriations for additional unanticipated receipts of memo receipts and memo expenses for fund 3445 BLO-36 bridge replacement [Engineer]
- 2024-05.07.m A resolution to approve a reimbursement for REA/GIS services as a memo expenditure for fund 2024 – Motor Vehicle [Engineer]
- 2024-05.07.n A Resolution to Approve the Notice to Commence for the 2024 Crack Sealing Project [Engineer]
- 2024-05.07.o A Resolution to Approve the Notice to Commence for the Purchase of Liquid Asphalt [Engineer]
- Fairfield County Job and Family Services
- 2024-05.07.p A resolution to approve a memo exp./ memo receipt for the costs of Birth Certificates paid to Fairfield County Health Departments as a memo expenditure for fund# 2072 Public Children’s Services [JFS]
- 2024-05.07.q A Resolution Regarding a Purchase of Services Contract between TeenWorks and Job & Family Services [JFS]
- Fairfield County Regional Planning Commission
- 2024-05.07.r A Resolution to Approve an Award of Bid to Spires Paving Company for the CDBG PY2022 Village of Pleasantville Hickenlooper Street Improvement Project [Regional Planning Commission]
- Fairfield County Sheriff
- 2024-05.07.s A resolution to appropriate from unappropriated in a major expenditure object category for Sheriff’s Office Fund 2027, Weights. [Sheriff]
- 2024-05.07.t A resolution to appropriate from unappropriated in a major expenditure object category for Sheriff’s Office Fund 2394, Litter. [Sheriff]
- 2024-05.07.u A resolution to appropriate from unappropriated in a major expenditure object category for Sheriff’s Office Fund 2442, Commissary. [Sheriff]
- 2024-05.07.v A Resolution Authorizing the Disposal of Vehicles by Internet Auction with Gov Deals, Inc. [Sheriff]
- Payment of Bills
- 2024-05.07.w A Resolution Authorizing the Approval of Payment of Invoices for Departments that Need Board of Commissioners’ Approval [Commissioners]

The next Regular Meeting is scheduled for May 14, 2024, 1:00 p.m., The Liberty Center, 951, Liberty Dr., Lancaster

Adjourn

MCJDC Annual Meeting of the Board of Trustees, MCJDC, 12:00 p.m.

MCJDC Joint Board of Commissioners' Meeting, MCJDC, 1:30 p.m.

Regular Meeting #17 - 2024
Fairfield County Commissioners' Office
April 30, 2024

Review Meeting

The Commissioners met at 7:00 p.m. at the Wagnalls Memorial Library, 150 E. Columbus St., Lithopolis. Commissioner Levacy called the meeting to order, and the following Commissioners were present: Jeff Fix, Steve Davis, and Dave Levacy. County employees present: County Administrator, Aundrea Cordle; Commissioners' Clerk, Rochelle Menningen; Communications & Information Coordinator, Bennett Niceswanger; Budget Director, Bart Hampson; Auditor, Dr. Carri Brown; Clerk of Courts, Branden Meyer; Facilities and EMA Director, Jon Kochis; IT Director, Dan Neeley; Economic and Workforce Development Director, Rick Szabrak; Utilities Director, Tony Vogel; Interim RPC Director, Holly Mattei; Utilities Deputy Director, Josh Anders; Deputy Auditor, Angel Horn; and JFS Deputy Director, Heather O'Keefe. Also in attendance: George Bennett, Betty Bennett, Dennis Kull, Debbie Gobel, Lisa Thomas, Carol Myers, Cheryl Berner, Dave Berner, Mike Clark, Cindy Clark, Loren Townsend, Patsy Townsend, Mary Cullison, George Cullison, Scott Barr, Dale Solt, Carolyn Solt, Barbara Andermatt, John Andermatt, Jim Cottrell, Beth Cottrell, Sherry Pymmer, Frank Martin, Barb Martin, Jeff Williamsen, Melissa Connor, Judy Zollinger, Becky Hoover, Sue Mazzarini, Alyson Cupp, Christine Evans, Randy Evans, Laura Steele, David Steele, Ellie Powell, Keith Powell, Jenny Powell, Sophie Powell, Nicklas Riegel, Ned Riegel, Joe Moody, Christa Moody, Cherly Kohler, Jerry Starner, Angela Horn, Rebekah Copeland, David Copeland, Dave Ward, Nancy Ward, Charlie Tooill, Amy Tooill, JoAnn Lohne, Sarah Blunden, Peggy Pedigo, Cecil Miller, Linda Werner, Brian Marianne, and Van Vooritz.

Welcome

Commissioner Levacy opened the meeting by welcoming everyone in attendance and thanked the Wagnalls Memorial Library Director, Deb Silvia, Board President, Jeff Cotner, and the library staff for their wonderful hospitality.

Wagnalls Memorial Library Executive Director, Deb Silvia

Ms. Silvia welcomed everyone to the Wagnalls Memorial Library and spoke about upcoming events to celebrate the library's centennial. She stated that event information would be available on the library's website and on their Facebook and Instagram social media pages.

Listen & Learn – Gay Fad

Jason and David Anney proprietors of Gay Fad Studios, a company with historical roots in Lancaster, Ohio, spoke about Lancaster as a "Glass Town." Jason Anney stated that he and David revived the Gay Fad Studios company in 2021, which was started by Fran Taylor in the late 1930's. Fran came from Detroit to start her business that employed mostly women and sourced glass from Anchor Hocking. Bill Butcher was the Art Director for Gay Fad studios for its entire 24 years in existence. The business struggled when its designs were stolen from another company. Gay Fad Studio's glassware was hand painted. The Anney's worked with Fran's daughter, Stephanie Taylor, to revive Gay Fad Studios and stated that they adhere to the same standards as the original company. The Anney's spend time with antique dealers across the U.S and found over 4000 original Gay Fad Studio pieces. Jason stated that a female CEO from that era that had a studio in New York should be celebrated. The current Gay Fad Studios has exclusive glassware, a wholesale program that offers retailers access, and custom glassware for non-profits and businesses to raise money. There will be a three day event, June 21-23, showcasing Gay Fad Studios and partnering with 35 businesses, 20 national vendors, and 2 special guests. The event will be called "Bottoms Up." There will be 50 activities, 30 classes, and 10 presentations at the three day event in Lancaster.

Regular Meeting #17 - 2024
Fairfield County Commissioners' Office
April 30, 2024

This will be a regional and national show/event. The plan is to grow the show and make it an annual event. Shag will be debuting glassware and has designed glassware specifically for the show. Jonathan Capps will give a glass-blowing demonstration. Stephanie Taylor is coming from California to see the thriving downtown Lancaster area and to participate in the event. The Anney's encouraged everyone to participate in the event and to share information about the event on social media.

Commissioner Davis stated he looks forward to the event.

Public Comments

Melissa Hoover Connor of Pleasantville elaborated on previously stated dangers and other concerns regarding large solar energy projects.

Scott Bar, a teacher at Ohio Christian University, spoke about Wendell Berry, a man who wrote about the invasion of industrial solar. Mr. Barr read a poem from Mr. Berry titled, "A Vision".

Laura Steele of Amanda spoke about the generational farming of the land which she and her family live, and about drainage on that land.

Ellie Powell spoke about the natural landscape of the home in which she resides and offered concerns for the impact of solar energy.

Jeff Williamsen of Greenfield Township spoke about the employment controversy surrounding industrial solar projects. He stated his concern that the number of full-time permanent jobs that would be provided by an industrial solar farm has been inflated.

Christine Evans spoke about a family vineyard in Amanda, and the dreams associated with this business. She also spoke about the livelihood and health of her family and neighbors and encouraged exclusionary zones

Beth Cottrill of Cedarville Road thanked the Commissioners for considering exclusionary zones for industrial solar. She spoke about the rights of property owners and the impact of solar projects on properties and communities.

David Steele of Amanda spoke about the effect of water drainage on farms and about the farm tile that could be crushed by an industrial solar project. He urged the Commissioners to pass exclusionary zones prohibiting industrial solar projects.

Connie Spillman of Carroll spoke about her concern that less farmland would mean less food.

Randy Evans of Amanda spoke about his family's vineyard/farm, and the home he just remodeled, that will be adversely affected by the possible solar project.

Ervin Dumm of Amanda is worried about the damage and runoff of water caused by industrial solar energy farms.

Patsy Townsend stated she does not want her area to be industrialized and asked for exclusionary zones.

Commissioner Levacy thanked everyone for coming and for being so polite.

Regular Meeting #17 - 2024
Fairfield County Commissioners' Office
April 30, 2024

County Administration Update

- *The County Administration Update was provided by County Administrator, Aundrea Cordle, unless otherwise noted.*

Week in Review

Highlights of Resolutions

Administrative Approvals

The review packet contains a list of administrative approvals.

Resolution Review

There are 23 resolutions on the agenda for the voting meeting.

Resolutions of note:

- A resolution to approve the 2024 Ohio Airport Grant Program contract between ODOT, the Fairfield County Airport Authority, and the Fairfield County Commissioners. This is for the obstruction removal of Election House Rd at the Fairfield County Airport. Our local grant match for this project is \$112,260.00, and the maximum grant amount from ODOT is \$366,700.00
- A resolution to approve change order #1 with Gutknecht Construction for the Workforce Engineering Lab. The change order extends the completion date since the space has been occupied, delaying the start of the project.
- A resolution to authorize the \$10,000.00 in funding from the Ohio Secretary of Stated awarded to the Board of Elections for Cybersecurity Technical Assistance.
- A resolution authorizing an agreement for the installation of LED lighting upgrades at the Job and Family Services Building and DDC Controls at Workforce Center with Ameresco.
- A resolution to approve IV-D contracts between JFS and the Sheriff's Office for service of process and security services and Domestic Relations Court for magistrate services.
- A resolution authorizing the approval of a lease agreement with OU for classroom space at the Fairfield Center.
- A resolution to approve a memo receipt and memo expenditure for CPS and the CPS levy fund as covered under "movements of cash by operation of law."
- A resolution approving the amending of the Fairfield County Building Department's Commercial Building Permit Application Requirements and the fee schedule.
- A resolution authorizing the approval of advances from the general fund to Major Crimes.
- A resolution to sign the agricultural easement for the Tooill Farm through the Clean Ohio Local Agricultural Easement Purchase Program at the closing which will be scheduled with the Ohio Department of Agriculture.

Regular Meeting #17 - 2024
Fairfield County Commissioners' Office
April 30, 2024

Mr. Szabrak stated that the Engineering Lab at the Workforce Center will be a wonderful gem to show off to the rest of the state and will help attract manufacturers and jobs. The construction of the lab will be done by the end of the year.

Ms. Mattei stated that building permits will be able to be submitted electronically, which will enhance communication with the builders.

Calendar Review/Invitations Received

- *The review of calendar items, invitations received, and correspondence received was provided by the Clerk to the Board of Commissioners, Rochelle Menningen, unless otherwise noted.*
 - Spring 2024 Pickerington Honors Art Exhibition, May 5, 2024, 2:00 p.m.-4:00 p.m., Pickerington-Violet Township Historical Museum, 15 E. Columbus St., Pickerington
 - Amanda-Clearcreek Local Schools' Electric School Bus Celebration, May 6, 2024, 9:00 a.m., 328 E. Main St., Amanda
 - Light Ohio Blue Ceremony, May 8, 2024, 5:30 p.m., The Tree Church, 721 N. Memorial Dr., Lancaster, RSVP by May 3, 2024
 - The Forest Rose School Class of 2024 Graduation, May 17, 2024, 1:00 p.m., Forest Rose School, 739 College Ave., Lancaster
 - Fairfield County ADAMH Annual Dinner and Fundraising Event, May 21, 2024, 6:00 p.m., Wigwam Event Center, 10190 Blacklick-Eastern Rd. NW, Pickerington
 - Fairfield County Farm Bureau Policy Development Meeting, May 30, 2024, 8:00 a.m., Fairfield County Fairgrounds, Ricketts Hall, 157 E. Fair Ave., Lancaster
 - Ohio Attorney General's Elder Abuse Commission Conference, "Dollars and Sense: Financial Exploitation of Older Adults", June 26, 2024, 9:00 a.m., Sharonville Convention Center, 11355 Chester Rd., Cincinnati
 - CCAO Summer Symposium 2024, August 21-23, 2024, Hocking Hills Lodge and Conference Center, 20020 OH-664, Logan

Correspondence Received

- Press Release, Fairfield County ADAMH, April 25, 2024, "Jones Loflin, Keynote Speaker for Fairfield ADAMH Dinner"
- Correspondence Regarding Industrial Solar Projects
- Press Release, Office of County Auditor, April 25, 2024, Auditor's Office Appreciative for 2023 Community's Choice Award for Top Employer – Place to Work"
- Memo, Dr. Carri Brown, April 25, 2024, Subjects: Three Types of Property Tax Reductions & Save the Date Reminders
- Fairfield County Auditor's Wins of the Week, April 25, 2024
- Hocking Township Trustees' Resolution 24-07, Adopted April 22, 2024
- Newsletter, Fairfield County E-News Update

Regular Meeting #17 - 2024
Fairfield County Commissioners' Office
April 30, 2024

Old Business

Commissioner Fix thanked the two deputies in attendance and spoke about attending a meeting for the model zoning project. The Commissioner was pleased and encouraged by the number of townships and villages in attendance.

New Business

Auditor Brown spoke about the May map of the month to honor Memorial Day and the county cemeteries. She also spoke about teaching a course at OU on grant writing and conducting a mentorship program with Fairfield Homes. She thanked departments for meeting internal deadlines for financial reporting.

Commissioner Levacy spoke about the significance of the Stonewall Cemetery.

Clerk Meyer stated his office is celebrating one year at the Fairfield Center and the recent start of providing driver exam services. He added that he also recently taught a course with the Ohio Judicial College on fingerprinting processes and the Ohio Supreme court recognized Fairfield County as one of the counties that does the process very efficiently.

Treasurer Bahnsen spoke about working with taxpayers on questions they may have and added that his office will be working on the second half of 2023 tax bills. He added that the Land Bank annual report was recently filed with the state.

Mr. Szabrak gave a shoutout to Carrie Stone, a career navigator, who helps students around the county find job opportunities. He also spoke about the Workforce Center's summer camps and stated they are free and offer a variety of workforce specializations. You can go to the county's website, under Economic Development, for information on the summer camps.

Mr. Hampson noted the American Rescue Plan report for the quarter was completed and had been submitted to the Treasury.

Regular (Voting) Meeting

The Commissioners continued to their voting portion of the meeting and the following Commissioners were present: Jeff Fix, Steve Davis, and Dave Levacy. County employees present: County Administrator, Aundrea Cordle; Commissioners' Clerk, Rochelle Menningen; Communications & Information Coordinator, Bennett Niceswanger; Budget Director, Bart Hampson; Auditor, Dr. Carri Brown; Clerk of Courts, Branden Meyer; Facilities and EMA Director, Jon Kochis; IT Director, Dan Neeley; Economic and Workforce Development Director, Rick Szabrak; Utilities Director, Tony Vogel; Interim RPC Director, Holly Mattei; Utilities Deputy Director, Josh Anders; Deputy Auditor, Angel Horn; and JFS Deputy Director, Heather O'Keefe. Also in attendance: George Bennett, Betty Bennett, Dennis Kull, Debbie Gobel, Lisa Thomas, Carol Myers, Cheryl Berner, Dave Berner, Mike Clark, Cindy Clark, Loren Townsend, Patsy Townsend, Mary Cullison, George Cullison, Scott Barr, Dale Solt, Carolyn Solt, Barbara Andermatt, John Andermatt, Jim Cottrell, Beth Cottrell, Sherry Pymmer, Frank Martin, Barb Martin, Jeff Williamsen, Melissa Connor, Judy Zollinger, Becky Hoover, Sue Mazzarini, Alyson Cupp, Christine Evans, Randy Evans, Laura Steele, David Steele, Ellie Powell, Keith Powell, Jenny Powell, Sophie Powell, Nicklas Riegel, Ned Riegel, Joe Moody, Christa Moody, Cherly Kohler, Jerry Starner, Angela Horn, Rebekah Copeland, David Copeland, Dave Ward, Nancy Ward, Charlie Tooill, Amy Tooill, JoAnn Lohne, Sarah Blunden, Peggy Pedigo, Cecil Miller, Linda Werner, Brian Marianne, and Van Vooritz.

**Regular Meeting #17 - 2024
Fairfield County Commissioners' Office
April 30, 2024**

Pledge of Allegiance

Commissioner Levacy asked everyone to rise as able and led the Pledge of Allegiance.

Announcements

There were no announcements.

Approval of Minutes for April 23, 2024

On the motion of Jeff Fix and the second of Steve Davis, the Board of Commissioners voted to approve the Minutes for the Tuesday, April 23, 2024, meeting.

Roll call vote of the motion resulted as follows:
Voting aye thereon: Jeff Fix, Steve Davis, and Dave Levacy

Approval of Resolutions from the Fairfield County Board of Commissioners

On the motion of Jeff Fix and the second of Steve Davis, the Board of Commissioners voted to approve the following resolutions from the Fairfield County Board of Commissioners:

- 2024-04.30.a Approval of Fiscal Year 2024 Ohio Airport Grant Program contract between the Ohio Department of Transportation (ODOT) and the Fairfield County Airport Authority & Fairfield County Commissioners
- 2024-04.30.b A Resolution for Approval of Change Order No. 1 to the Contract between Gutknecht Construction and the Fairfield County Commissioners
- 2024-04.30.c A Resolution to Approve a Memo Receipt and Expense for the Stop Loss Pool Sub Fund & the Self-Funded Healthcare Fund
- 2024-04.30.d A Resolution Approving an Account-to-Account Transfer in a Major Object Expense Category for the Safety & Security Budget, General Fund #1001

Roll call vote of the motion resulted as follows:
Voting aye thereon: Jeff Fix, Steve Davis, and Dave Levacy

Approval of a Resolution from the Fairfield County Board of Elections

On the motion of Jeff Fix and the second of Steve Davis, the Board of Commissioners voted to approve the following resolution from the Fairfield County Board of Elections:

- 2024-04.30.e A Resolution to Authorize Funding Made Available to the Fairfield County Board of Elections for a Grant for Cybersecurity Technical Assistance and Appropriate from Unappropriated

Roll call vote of the motion resulted as follows:
Voting aye thereon: Jeff Fix, Steve Davis, and Dave Levacy

**Regular Meeting #17 - 2024
Fairfield County Commissioners' Office
April 30, 2024**

Approval of Resolutions from the Fairfield County Engineer

On the motion of Jeff Fix and the second of Steve Davis, the Board of Commissioners voted to approve the following resolutions from the Fairfield County Engineer:

- 2024-04.30.f A Resolution to Approve the Contract Bid Award for the 2024 Crack Sealing Project [Engineer] 2024-04.30.g A Resolution to Approve the Contract Bid Award for the FAI-CR17/31 Resurfacing Project
- 2024-04.30.h A resolution to appropriate from unappropriated in a major expenditure object category County Engineer 2024-Motor Vehicle to engineering consulting services.
- 2024-04.30.i A resolution to appropriate from unappropriated in a major expenditure object category County Engineer 2024-Motor Vehicle for materials & supplies

Roll call vote of the motion resulted as follows:

Voting aye thereon: Jeff Fix, Steve Davis, and Dave Levacy

Approval of Resolutions from Fairfield County Facilities

On the motion of Jeff Fix and the second of Steve Davis, the Board of Commissioners voted to approve the following resolutions from Fairfield County Facilities:

- 2024-04.30.j A Resolution Authorizing an Agreement for the Installation of LED Lighting Upgrades at the Job and Family Services Building and DDC Controls at Workforce Center with Ameresco
- 2024-04.30.k A Resolution Authorizing the Approval of a Lease Agreement with Ohio University for classroom space at The Fairfield Center

Director Kochis stated there are over 1000 light fixtures in the government services center and this will provide huge cost savings.

Roll call vote of the motion resulted as follows:

Voting aye thereon: Jeff Fix, Steve Davis, and Dave Levacy

Approval of Resolutions from Fairfield County Job and Family Services

On the motion of Jeff Fix and the second of Steve Davis, the Board of Commissioners voted to approve the following resolutions from Fairfield County Job and Family Services:

- 2024-04.30.l A Resolution to Approve a Memo Receipt and Memo Expenditure for Fairfield County Job & Family Services' Children Services Fund and Protective Service Levy Fund, Respectively
- 2024-04.30.m A Resolution to Approve a Title IV-D Contract between Fairfield County Job & Family Services, Child Support Enforcement Agency, and Fairfield County Court of Common Pleas, Domestic Relations Division

**Regular Meeting #17 - 2024
Fairfield County Commissioners' Office
April 30, 2024**

- 2024-04.30.n A Resolution to Approve a Title IV-D Contract between Fairfield County Job & Family Services, Child Support Enforcement Agency, and the Fairfield County Sheriff's Office
- 2024-04.30.o A Resolution to Approve a Title IV-D Contract between Fairfield County Job & Family Services, Child Support Enforcement Agency, and Fairfield County Sheriff's Office
- 2024-04.30.p A Resolution Approving an Account-to-Account Transfer into a Major Expenditure Object Category – Fund # 2072, Public Children Services

Roll call vote of the motion resulted as follows:

Voting aye thereon: Jeff Fix, Steve Davis, and Dave Levacy

Approval of Resolutions from the Fairfield County Regional Planning Commission

On the motion of Jeff Fix and the second of Steve Davis, the Board of Commissioners voted to approve the following resolutions from the Fairfield County Regional Planning Commission:

- 2024-04.30.q A Resolution to approve an amendment to the Commercial Building Permit Application Requirements and Fee Schedule for the Fairfield County Building Department
- 2024-04.30.r A Resolution Authorizing the Notice to Proceed and Notice of Commencement to Enviro Construction Co. for a CDBG Program Year 2022 Project for the Village of Pleasantville, Columbus/Pearl Street Sewer Improvements

Roll call vote of the motion resulted as follows:

Voting aye thereon: Jeff Fix, Steve Davis, and Dave Levacy

Approval of a Resolution from the Fairfield County Sheriff

On the motion of Jeff Fix and the second of Steve Davis, the Board of Commissioners voted to approve the following resolution from the Fairfield County Sheriff:

- 2024-04.30.s A Resolution Approving an Account-to-Account Transfer into a Major Expenditure Object Category – Fund 2593, Concealed Handgun License

Roll call vote of the motion resulted as follows:

Voting aye thereon: Jeff Fix, Steve Davis, and Dave Levacy

Approval of Resolutions from South Central Major Crimes Unit

On the motion of Jeff Fix and the second of Steve Davis, the Board of Commissioners voted to approve the following resolutions from South Central Major Crimes Unit:

- 2024-04.30.t A Resolution Authorizing the Approval of Advances from the General Fund to Fund #7829 JAG, #7830 DLEF, and #7858 COAP OCJS
- 2024-04.30.u A Resolution to Appropriate from Unappropriated in the 2024 JAG Grant Fund #78782924

Regular Meeting #17 - 2024
Fairfield County Commissioners' Office
April 30, 2024

Roll call vote of the motion resulted as follows:
Voting aye thereon: Jeff Fix, Steve Davis, and Dave Levacy

Approval of a Resolution from the Fairfield County Soil and Water Conservation District

On the motion of Jeff Fix and the second of Steve Davis, the Board of Commissioners voted to approve the following resolution from the Fairfield County Soil and Water Conservation District:

2024-04.30.v A Resolution to Sign the Agricultural Easement for the Tooill Farm through the Clean Ohio Local Agricultural Easement Purchase Program at a Closing to be Scheduled with the Ohio Department of Agriculture

Roll call vote of the motion resulted as follows:
Voting aye thereon: Jeff Fix, Steve Davis, and Dave Levacy

Approval of the Payment of Bills

On the motion of Jeff Fix and the second of Steve Davis, the Board of Commissioners voted to approve the following resolution for the Payment of Bills:

2024-04.30.w A Resolution Authorizing the Approval of Payment of Invoices for Departments that Need Board of Commissioners' Approval

Roll call vote of the motion resulted as follows:
Voting aye thereon: Jeff Fix, Steve Davis, and Dave Levacy

Adjournment

Commissioner Fix thanked his colleagues for continuing with the evening meetings, which he thinks is a great way to include additional residents from the county.

Sherry Pymer asked about election system hacking.

Commissioner Fix recommended she contact the Board of Elections as the Commissioners do not administer elections.

With no further business, on the motion of Jeff Fix and the second of Steve Davis, the Board of Commissioners voted to adjourn at 8:20 p.m.

Roll call vote of the motion resulted as follows:
Voting aye thereon: Jeff Fix, Steve Davis, and Dave Levacy

The next Regular Meeting is scheduled for 9:00 a.m. on Tuesday, May 7, 2024, at 210 E. Main St., Lancaster, OH.

A Resolution Authorizing the Approval of Proclamations

WHEREAS, it is the pleasant responsibility of the Fairfield County Board of Commissioners to recognize people, organizations, and occasions; and

WHEREAS, the Commissioners have reviewed and approved the attached proclamations.

NOW THEREFORE, BE IT RESOLVED, BY THE BOARD OF COUNTY COMMISSIONERS, FAIRFIELD COUNTY, STATE OF OHIO:

Section 1. That the Board of Commissioners approves the attached Proclamations of Recognition.

Prepared by: Rochelle Menningen

Fairfield County Board of Commissioners

A Proclamation Recognizing May as Foster Care & Adoption Recognition & Recruitment Month

WHEREAS, it is the pleasant responsibility of the Fairfield County Board of Commissioners to recognize people, organizations, and occasions of outstanding achievement and significance; and

WHEREAS, the Children's Bureau has identified May as National Foster Care Month with the theme "Engaging Youth. Building Supports."; and

WHEREAS, there were 7,028 foster homes in Ohio at the end of February, 2024, with 26 of those homes licensed by Fairfield County Protective Services; and

WHEREAS, there are more than 390,000 youth in foster care across the United States, including 62 children in the custody of Fairfield County, with 105 more youths placed in kinship homes; and

WHEREAS, foster homes in Fairfield County allow for children to remain in their communities and connected to schools, services, and relatives.

NOW THEREFORE, the Fairfield County Board of Commissioners does hereby formally declare May to be:

Foster Care & Adoption Recognition & Recruitment Month!

Throughout Fairfield County, we urge all residents to recognize and thank foster parents, kinship care providers, and adoptive parents. ***Further, we want to hear from individuals who are interested in fostering or adopting a child. For more information, call 740.652.7887 and ask to speak with someone on the foster care team!***

IN WITNESS WHEREOF, we have hereunto subscribed our names and caused the seal of the County of Fairfield to be affixed to this Proclamation on the 7th Day of May in the Year of Our Lord, Two Thousand Twenty-Four.

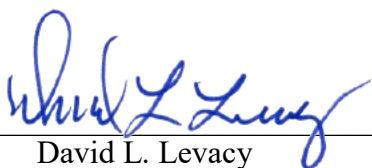
David L. Levacy
Commissioner

Jeffrey M. Fix
Commissioner

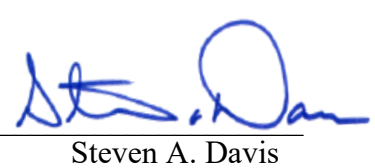
Steven A. Davis
Commissioner

Fairfield County Board of Commissioners

A Proclamation Recognizing May as Public Assistance Fraud Awareness Month

WHEREAS, It is the pleasant responsibility of the Fairfield County Board of Commissioners to recognize people, organizations, and occasions of significance; and

WHEREAS, Preventing and deterring public assistance fraud is a responsible effort, bringing awareness to how fraud costs all of us in the community; and

WHEREAS, In 2023 Job and Family Services received \$130,146 in fraud incentives, and investigated 684 fraud referrals with more than \$481,942 collected; and

WHEREAS, The collaboration of Job and Family Services and the County Prosecutor's Office led to the successful prosecution of 8 public assistance fraud cases resulting in \$155,367 in court ordered restitutions.

NOW THEREFORE, the Fairfield County Board of Commissioners does hereby formally declare May 2024 to be:

Public Assistance Fraud Awareness Month

Throughout Fairfield County, we urge residents to report suspected public assistance fraud by calling Fairfield County Job and Family Services at the Fraud Hotline: (740) 652-7616, or by reporting information at www.fcjfs.org. We recognize the exemplary collaborative efforts in investigating referrals and prosecuting cases. With this proclamation, we bring awareness to the fact that fraud in public assistance costs all of us in the community.

IN WITNESS WHEREOF, we have hereunto subscribed our names and caused the seal of the County of Fairfield, Ohio, to be affixed to this Proclamation on the 7th Day of May in the Year of Our Lord, Two Thousand Twenty-Four.

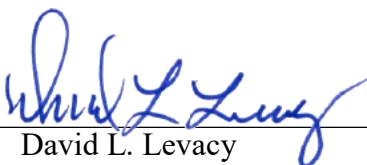

David L. Levacy
Commissioner



Jeffrey M. Fix
Commissioner

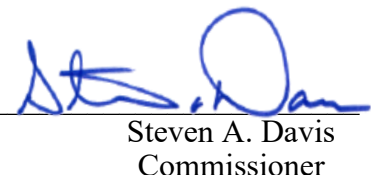

Steven A. Davis
Commissioner

Fairfield County Board of Commissioners

A Proclamation Recognizing May as Mental Health Month

WHEREAS, it is the pleasant responsibility of the Fairfield County Board of Commissioners to recognize people, organizations, and occasions of outstanding achievement and significance; and

WHEREAS, mental health is essential to everyone's overall health and well-being; and

WHEREAS, all Americans experience times of difficulty and stress in their lives as mental health conditions are real and prevalent in our nation; and

WHEREAS, prevention is an effective way to reduce the burden of mental health conditions; and

WHEREAS, with effective treatment and tools, individuals with mental health and other chronic health conditions can recover and lead full, productive lives; and

WHEREAS, each business, school, government agency, healthcare provider, organization and citizen shares the burden of mental health problems and has a responsibility to support prevention efforts and to promote mental wellness.

THEREFORE, the Fairfield County Commission does hereby proclaim:

May 2024 as Mental Health Month

The Fairfield County Board of Commissioners calls upon citizens, businesses, schools, and public and private institutions in Fairfield County to recommitting to increase awareness and understanding of mental health, protecting mental health, and providing appropriate and accessible services for all people with mental health conditions.

IN WITNESS WHEREOF, we have hereunto subscribed our names and caused the seal of the County of Fairfield to be affixed to this Proclamation on the 7th Day of May in the Year of Our Lord, Two Thousand Twenty-Four.

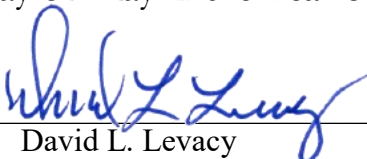

David L. Levacy
Commissioner



Jeffrey M. Fix
Commissioner



Steven A. Davis
Commissioner

Fairfield County Board of Commissioners

A Proclamation Recognizing May as Military Awareness Month

WHEREAS, it is the pleasant responsibility of the Fairfield County Board of Commissioners to recognize people and occasions of outstanding achievement and significance; and

WHEREAS, the freedom, security and preserved liberties that citizens of the United States enjoy today are direct results of the bloodshed and continued vigilance given by the United States Armed Forces and the sacrifices made by them and their family members that support them, over the history of our great nation; and

WHEREAS, the United States Congress, in two thousand and four, passed a resolution proclaiming May as National Military Appreciation Month, calling all Americans to remember those who gave their lives in defense of freedom and to honor the men and women of all of our Armed Services who have served and are now serving our Country, together with their families; and

WHEREAS, the month of May was selected for this display of patriotism because during this month, we celebrate Victory in Europe (VE) Day, Military Spouse Appreciation Day, Loyalty Day, Armed Forces Day/Week, and Memorial Day.

NOW THEREFORE, the Fairfield County Board of Commissioners does hereby formally declare May 2024 to be

Military Awareness Month

throughout Fairfield County and encourages all citizens to join the Board in showing our gratitude for past and present military personnel.

IN WITNESS WHEREOF, we have hereunto subscribed our names and caused the seal of the County of Fairfield, Ohio, to be affixed to this Proclamation on the 7th Day of May in the Year of Our Lord, Two Thousand and Twenty-Four.

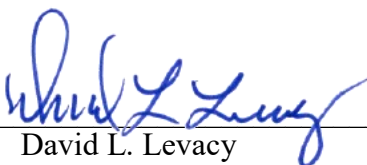

David L. Levacy
Commissioner



Jeffrey M. Fix
Commissioner



Steven A. Davis
Commissioner

Fairfield County Board of Commissioners

A Proclamation Recognizing May as Older Americans Month

WHEREAS, it is the pleasant responsibility of the Fairfield County Board of Commissioners to recognize people and occasions of outstanding achievement and significance;

WHEREAS, Meals on Wheels of Fairfield County includes a growing number of older Americans who enrich our community through their diverse life experiences and engagement with all generations; and

WHEREAS, Meals on Wheels of Fairfield County is committed to strengthening our community by connecting with and supporting older adults, their families, and caregivers, and acknowledging their many valuable contributions to society; and

WHEREAS, Meals on Wheels Older Adult Alternatives of Fairfield County can enhance the lives of older Americans in our community by:

- promoting home- and community-based services that support independent living;
- involving older adults in community events and other activities; and
- providing opportunities for older adults to work, volunteer, learn, lead, and mentor.

NOW THEREFORE, the Fairfield County Board of Commissioners, do hereby formally proclaim May 2024 to be:

Older Americans Month

We urge every resident to take time during this month to recognize older adults and the people who serve them as essential and valuable members of our community.

IN WITNESS WHEREOF, we have hereunto subscribed our names and caused the seal of the County of Fairfield, Ohio, to be affixed to this Proclamation on the 7th day of May in the Year of Our Lord, Two Thousand and Twenty-Four.

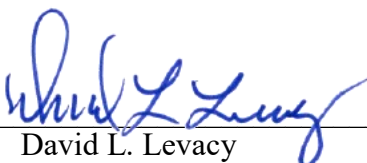

David L. Levacy
Commissioner



Jeffrey M. Fix
Commissioner



Steven A. Davis
Commissioner

Fairfield County Board of Commissioners

A Proclamation Recognizing Peace Officers' Memorial Day 2024

WHEREAS, it is the pleasant responsibility of the Fairfield County Board of Commissioners to recognize people and occasions of outstanding achievement and significance; and

WHEREAS, in 1962, President Kennedy proclaimed May 15 as National Peace Officers Memorial Day and the calendar week in which May 15 falls, as National Police Week. Established by a joint resolution of Congress in 1962, National Police Week pays special recognition to those law enforcement officers who have lost their lives in the line of duty for the safety and protection of others; and

WHEREAS, our public safety officers work tirelessly to protect our citizens, enforce our laws, and keep our neighborhoods safe; and

WHEREAS, every day, peace officers face the threat of violence and danger and they routinely put their lives on the line to defend ours, and the price of that bravery may result in injury, disability, or death; and

WHEREAS, the 2024 observance of Peace Officers' Memorial Day will help honor our law enforcement officers for their extraordinary service and sacrifice as we remember the fallen heroes whose selfless acts have left behind safer streets and stronger communities.

NOW THEREFORE, the Fairfield County Board of Commissioners, does hereby formally declare Monday, May 15, 2024 to be:

Peace Officers' Memorial Day 2024

We call upon everyone throughout Fairfield County to recognize the invaluable contributions of peace officers to uphold justice, enforce the rule of law, and protect the innocent.

IN WITNESS WHEREOF, we have hereunto subscribed our names and caused the seal of the County of Fairfield, Ohio, to be affixed to this Proclamation on the 7th Day of May in the Year of Our Lord, Two Thousand and Twenty-Four.

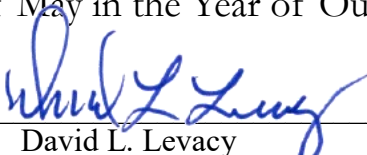
David L. Levacy
Commissioner

Jeffrey M. Fix
Commissioner

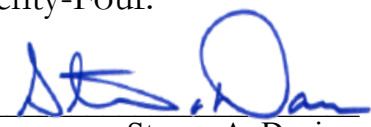
Steven A. Davis
Commissioner

Fairfield County Board of Commissioners

A Proclamation Recognizing May 19 – 25, 2024, as National Travel and Tourism Week

WHEREAS, it is the pleasant responsibility of the Fairfield County Board of Commissioners to recognize people, organizations, and occasions of outstanding achievement and significance; and

WHEREAS, the purpose of National Tourism Week is to celebrate the contributions and accomplishments of the U.S. travel community; and

WHEREAS, the annual tradition brings industry professionals together to highlight the value of travel and consider the broad impact it holds for communities across the country; and

WHEREAS, members of the community are coming together to support travel and tourism in Fairfield County;

NOW THEREFORE, the Fairfield County Board of Commissioners does hereby formally declare its respect for and recognition of:

May 19 – 25, 2024 as National Travel and Tourism Week

We call upon everyone in Fairfield County to observe this month with programs and activities that increase awareness and support travel and tourism in Fairfield County.

- Please visit www.visitfairfieldcounty.org for terrific information about travel and tourism in Fairfield County.
- Visit one of Fairfield County's beautiful parks, covered bridges, or museums.
- Invite a friend to enjoy a Fairfield County destination for good food and fun!

IN WITNESS WHEREOF, we have hereunto subscribed our names and caused the seal of the County of Fairfield to be affixed to this Proclamation on the 7th Day of May in the Year of Our Lord, Two Thousand Twenty-Four.

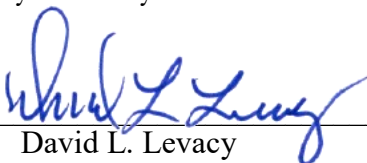

David L. Levacy
Commissioner



Jeffrey M. Fix
Commissioner



Steven A. Davis
Commissioner

Signature Page

Resolution No. 2024-05.07.a

A Resolution Authorizing the Approval of Proclamations

(Fairfield County Commissioners)

This resolution has not yet been voted on.

CERTIFICATE OF CLERK

It is hereby certified that the foregoing is a true and correct transcript of a resolution acted upon by the Board of County Commissioners, Fairfield County, Ohio on the date noted above.

A resolution approving to appropriate from Unappropriated into a major expense category for Grant Fund# 3034, subfund#8350 for the FY2024 Ohio Airport Grant Program/Ohio Department of Transportation (ODOT), Grant match transfer from the General Fund # 1001 & Advance from the General fund.

WHEREAS, the Board of Commissioners approved the grant agreement for the FY2024 Ohio Airport Grant Program funding of a maximum of \$366,700 per Resolution 2024-04.30.a; and

WHEREAS, estimated project costs are \$257,418.08, which includes a local match supported by the general fund in the amount of \$12,870.90; and

WHEREAS, it is necessary to establish 2024 budget figures: and

WHEREAS, appropriate from unappropriated into a major expenditure object category will allow the budget to be established; and

WHEREAS, a fund to fund transfer will transfer the local match monies; and

WHEREAS, an advance is necessary due to the grant being reimbursed after expenses occur.

NOW THEREFORE, BE IT RESOLVED BY THE BOARD OF COUNTY COMMISSIONERS, COUNTY OF FAIRFIELD, STATE OF OHIO:

Section 1. Request that the Board of County Commissioners approve to appropriate from unappropriated into a major expense category:

12303424 Capital Outlay \$ 257,418.08

Section 2. Request that the Board of County Commissioners approve the following fund to fund transfer:

\$ 12,870.90 12100148 700019 General Fund Match Transfers to
12303424 439100 Intergovernmental transfers in

Section 3. Request that the Fairfield County Auditor process the following advance with the repayment date of 12/15/2025.

DEBIT 1001 090000 General Fund Advance <\$200,000>
CREDIT 8350 223001 FY24 ODOT grant fund advance in +\$200,000
(Fund# 3034)

A resolution approving to appropriate from unappropriated into a major expense category for Grant Fund# 3034, subfund#8350 for the FY2024 Ohio Airport Grant Program/Ohio Department of Transportation (ODOT), Grant match transfer from the General Fund # 1001 & Advance from the General fund.

For Auditor's Purpose only:

Section 1.

\$ 257,418.08 12303424 570000 Capital outlay

Section 4. *Request that the County Auditor on behalf of the Budget commission to issue an amended certificate for fund # 3034, Subfund#8350 in the amount of \$257,418.08*

Section 4a. *Request that the County Auditor update the following revenue accounts:*

\$12,870.90 12303424 439100 Intergovt. Transfers in
\$244,547.18 12303424 433400 State Govt. revenue

Signature Page

Resolution No. 2024-05.07.b

A resolution approving to appropriate from unappropriated into a major expense category for Grant Fund# 3034, subfund#8350 for the FY2024 Ohio Airport Grant Program/Ohio Department of Transportation (ODOT), Grant match transfer from the General Fund # 1001 & Advance from the General fund.

(Fairfield County Commissioners)

This resolution has not yet been voted on.

CERTIFICATE OF CLERK

It is hereby certified that the foregoing is a true and correct transcript of a resolution acted upon by the Board of County Commissioners, Fairfield County, Ohio on the date noted above.

A resolution authorizing a fund to fund transfer for Fairfield County Job and Family Services (JFS) for the 2nd Quarter 2024 Allocation.

WHEREAS, the Board of Commissioners approved the 2024 Allocations for JFS to be disbursed in quarterly payments,

WHEREAS, it is necessary to transfer the cash to meet obligations.

NOW THEREFORE, BE IT RESOLVED BY THE BOARD OF COUNTY COMMISSIONERS, COUNTY OF FAIRFIELD, STATE OF OHIO:

Section 1. That the transfer of funds in the amount of \$97,069.50 hereby authorized as follows:

From: 12100149 700004 GRF mandated share Public Assist. transfers Out
To: 12201807 439100 Public Assistance Fund transfers in

Section 2. That the transfer of funds in the amount of \$442,549.50 hereby authorized as follows:

From: 12100149 700003 transfers out, CPS
To: 12207207 439100 Children Services Transfers in

Section 3. That the transfer of funds in the amount of \$58,233.75 hereby authorized as follows:

From: 12100149 700005 CSEA transfers out
To: 12201507 439100 CSEA transfers in

Prepared by: Staci Knisley
cc: Job & Family Services

Signature Page

Resolution No. 2024-05.07.c

A resolution authorizing a fund to fund transfer for Fairfield County Job and Family Services (JFS) for the 2nd Quarter 2024 Allocation.

(Fairfield County Commissioners)

This resolution has not yet been voted on.

CERTIFICATE OF CLERK

It is hereby certified that the foregoing is a true and correct transcript of a resolution acted upon by the Board of County Commissioners, Fairfield County, Ohio on the date noted above.

A resolution authorizing the approval of repayment of advances to the General Fund from the CHIP PY2021 grants.

WHEREAS, the FY21 CHIP grant activity is completed; and

WHEREAS, final draw requests were submitted and received; and

WHEREAS, the cash is available to repay the general fund.

NOW THEREFORE, BE IT RESOLVED BY THE BOARD OF COUNTY COMMISSIONERS, COUNTY OF FAIRFIELD, STATE OF OHIO:

Section 1. Request that the Fairfield County Auditor repay the following advances:

	Fund# 2732	
DEBIT:	8296 090001 CHIP/Ohio Housing Trust Fund advances out	<\$50,000>
CREDIT:	1001 223000 General Fund Advances In	+\$50,000

	Fund# 2731	
DEBIT:	8295 090001 CHIP/HOME advances out	<\$261,000>
CREDIT:	1001 223000 General Fund Advances In	+\$261,000

	Fund# 2730	
DEBIT:	8294 090001 CHIP/CDBG Fund advances out	<\$88,000>
CREDIT:	1001 223000 General Fund Advances In	+\$88,000

Prepared by: Staci Knisley, Commissioners Office
cc: Christina Foster

Signature Page

Resolution No. 2024-05.07.d

A resolution authorizing the approval of repayment of advances to the General Fund from the CHIP PY2021 grants.

(Fairfield County Commissioners)

This resolution has not yet been voted on.

CERTIFICATE OF CLERK

It is hereby certified that the foregoing is a true and correct transcript of a resolution acted upon by the Board of County Commissioners, Fairfield County, Ohio on the date noted above.

A Resolution to Approve and Adopt the Fairfield County, Ohio, Road Design Manual, for unincorporated areas of Fairfield County, Ohio, Final Version Effective June 7, 2024

WHEREAS, Fairfield County has a desire to inform and guide all users, potential users, developers, engineers, contractors, and others, in the planning, design, and construction of roadway infrastructures, in the unincorporated areas of Fairfield County; and

WHEREAS, the rules, guidelines, and standards set forth in the Fairfield County, Ohio, Road Design Manual, are applicable to work within all public right-of-way areas, subdivisions, and unincorporated areas of Fairfield County as defined by Chapter 711 of the Ohio Revised Code; and

WHEREAS, the Board of Fairfield County Board of Commissioners wishes to adopt guidelines and rules to assist potential users, developers, engineers, and contractors in infrastructure planning, design and construction.

NOW THEREFORE, BE IT RESOLVED BY THE BOARD OF COUNTY COMMISSIONERS, COUNTY OF FAIRFIELD, STATE OF OHIO:

Section 1. That the Fairfield County Board of Commissioners approves and adopts the Fairfield County, Ohio, Road Design Manual, for unincorporated areas of Fairfield County, Ohio, Final Version Effective June 7, 2024.

Prepared by: Rochelle Menningen



FAIRFIELD COUNTY, OHIO

ROADWAY DESIGN MANUAL

FOR UNINCORPORATED AREAS OF FAIRFIELD COUNTY, OHIO

Final Version-Effective **June 7, 2024**

Approved: May 7, 2024

Commissioners

Steve Davis
David Levacy
Jeff Fix

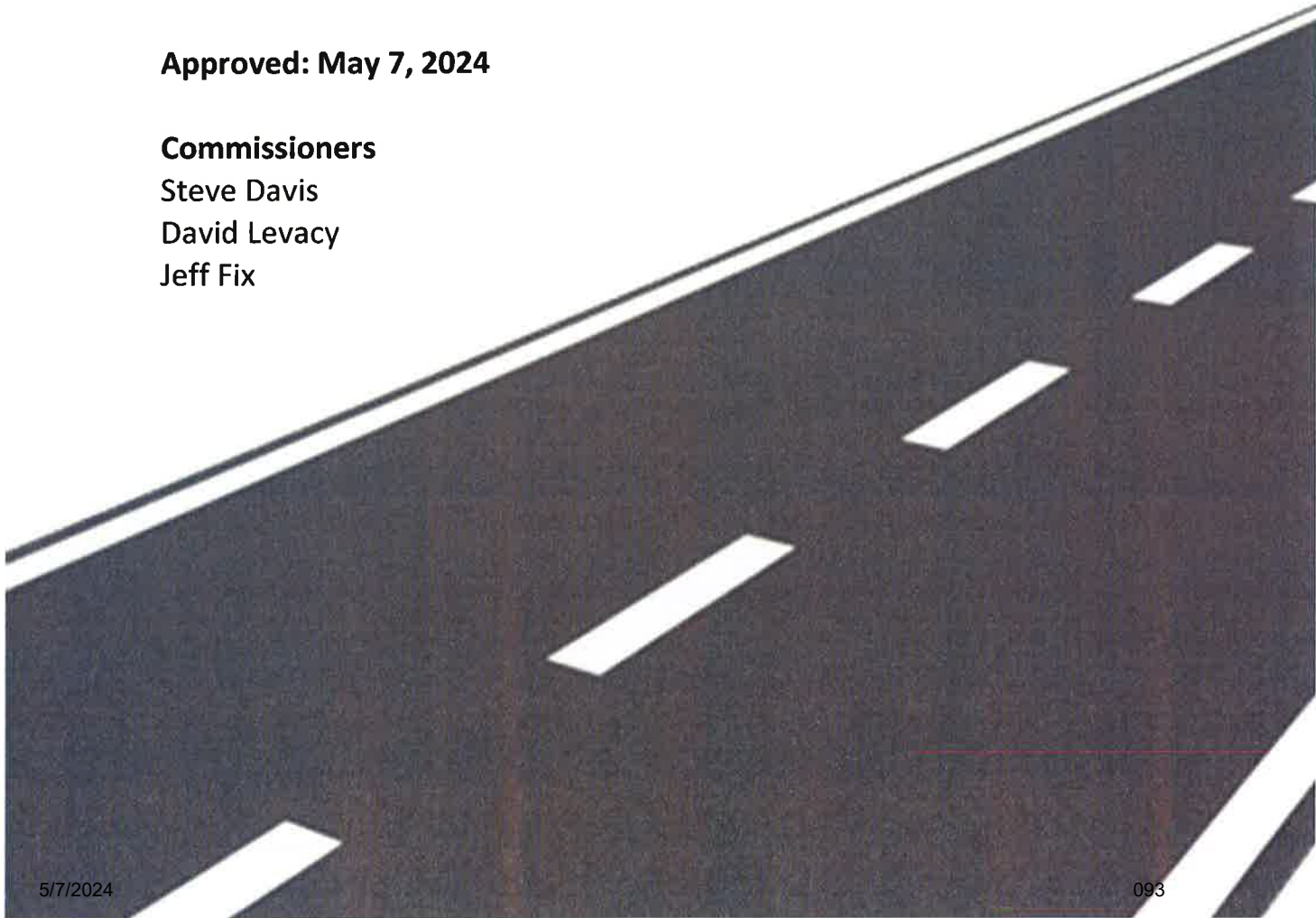

[This page intentionally left blank for double sided printing]

TABLE OF CONTENTS

1	General Considerations.....	1-1
1.1	Title.....	1-1
1.2	Purpose.....	1-1
1.3	Authority.....	1-1
1.4	Jurisdiction.....	1-1
1.5	Administration.....	1-1
1.6	Adoption.....	1-1
1.7	Amendment.....	1-1
1.8	Interpretation.....	1-2
1.9	Separability.....	1-2
1.10	Disclaimer.....	1-2
1.11	Construction Requirements.....	1-2
1.12	Design Exceptions.....	1-2
1.12.1	Design Exception Procedures.....	1-3
1.13	Roadway Naming Requirements.....	1-3
2	Roadway Design Standards.....	2-1
2.1	Purpose.....	2-1
2.2	Roadway Design.....	2-1
2.2.1	Right-of-Way Dedication Requirements.....	2-1
2.2.2	Roadway Design Criteria.....	2-2
2.2.2.1	Vertical Alignment.....	2-2
2.2.2.2	Horizontal Alignment.....	2-2
2.2.2.3	Pavement Width Requirements.....	2-2
2.2.2.4	Cross-Section Design.....	2-3
2.2.2.5	Medians and Boulevards.....	2-3
2.2.2.6	Curb and Gutter or Pavement Underdrains.....	2-3
2.2.2.7	Intersection Design Criteria.....	2-3
2.2.2.8	Pavement Composition.....	2-4
3	Access Management.....	3-1
3.1	Purpose.....	3-1
3.2	Public Road and Driveway Access onto a County or Township Road.....	3-1
4	Traffic Impact Study (TIS) Standards.....	4-1
4.1	Purpose.....	4-1
4.2	Requirement.....	4-1
4.3	Study Guidance.....	4-1
4.3.1	Pre-Study Meeting.....	4-2
4.3.2	Study Area.....	4-2
4.3.3	Design Year Traffic.....	4-2
4.3.4	Traffic Counts.....	4-2
4.3.5	Traffic Forecasts.....	4-3
4.3.6	Operational Analysis.....	4-4
4.3.7	ODOT Requirements.....	4-5
4.3.8	Memorandum of Understanding (MOU).....	4-5
5	Transportation Alternatives.....	5-1

5.1 Purpose.....	5-1
5.2 Planning and Design Manuals.....	5-1
6 Traffic Control Design Guidelines (Signage and Pavement Markings).....	6-1
6.1 Purpose.....	6-1
6.2 Street Signs.....	6-1
6.3 Traffic Control Devices and Pavement Markings.....	6-1
7 Traffic Signal Design Guidelines.....	7-1
7.1 Purpose.....	7-1
7.1.1 Signal Plans.....	7-1
7.1.2 Street Lighting.....	7-1

List of Tables

Table 1 – Existing County and Township Road Right-of-way Dedication

Table 2 – Subdivision Roadway Classification - Right-of-way Dedication and Road Width Requirements

Table 3 – Subdivision Roadway Classification – Alignment Requirement

Table 4A – Subdivision Roadway Classification – Asphalt Concrete Composition

Table 4B – Subdivision Roadway Classification – Concrete Base with Asphalt Surface Composition

Table 4C – Subdivision Roadway Classification – Concrete Pavement Composition

Appendices

Appendix A – Roadway Standard Construction Drawings

Appendix B – Design Exception Request Form

References

City of Lancaster. Street and Grading Design Manual. September 2019.

City of Pickerington. Traffic Impact Study Requirements. June 2021.

Delaware Co., Ohio. Delaware Co. Engineer’s Design, Construction & Surveying Standards. January 2008.

Fairfield County, Ohio. Construction and Material Specifications. March 2022.

Fairfield County, Ohio. Stormwater Design Manual. August 2022.

Fairfield County, Ohio. Subdivision Regulations. September 2019.

Fairfield County, Ohio. Traffic Impact Study Requirements. January 2017.

Ohio Department of Transportation. Construction and Material Specifications. January 2023.

Ohio Department of Transportation. Location and Design Manual, Volume 1, Roadway Design. July 2023.

Ohio Department of Transportation. Survey and Mapping Specifications. January 2023.

U.S. Access Board. Public Right-of-Way Accessibility Guidelines. 2013.

1 GENERAL CONSIDERATIONS

1.1 TITLE

These rules, guidelines, and standards contained herein shall be known and may be cited and referred to as the “Fairfield County, Roadway Design Manual” and shall hereinafter be referred to as “this Manual”.

1.2 PURPOSE

The purpose of the rules, guidelines, and standards set forth in this Manual and adopted by the Fairfield County Board of Commissioners is to provide engineering standards governing the design and construction of roadway infrastructure in the unincorporated areas of Fairfield County.

1.3 AUTHORITY

The rules, guidelines, and standards set forth in this Manual are adopted by the Fairfield County Board of County Commissioners in accordance with and pursuant to the legal grant of authority of Chapter 711 of the Ohio Revised Code (ORC) 711.101, to establish standards for the design and construction of improvements shown on the plats and plans within their jurisdiction.

1.4 JURISDICTION

The rules, guidelines, and standards set forth in this Manual shall be applicable to work within all public right-of-way and subdivisions of land as defined by Chapter 711 of the ORC hereinafter within the unincorporated areas of Fairfield County.

1.5 ADMINISTRATION

The Fairfield County Engineer’s Office (FCEO) and its staff are herein delegated the authority on behalf of the Fairfield County Board of Commissioners to administer and enforce the provisions of this Manual, with technical assistance and support from the Fairfield County Regional Planning Commission (FCRPC).

1.6 ADOPTION

This Manual shall become effective after adoption by the Fairfield County Board of Commissioners in accordance with Chapter 711 of the ORC. All or any previous Fairfield County Roadway Design Manuals shall be deemed to be repealed upon the adoption of the standard contained herein.

1.7 AMENDMENT

This Manual may be amended in accordance with the same procedure as stated in Section 1.6 of this Manual. The County Engineer, with input and collaboration with the Regional Planning Commission, may put forth requests regarding amendments to the Fairfield County Board of Commissioners for their review and adoption in the manner prescribed under Ohio Revised Code 711.

1.8 INTERPRETATION

In their interpretation and application, the provisions of this Manual shall be held to be minimum requirements for the promotion of health, safety, and general welfare of the people of Fairfield County. As such, in the development process, the Fairfield County Engineer's Office shall be entitled to apply reasonable interpretation of this Manual as is necessary to give force and effect to the purpose and intent of this Manual.

It is not intended by this Manual to interfere with, or abrogate, or annul any easements, covenants, or other agreements between parties unless they violate this Manual. When two specific provisions of this Manual conflict, or a provision of this Manual conflicts with any other lawfully adopted rules, regulations, ordinances, or resolutions, the most restrictive, or that imposing the higher standards shall apply.

1.9 SEPARABILITY

The invalidation of any clause, sentence, paragraph, or section of this Manual by a court of competent jurisdiction shall not affect the validity of the remainder of this Manual either in whole or in part.

1.10 DISCLAIMER

Neither submission of a plan under provisions of this Manual nor compliance with the provisions of this Manual shall relieve any person from responsibility for damage to any person or property otherwise imposed by law and shall not impose any liability upon Fairfield County for damage to any person or property.

1.11 CONSTRUCTION REQUIREMENTS

The latest edition of the Ohio Department of Transportation (ODOT) Construction and Materials Specifications (CMS), ODOT Standard Construction Drawings (SCD), Fairfield County Engineer's Office Forms and Permits, and portions of The City of Columbus CMS and SCD's shall govern the construction of roadways described in this Manual.

1.12 DESIGN EXCEPTIONS

Accepted procedures and requirements related to roadway design within the unincorporated areas of Fairfield County are provided in this Manual and supplemented by reference materials identified herein. The County recognizes that there may be individual projects involving special or unusual design challenges and the County's standards, as expressed in this Manual, may not provide solutions to all design problems. The County Engineer may consider and grant design exceptions on a project-by-project basis. All design exceptions must have the written approval of the County Engineer and comply with Section 1.12.1 of this Manual. Intended design exceptions must be requested during the preliminary engineering phase. These design exception requests shall be submitted in writing and, if approved by the County Engineer, documented (showing approval date and assigned ID number) on the title sheet of the final construction drawings that contain roadway improvements. Any approved design exceptions are not to be considered as precedent for future projects. The County Engineer does not have the authority to grant variances to state or federal regulations.

1.12.1. Procedures for Design Exceptions:

- A. Developers/engineers requesting design exceptions from standards associated with this Manual shall utilize Appendix B – Design Exception Request Form. It is encouraged to discuss the design exception request with the FCEO early in the subdivision process or preliminary design process.
- B. If the developer/engineer design exception(s) request is denied, the applicant may appeal to the Fairfield County Regional Planning Commission.

1.13 ROADWAY NAMING REQUIREMENTS:

The name of new roadways shall not duplicate existing roadway names, except where a roadway is extended, or when the new right-of-way is in alignment with an existing one. All new roads shall be named in accordance with the following requirements:

<u>General Direction</u>	<u>Designation</u>
<u>North and South</u>	<u>Avenue, Strip, or Way</u>
<u>East and West</u>	<u>Street or Trail</u>
<u>Curving</u>	<u>Drive</u>
<u>Dead End, North and South</u>	<u>Lane or Court</u>
<u>Dead End, East or West</u>	<u>Place or Terrace</u>
<u>Circular</u>	<u>Circle or Loop</u>
<u>Circular Divided Pavement, Any Direction</u>	<u>Boulevard, or Parkway</u>

2 ROADWAY DESIGN STANDARDS

2.1 PURPOSE

These Standards shall be used as minimum standards for designing all roadways/streets being approved through the major subdivision process plus for all roadways under jurisdiction of the County Engineer. These standards shall not be reduced without written approval (Design Exception) of the County Engineer. The arrangement of roadways/streets shall provide for the appropriate extension of existing streets and connectivity for future growth. The Fairfield County Engineer shall make the final determination as to the classification of any new roadway/street based on potential development of the site (existing and future ADT), the character of the surrounding area, and the thoroughfare plan.

2.2 ROADWAY DESIGN

2.2.1. Right-Of-Way Dedication Requirements

A. Existing Roadway Classification

1. The currently adopted Fairfield County Thoroughfare Plan shall be utilized to determine the appropriate ROW dedication or half-width dedication on existing roadways. See **Table 1**.

B. Proposed Roadway Classification

1. New public roadways shall dedicate right-of-way according to **Table 2**. Additionally, please find the requirements below for establishing the ADT of the proposed roadway.

Requirements for establishing ADT:

Average daily traffic (ADT) on residential streets shall be based on a calculation of ten (10) vehicle trips per dwelling unit plus other related factors such as schools, recreational facilities, and commercial facilities. This factor includes related residential-commercial trips.

The developer in determining the classification of their streets shall develop a traffic assignment network within his plat which realistically assigns trip data on the basis of least distance to plat exit. Trips for minor local and local streets will be assigned at point of connection to other streets.

In developing the traffic network, the developer shall assign additional trips for the following situations.

- A. Through Streets.
- B. Schools.
- C. Recreational Areas.
- D. Commercial Facilities.
- E. Terminals of streets to be continued in future subdivision activity.

The number of additional trips assigned due to the above factors will vary with the size and use of the facility involved.

If the terminals of any one street dedicates that a street shall be a certain classification, the total length of any such street shall be the same classification.

In the case where the traffic volumes indicate a street could be of one or two separate classifications, due to overlap of volumes within the classifications, the lesser classification shall be used when there is no influence on the traffic count by factors such as through streets, schools, recreational areas, etc.

The County Engineer shall consider the entrance street of subdivision a collector with respect to pavement width to the first intersection or a specified length as determined necessary. Left turn storage on all entrance streets shall be a minimum of 100 feet with a 50-foot divergent taper. Longer storage length shall be as established by an analysis. A minimum pavement width of 36 feet to accommodate turn lanes is required for all entrance streets (curbed and non-curbed). Curb and gutter shall be provided for all entrance street intersections with existing County, Township or State Highways, if the entrance street is curbed. The curb shall terminate at the end of the radius and taper to 0" in height at both curb ends. The minimum taper length is 10-feet. For non-curbed streets, a modified shoulder section shall be used.

2.2.2. Roadway Design Criteria

2.2.2.1 Vertical Alignment

A. Existing Roads:

Shall conform to the current version of the ODOT L&D manual. The current version of the AASHTO Geometric Design of Low-Volume Road may be used at the direction of the County Engineer.

B. Proposed Subdivision Roads:

Shall conform to **Table 3** contained within this manual.

2.2.2.2 Horizontal Alignment

A. Existing Roads:

Shall conform to the current version of the ODOT L&D manual. The current version of the AASHTO Geometric Design of Low-Volume Road may be used at the direction of the County Engineer.

B. Proposed Subdivision Roads:

Shall conform to **Table 3** contained within this manual.

- A 100-foot tangent shall be placed between reverse curves.
- Street jogs shall be discouraged. Where such jobs are unavoidable, in no case shall the centerline offsets be less than one hundred twenty-five (125) feet.

2.2.2.3 Pavement Width

A. Existing Roads:

Shall conform to the current version of the ODOT L&D manual. The current version of the AASHTO Geometric Design of Low-Volume Road may be used at the direction of the County Engineer.

B. Proposed Subdivision Roads:

Shall conform to **Table 2** contained within this manual.

2.2.2.4 Cross Section Design

A. Existing Roads:

Shall conform to the current version of the ODOT L&D manual. The current version of the AASHTO Geometric Design of Low-Volume Road may be used at the direction of the County Engineer.

B. Proposed Subdivision Roads:

Shall conform to the appropriate **Appendix A – Standard Drawing** located in this manual or as approved by the County Engineer.

2.2.2.5 Medians and Boulevards

A. Design of median width and/or boulevard shall be approved by the County Engineer on a case-by-case basis. The developer and/or engineer shall submit a preliminary design of the proposed median or boulevard for review and approval by the FCEO.

2.2.2.6 Curb and Gutter Underdrains or Pavement Underdrains

A. Underdrains shall outlet into structures for curb and gutter streets, and at the low point of the roadway profile for all open ditch streets. Precast reinforced concrete outlets are required for all Type F outlets. The pipe material for Type F outlets must comply with the current ODOT CMS.

2.2.2.7 Intersection Design Criteria

A. Existing Roads:

a. Shall conform to the current version of the ODOT L&D manual. The current version of the AASHTO Geometric Design of Low-Volume Road may be used at the direction of the County Engineer.

B. Proposed Subdivision Roads:

a. Horizontal Alignment at the Intersection: Streets should be laid out to intersect at ninety (90) degrees and no street shall intersect any other street at an angle of less than eighty-five (85) degrees. The horizontal approach tangent to an intersection shall be maintained for 100 feet from the edge of pavement of the intersecting street.

b. Vertical Alignment at the intersection: Roadways shall maintain a grade no greater than three percent (3%). The vertical alignment approach grade (3% or less) shall be maintained for 100 feet from the edge of pavement of the intersecting street. Intersection vertical alignments shall also be designed to comply with current ADA requirements.

c. Edge of Pavement Minimum Radius at Public Road Intersections:

i. Residential Development

1. 25-foot radius

ii. Industrial/Commercial Developments

1. Based on wheel tracking design of proposed trucks.

iii. Arterial Roadways (Major, Minor)

1. As required by the Fairfield County Engineer

2.2.2.8 Pavement Thickness

A. Existing Roads:

The Fairfield County Engineer shall determine the appropriate pavement build-up of existing roadways.

B. Proposed Subdivision Roads:

Shall be designed as per **Table 4A.**

3 ACCESS MANAGEMENT

3.1 PURPOSE

This section establishes procedures and standards to protect the utility, function, capacity, and safety of the roadway system located in Fairfield County. Unless otherwise specified in this Manual, refer to the current version of the ODOT State Highway Access Management Manual (SHAMM). Driveway access onto County Roadways shall follow permit guidelines and appropriate standard drawings and/or permit drawings. Additionally, driveways may also be required to follow the standards set forth in the current version of the ODOT Location and Design Manual, Volume 1, Roadway Design.

3.2 PUBLIC ROAD AND DRIVEWAY ACCESS ONTO A COUNTY ROAD OR TOWNSHIP ROAD

A. Public Road intersections

1. All new public road intersections shall meet intersection and stopping sight distance requirements per the ODOT L&D Manual.
2. See Section 4, Traffic Impact Study (TIS) standards for additional requirements when proposing to create another public road.
3. If access is made to a township road, the applicant/developer/engineer shall follow township rules/regulations. (Example: Violet Twp Access Management Plan).

B. Commercial and/or Industrial Driveways

1. The Developer/Property Owner shall apply for a driveway permit for access onto a County Roadway. The applicant shall comply with all permit approval guidelines and any FCEO standard drawings or permit drawings.
2. See Section 4, Traffic Impact Study (TIS) standards for additional requirements when proposing to access a county road with a commercial and/or industrial development.
3. If access is made to a township road, the applicant/developer/engineer shall follow township rules/regulations. (Example: Violet Twp Access Management Plan).

C. Residential Driveways

1. The Developer/Property Owner shall apply for a driveway permit for access onto a County Roadway. The applicant shall comply with all permit approval guidelines and any FCEO standard drawings or permit drawings.
2. If access is made to a township road, the applicant/developer/engineer shall follow township rules/regulations. (Example: Violet Twp Access Management Plan).

4 TRAFFIC IMPACT STUDY (TIS) STANDARDS

4.1 PURPOSE

The Fairfield County Engineer's Office's (FCEO) objectives for a Traffic Impact Study (TIS) are to:

- Determine the appropriate location, spacing, and design of the access connection(s) necessary to minimize traffic operational and safety impacts to the County roadway system according to the roadway function and in accordance with the standard and guidelines of ODOT, FHWA, Fairfield County and other appropriate standards and guidance.
- Determine the need for any improvements to the adjacent and nearby roadway system to maintain a satisfactory level of service and safety and to protect the function of the roadway system while providing appropriate and necessary access to the proposed development.
- Assure that the internal traffic circulation of the proposed development is designed to provide safe and efficient access to and from the adjacent and nearby roadway system consistent with County requirements.

4.2 REQUIREMENT

TIS reports are required to be prepared by the site developer in the following situations:

- Developments of any single type, or mixed-use types, that can be expected to generate more than 100 new peak hour vehicle trips on the adjacent street per ITE Trip Generation Manual (latest edition).
- Expansion of an Existing Development or a new Development of less than 100 new peak-hour trips in problem areas such as high crash locations, congested areas, or other areas of local concern to the County.
- Any change to the previously approved development plans or plats that will increase the site traffic generation by more than 15% if more than 100 peak-hour trips are involved will:
 - Void any previously approved TIS document.
 - Require submission and approval of a new TIS document.
- Any change to the directional distribution of traffic to change by more than 20% where the site traffic generation can be expected to ultimately be over 100 peak-hour trips.
- Any incomplete project/development when the original TIS is more than two (2) years old.
- Any of the following special circumstances would require a new TIS or updates to a previously approved TIS:
 - Any agreement between the developer and County that requires cost-sharing contributions to major roadway improvements.
 - Any other situations where the County Engineer believes it is important to understand the impact of traffic from the new development on the surrounding area.

4.3 STUDY GUIDANCE

A TIS submitted to the FCEO should generally follow the guidance in the Institute of Transportation Engineer's most recent version of *Transportation Impact Analysis for Site Development* and other generally accepted industry methodologies and procedures.

4.3.1. Pre-Study Meeting

Prior to the start of the TIS, a meeting is to be scheduled with the appropriate County staff and the TIS preparer. This meeting will establish the following issues and needs that the TIS will address:

- Study Area
- Opening and Design Year
- Field Data Collection
- Source of Background Traffic Growth Rates
- Analysis Required:
 - Capacity Analysis
 - Signal Warrant Analysis
 - Turn Lane Warrant Analysis
 - Intersection Safety Sight Distance Analysis
- Existing Safety Issues (high crashes, visibility concerns, etc.)

The TIS preparer shall submit a Memorandum of Understand (MOU) which details the assumptions and methodologies agreed upon at the pre-study meeting. The MOU should be submitted to the County within one week of the pre-study meeting.

4.3.2. Study Area

The Study Area for a TIS will be determined in cooperation with the Fairfield County Engineer's Office based on the size and potential impacts of the proposed change in land use. Typically, the study area will consist of:

- All intersections of proposed site driveways with county roadways
- At least one major¹ intersection on either side of the site
- Other intersections that could be significantly impacted by the traffic induced by the development (as determined by the FCEO)

The county retains the right to modify the minimum study area based on local or site-specific issues.

4.3.3. Design Year Traffic

The TIS is to analyze the opening year of the proposed development and the horizon year which is 10-years from the opening year. The County may require different horizon years based on the complexity and phasing of the proposed development. Acceptable methods for future traffic forecasting are outlined later in this document.

4.3.4. Traffic Counts

Traffic counts shall be performed using manual or automated collection devices that have been documented to produce accurate results.

¹ A "major intersection" is typically considered the next signalized intersection and/or the next roadway classified on the current version of the Fairfield County Thoroughfare plan as a Collector or higher classification.

All traffic counts must be taken on an average day (no holidays, inclement weather, special events, etc.) when nearby schools are in full session, unless otherwise directed by the FCEO.

24-hour counts to determine local peak hours are encouraged. These counts can be taken from other recent studies or MORPC's traffic count database. 24-hour counts should be less than 5 years old, and more recent if significant changes have occurred in growth and development in the study area since the count.

Intersection turning movement counts will be performed at all study intersections (that currently serve traffic) for the hours agreed to by the FCEO. Typical traffic count time and duration requirements are:

- Weekday morning peak period (2 hours)
- Weekday evening peak period (2 hours)
- If traffic within the study area is significantly influenced by a school, additional peak periods coinciding with the school peak hours may also be required.
- If the location is in an area that is primarily commercial, recreational, or of another use that generates significant Saturday traffic, Saturday peak period (2 hours typical) traffic volumes may also be required.
- If the site involves a church or is located near a large church, Sunday peak period (2 hours typical) may also be required.

Intersection turning movement counts should include separate accounting for heavy vehicles (B&C classifications as defined by ODOT). Cyclist and pedestrian movement volumes should also be collected in built-up areas or if specifically requested by the FCEO.

4.3.5. Traffic Forecasts

An appropriate background growth rate shall be applied to existing traffic volumes on study area roadways to estimate future traffic volumes on the roadways without the proposed development ("no-build" traffic volumes). The applicant is encouraged to request a growth rate from the Mid-Ohio Regional Planning Commission (MORPC), which is based on their regional travel demand model. If a MORPC generated rate is not available or inappropriate to use for other reasons, a rate can be developed from other data and proposed to the FCEO for use.

Additionally, any significant increase in vehicle trips due to other anticipated (approved or likely to occur) development in the study area shall be calculated using the current edition of and added to the background growth. The additional development to be included shall be agreed upon with the FCEO. If appropriate, a reduction in the background growth rate supplied by MORPC may be appropriate since some or all of the additional development may already be accounted for in the MORPC model.

Daily, peak hour of the adjacent street, and peak hour for the land use, trips for all development proposed by the applicant shall be calculated using the ITE *Trip Generation Manual*.

Estimates for Pass-by, Diverted Linked, and/or Internal Capture trips should be produced based on the procedures and information provided in the ITE *Trip Generation Manual, Volume 1: Users Guide and Handbook, NCHRP Report 684 – Enhancing Internal Trip Capture Estimation for Mixed-Use Developments*, or other applicable and defensible data and methods.

4.3.6. Operational Analysis

The analysis must include the design years of opening day of the full development and ten years after. Additional analysis years may be required if a phased approach is planned to implement the development.

All analyses shall examine the peak hour traffic volume for the adjacent roadway and the peak hour traffic volume of the proposed development. The analysis shall be prepared for the morning and afternoon (AM and PM) peak hours. School, Saturday, and/or Sunday peak hours should also be analyzed if appropriate. Land use classifications which experience high trip generations during periods outside of weekday street peak hours (schools, special events, recreational uses, etc.) shall require additional analyses of these off-peak hours.

The desirability of access locations shall be evaluated based on the requirements of the *Ohio Department of Transportation State Highway Access Management Manual* and other appropriate industry accepted access guidelines (*TRB Access Management Manual*). Intersection sight distance shall also be considered when locating new or modifying existing access locations and be in accordance with the latest version of ODOT L&D Manual Volume 1.

The TIS shall examine “before and after” conditions to evaluate traffic impacts associated with the proposed development. The impacts of all access alternatives on roadway capacity and throughput shall be calculated for the opening year Build and No-Build conditions and for the 10-year (from opening-day) Build and No-Build conditions. Analysis shall be performed using *Highway Capacity Software*, *Synchro*, or other software as agreed to and acceptable to the County, which calculates results based on the current version of the *Highway Capacity Manual*. Should the analysis indicate that the degradation below levels of service for either the opening day or design years for the build condition but not the no build conditions, then mitigation measures must be recommended to improve the levels of service to the desired threshold.

For all proposed access points or access modifications, an overall intersection level of service (LOS) of “C” shall be obtained for the 10-year analysis, with no single movement being worse than LOS E or having a volume to capacity ratio of more than 0.90. At adjacent, off-site, intersections and access points, the LOS calculated for each intersection approach in the proposed condition shall be the same or better than achieved by the existing intersections, with no individual movement being worsened by more than one LOS grade. For example, a left turn movement may not be degraded from a “C” to an “E.” Recommendations shall be made in the TIS for access points and external roadway improvements such as the addition/extension of turn lanes and through lanes as well as traffic control devices necessitated by the construction of the proposed development. The developer is responsible for mitigating the impacts of traffic generated by the project.

All improvements shall be constructed to provide adequate traffic queuing storage based on the ODOT Location and Design Manual, Vol. 1. Before and after traffic queuing lengths at each existing intersection shall also be calculated, tabulated, and compared to available storage lengths. Queuing storage deficiencies and improvements needed to correct these deficiencies shall be identified for opening year and 10-year conditions.

Existing and potential pedestrian and bicycle traffic flows shall be considered. If appropriate, a pedestrian and/or bicycle flow and access plan (sidewalks, paths, bike lanes roadway crossings, signal improvements, etc.) shall be included in the study.

Signal warrant analyses shall be conducted at all multi-movement access points considered in each alternative scheme. Any access which meets signal warrant thresholds but does not otherwise meet spacing requirements and standards as established for the roadway per the *State Highway Access Management Manual* may be required to be redesigned, reconstructed, and/or relocated. The study should evaluate the feasibility of coordinating any proposed signals with other existing signals within the study area to achieve desired traffic progression.

Left and right turn lane warrant analysis shall be conducted at each site access point. The turn lanes warrants shall be evaluated based on ODOT Location and Design Manual. If a turn lane is warranted, the length of the turn lane shall be calculated based on the criteria contained in ODOT Location and Design Manual, Volume 1, current version.

The study should recommend adoption of the access scheme which provides the safest design and most efficient level of service consistent with the purpose, requirements, and design standards of the *State Highway Access Management Manual*, the *ODOT Location and Design Manual*, and County requirements. The recommended access scheme should not aggravate an existing safety problem or create a potential new safety problem. All sight distances and other roadway geometry shall meet these established standards and guidelines.

4.3.7. ODOT Requirements

It should be noted that if ODOT review and approval of the traffic study is also required, the applicant should coordinate with ODOT District 5 to determine additional Traffic Impact Study requirements.

4.3.8. Memorandum of Understanding (MOU)

A MOU shall be prepared to define and clarify the above requirements in writing. The County shall approve the MOU prior to the completion and submission of the TIS. A typical MOU shall include the following:

- A preliminary site plan showing:
 - the proposed location, land use type, and size of all development components
 - the locations of all existing access points to the public roadway system
 - the proposed site's internal traffic circulation system (conceptual)
 - existing and proposed property lines and ownership
- Proposed Study Area with adjacent intersections identified will be included in the study
- Other development within the study area that is proposed, planned, in construction, or not yet completely occupied
- A table showing calculated Daily, Peak Hour of the Adjacent Street Traffic, and Peak Hour of the Generator trips for all development
- Proposed traffic count locations and times and justification
- Estimated daily and peak hour trips to be generated by each development component. Saturday and/or Sunday trips should be included if appropriate
- The assumed background growth rates (and the methodology for obtaining) for all existing roadways in the study area
- Assumed percentage distributions of generated traffic to the local roadway system.
- Assessment of the need for a pedestrian/bicycle flow plan
- Estimated schedule for construction and opening of development or phases of the development and the Design Year or Years of the study

5 TRANSPORTATION ALTERNATIVES

5.1 PURPOSE

This section serves as a source for planners and designers implementing pedestrian and bicycle facilities within Fairfield County right-of-way. Unless otherwise shown in this manual, planners and designers shall refer to the following manuals and design criteria:

5.2 PLANNING AND DESIGN MANUALS

- A. ODOT Multimodal Design Guide (MDG) both planning and design guidelines.
- B. U.S. Access Board Public Right-of-Way Accessibility Guidelines (PROWAG) design standards.

6 TRAFFIC CONTROL DESIGN GUIDELINES (SIGNING AND PAVEMENT MARKINGS)

6.1 PURPOSE

This section serves as a source for designers implementing traffic control devices within Fairfield County right-of-way.

6.2 STREET SIGNS

All necessary street name signs and locations are to be included in the Final Engineering and Construction Plan. These details shall be provided on the same plan sheet as the traffic control devices, pavement markings, etc. The street name signs are to be installed prior to opening any street to traffic, before approving the subdivision for maintenance by the Owner and releasing the subdivision for Building Permits. Written approval by the township trustees is required for all special street name signs before building permits will be issued. The standards for the street name signs shall be in accordance with the requirements of the County Engineer. All special street sign installations are to be maintained by the Owner or the property owners' (homeowners) association. All street name signs to be used shall be approved for use by the County Engineer and/or Township. Street signs (including bases) at the entrance to a subdivision from a County, Township, or State highway (within County or State right of way) shall be designed to current FHWA and ODOT standards.

6.3 TRAFFIC CONTROL DEVICES AND PAVEMENT MARKINGS

The Final Engineering and Construction Plan shall include all necessary traffic control signs, devices, and pavement markings, etc. These items shall be designed to meet the requirements of the current edition of the ODOT Manual of Uniform Traffic Control Devices (OMUTCD). These details shall be provided on a separate plan sheet in the Final Engineering and Construction Plan.

All pavement markings shall comply with these ODOT specifications for all roads. *Thermoplastic pavement markings shall be used on all roads.* Pavement markings for existing County/Township Road widenings must match the existing markings at the project limits.

The Owner is required to provide speed limit signs on existing County, Township or State Highways where the proposed subdivision entrance street(s) intersects the public highway. These signs shall state the posted speed limit for the intersecting County, Township, or State Highway.

Speed limit signs shall be placed on all subdivision streets. Spacing of signs shall comply with the ODOT MUTCD, current edition. School zone signs (e.g., pavement markings, cross walks. signs, etc.) shall be provided for all subdivision streets located within school zone limits as defined in the ODOT MUTCD. No parking signs shall be provided, if required based on street width.

A concrete right-in/right-out island (pork chop) shall be included with the Final Engineering, and if required, as part of the approved traffic study or preliminary plan. Details for the island shall be designed to deter illegal left-hand movements to the furthest extent possible. The final design of the pork chop will be on a case-by-case basis and final approval shall be issued through the FCEO.

These traffic control signs, devices and pavement markings shall be installed prior to approving the subdivision to maintenance by the Owner or releasing the subdivision for building permits.

7 TRAFFIC SIGNAL DESIGN GUIDELINES

7.1 PURPOSE

This section serves as a source for designers implementing traffic control signals, pedestrian signals, hybrid beacons, emergency-vehicle signals, traffic control signals for one-lane, two-way facilities, flashing beacons, lane-use control signals, and in-roadway lights within Fairfield County right-of-way.

7.1.1. Signal Plans

Traffic Signal plans shall be shown on separate plan sheet(s). Refer to the current version of the Ohio Manual of Uniform Traffic Control Devices (OMUTCD), Part 4.

7.1.2. Street Lighting

The County Engineer shall approve all street lighting details (e.g., poles, luminaries, conduit, etc.). These details shall be included in the Final Engineering and Construction Plan.

The appropriate Township shall be contacted to determine if street lighting is required and who will be responsible for future maintenance including energy cost.

Tables

Table 1 – Existing County and Township Road Right-of-way Dedication

Table 2 – Subdivision Roadway Classification - Right-of-way Dedication and Road Width Requirements

Table 3 – Subdivision Roadway Classification – Alignment Requirement

Table 4A – Subdivision Roadway Classification – Asphalt Concrete Composition

Table 4B – Subdivision Roadway Classification – Concrete Base with Asphalt Surface Composition

Table 4C – Subdivision Roadway Classification – Concrete Pavement Composition

TABLE 1
RIGHT-OF-WAY WIDTH DEDICATION
[REFERENCE: FCRPC - THOROUGHFARE PLAN]

TABLE 1 - EXISTING COUNTY AND TOWNSHIP ROAD RIGHT-OF-WAY DEDICATION

Functional Class	Right-of-way Dedication (ft)
Interstate/Expressway	Agency Requirements
Principal Arterial	150
Minor Arterial	120
Major Collector	100
Minor Collector	80
Local	60 Minimum*

* Public dedication shall follow ADT range found in Table 2, but in no case shall be less than 60 feet.

**TABLE 2 AND TABLE 3
SUBDIVISION ROAD - DESIGN CRITERIA**

TABLE 2 - SUBDIVISION ROADWAY CLASSIFICATION - ROW AND ROAD WIDTH REQUIREMENT

Subdivision Street Classification	ADT Range	Minimum Right-of-way Dedication (ft)		Minimum Pavement Width (ft)	
		With Curb and Gutter	Without Curb and Gutter	with Curb and Gutter	without Curb and Gutter
Major Arterial	>6000	100	100	27 & 27	24 & 24
Minor Arterial	3,000-5,999	80	80	51	48
Collector	1,500-2,999	60	72	36	28
Local	1-1,499	50	60	28	24
Commercial - Industrial	-	72	72	36	28
Alley	-	20	20	15	15

TABLE 3 - SUBDIVISION ROADWAY CLASSIFICATION - ALIGNMENT REQUIREMENT

Subdivision Street Classification	ADT Range	Maximum Grade (%)	Design Speed (mph)	Minimum Centerline Radius (feet)	Maximum Grade Break Without Curve (%)	Minimum K Value for Crest Vertical Curve	Minimum K Value for Sag Vertical Curve
Major Arterial	>6000	5	60	1275	0.3	207	123
Minor Arterial	3,000-5,999	5	55	955	0.4	152	103
Collector	1,500-2,999	7	45	600	0.55	79	69
Local	1-1,499	8	30	250	1.3	30	36
Commercial - Industrial	-	6	45	600	0.55	79	69
Alley	-	8	10	50	1.3	30	36

TABLE 4 (A,B,C)
SUBDIVISION ROADWAY - PAVEMENT COMPOSITION REQUIREMENTS

TABLE 4A - SUBDIVISION ROADWAY CLASSIFICATION - ASPHALT CONCRETE THICKNESS

Subdivision Street Classification	304 (in)	301 (in)	Intermediate Course (in)	Surface Course (in)
Major Arterial	6	8	1.75	1.25
Minor Arterial	6	7	1.75	1.25
Collector	6	6	1.75	1.25
Local	6	5	1.75	1.25
Commercial - Industrial	6	9	1.75	1.25
Alley	6	5	1.75	1.25

TABLE 4B* - SUBDIVISION ROADWAY CLASSIFICATION - CONCRETE BASE WITH ASPHALT SURFACE THICKNESS

Subdivision Street Classification	304 (in)	305 (in)	Intermediate Course (in)	Surface Course (in)
Major Arterial	4	7	1.75	1.25
Minor Arterial	4	7	1.75	1.25
Collector	4	7	1.75	1.25
Local	4	6	1.75	1.25
Commercial - Industrial	4	7	1.75	1.25
Alley	4	6	1.75	1.25

* Table 4B can be utilized with prior approval from the County Engineer and/or Township (if Twp Road).

TABLE 4C* - SUBDIVISION ROADWAY CLASSIFICATION - CONCRETE PAVEMENT THICKNESS

Subdivision Street Classification	304 (in)	452 (in)
Major Arterial	4	9
Minor Arterial	4	8
Collector	4	8
Local	4	7
Commercial - Industrial	4	9
Alley	4	7

* Table 4C can be utilized with prior approval from the County Engineer and/or Township (if Twp Road).

Appendices

Appendix A Roadway Standard Construction Drawings

- Exhibit R-1 24' Pavement Section; Local Street – 60' Right of Way
- Exhibit R-2 28' Pavement Section; Collector Street – 72' Right of Way
- Exhibit R-3 48' Pavement Section; Minor Arterial – 80' Right of Way
- Exhibit R-4 28' Pavement Section; Industrial Street – 72' Right of Way
- Exhibit R-5 28' Pavement Section with Curb and Gutter; Local Street – 50' Right of Way
- Exhibit R-6 36' Pavement Section with Curb and Gutter; Collector Street – 60' Right of Way
- Exhibit R-7 51' Pavement Section with Curb and Gutter; Minor Arterial – 80' Right of Way
- Exhibit R-8 27' & 27' Pavement Section with Curb and Gutter; Major Arterial – 100' Right of Way
- Exhibit R-9 36' Pavement Section with Curb and Gutter; Industrial Street – 72' Right of Way
- Exhibit R-10 Concrete Combined Curb and Gutter
- Exhibit R-11 Mountable Curb
- Exhibit R-12 Edge of Pavement Deep Strength Asphalt w/Underdrain
- Exhibit R-13 Edge of Pavement Deep Strength Asphalt w/Aggregate Drain
- Exhibit R-14 Typical Pavement Section
- Exhibit R-15 Backfill within ROW (influence line)
- Exhibit R-16 Roadway Termination

Appendix B Design Exception Request Form

APPENDIX A
ROADWAY STANDARD CONSTRUCTION DRAWINGS

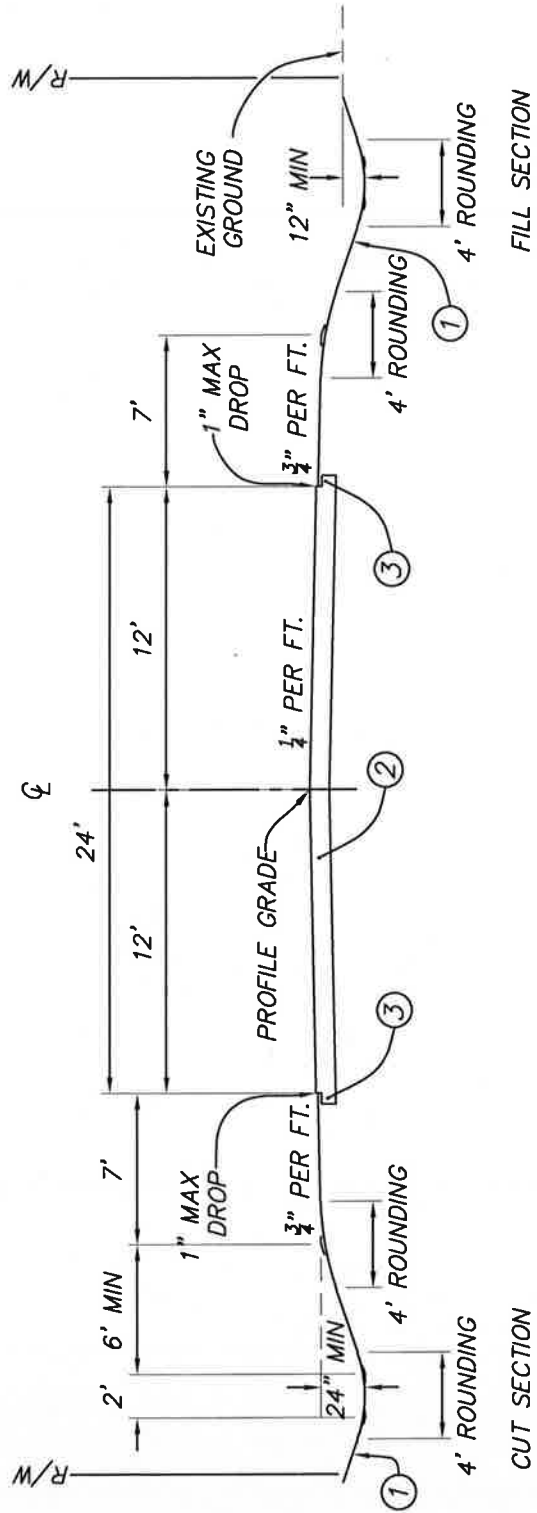

- ① CUT SECTION 5' AND UNDER - 3:1
CUT SECTION OVER 5' - 2½:1
FILL SECTION 5' AND OVER - 2½:1
FILL SECTION UNDER 5' - 4:1

② SEE "MINIMUM PAVEMENT COMPOSITION" TABLE FOR DESIGN THICKNESS - TABLE 4A AND EXHIBIT R-14

③ SEE EXHIBITS R-12 AND R-13

24' PAVEMENT SECTION
LOCAL STREET - 60' RIGHT OF WAY

EXHIBIT R-1
REV. 5-07-24

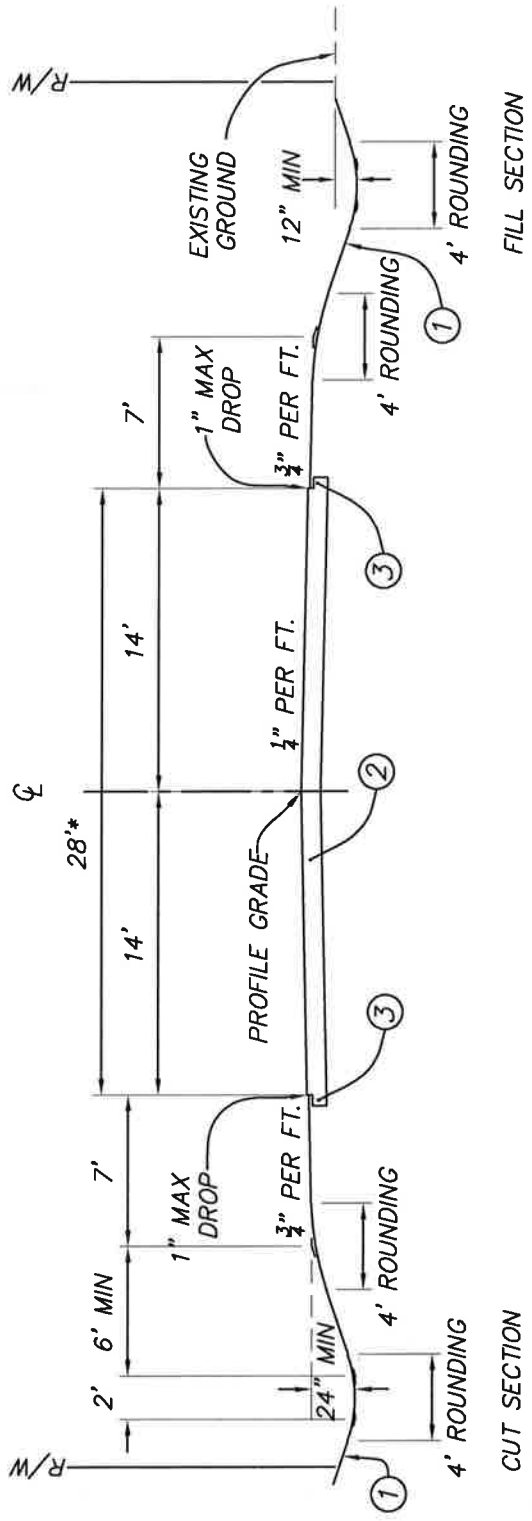

- ① CUT SECTION 5' AND UNDER - 3:1
CUT SECTION OVER 5' - 2½:1
FILL SECTION 5' AND OVER - 2½:1
FILL SECTION UNDER 5' - 4:1
- ② SEE "MINIMUM PAVEMENT COMPOSITION" TABLE FOR DESIGN THICKNESS - TABLE 4A AND EXHIBIT R-14
- ③ SEE EXHIBITS R-12 AND R-13

28' PAVEMENT SECTION
COLLECTOR STREET - 72' RIGHT OF WAY

EXHIBIT R-2
REV. 5-07-24

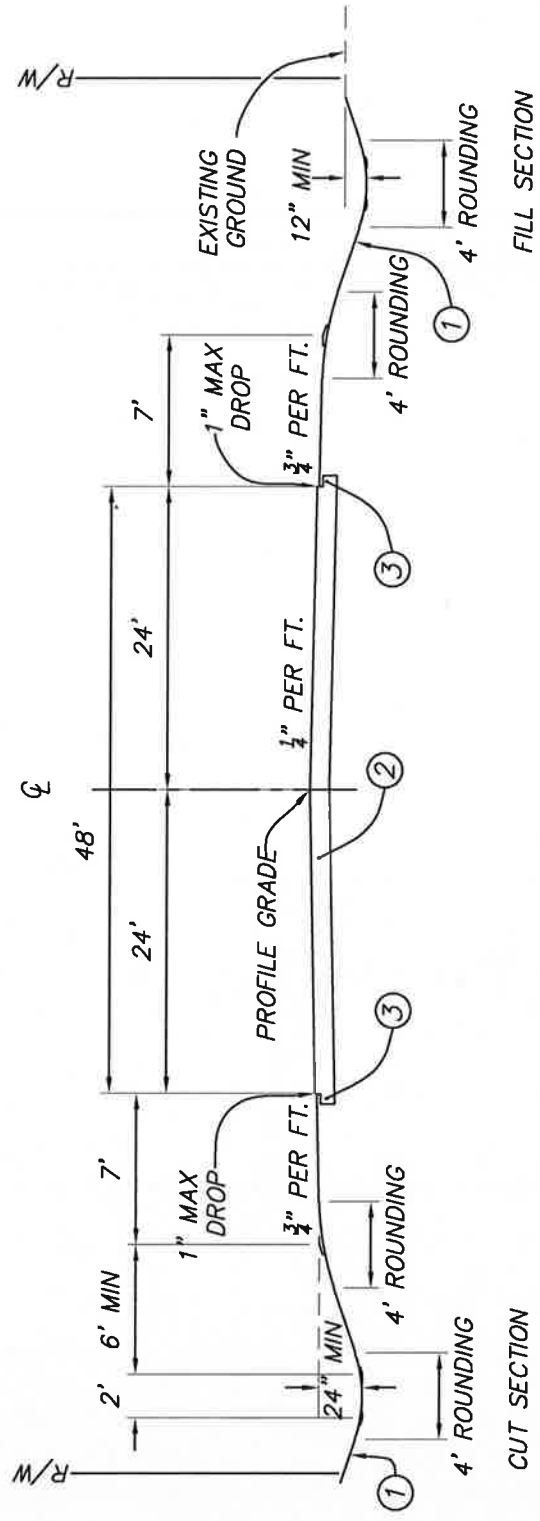

- ① CUT SECTION 5' AND UNDER - 3:1
 CUT SECTION OVER 5' - 2½:1
 FILL SECTION 5' AND OVER - 2½:1
 FILL SECTION UNDER 5' - 4:1

② SEE "MINIMUM PAVEMENT COMPOSITION" TABLE FOR DESIGN THICKNESS - TABLE 4A AND EXHIBIT R-14

③ SEE EXHIBITS R-12 AND R-13

48' PAVEMENT SECTION
 MINOR ARTERIAL - 80' RIGHT OF WAY

EXHIBIT R-3
 REV. 5-07-24

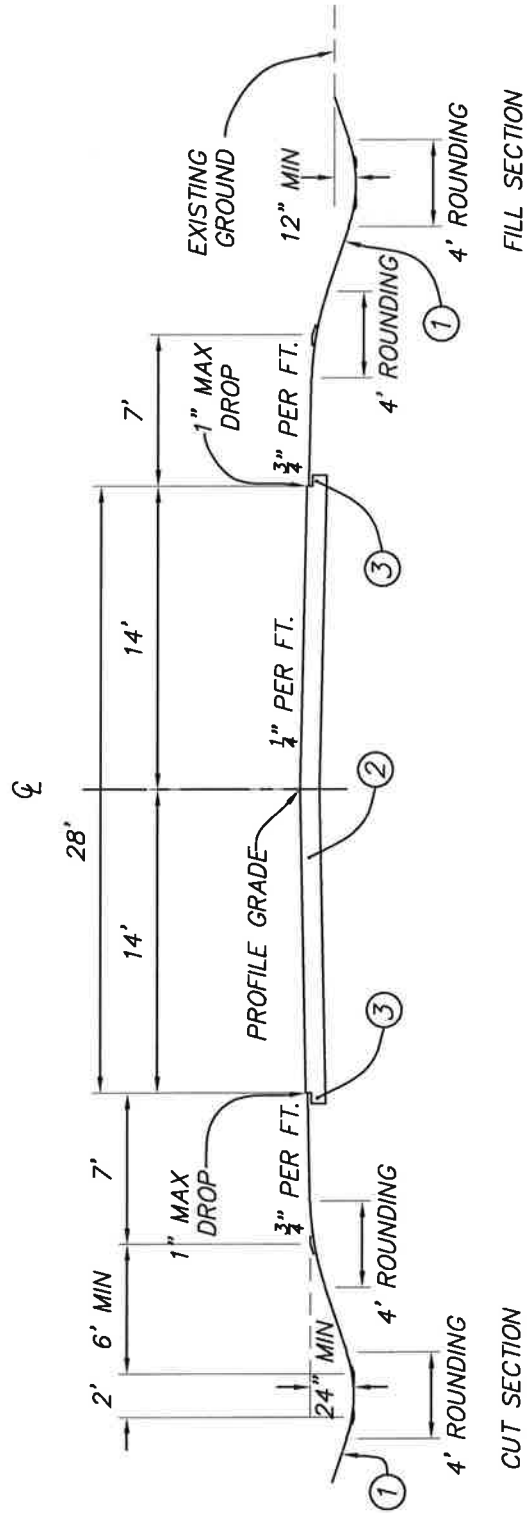

- ① CUT SECTION 5' AND UNDER - 3:1
CUT SECTION OVER 5' - 2½:1
FILL SECTION 5' AND OVER - 2½:1
FILL SECTION UNDER 5' - 4:1
- ② SEE "MINIMUM PAVEMENT COMPOSITION" TABLE FOR DESIGN THICKNESS - TABLE 4A AND EXHIBIT 4-14
- ③ SEE EXHIBITS R-12 AND R-13

28' PAVEMENT SECTION
INDUSTRIAL STREET - 72' RIGHT OF WAY

EXHIBIT R-4
REV. 5-07-24

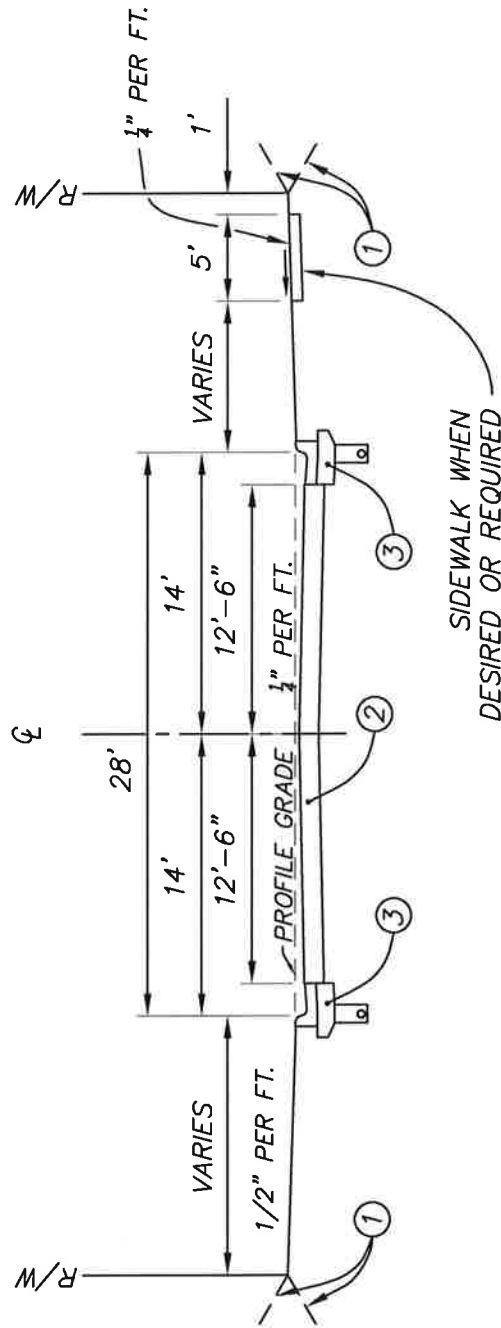

NOTE: STREET WIDTH BACK TO BACK OF CURB SHALL BE 29'.

- ① CUT SECTION 5' AND UNDER - 3:1
CUT SECTION OVER 5' - 2½:1
FILL SECTION 5' AND OVER - 2½:1
FILL SECTION UNDER 5' - 4:1
- ② SEE "MINIMUM PAVEMENT COMPOSITION" TABLE FOR DESIGN THICKNESS - TABLE 4A AND EXHIBIT R-14
- ③ SEE EXHIBITS R-10 AND R-11

28' PAVEMENT SECTION WITH CURB AND GUTTER
LOCAL STREET - 50' RIGHT OF WAY

EXHIBIT R-5
REV. 5-07-24

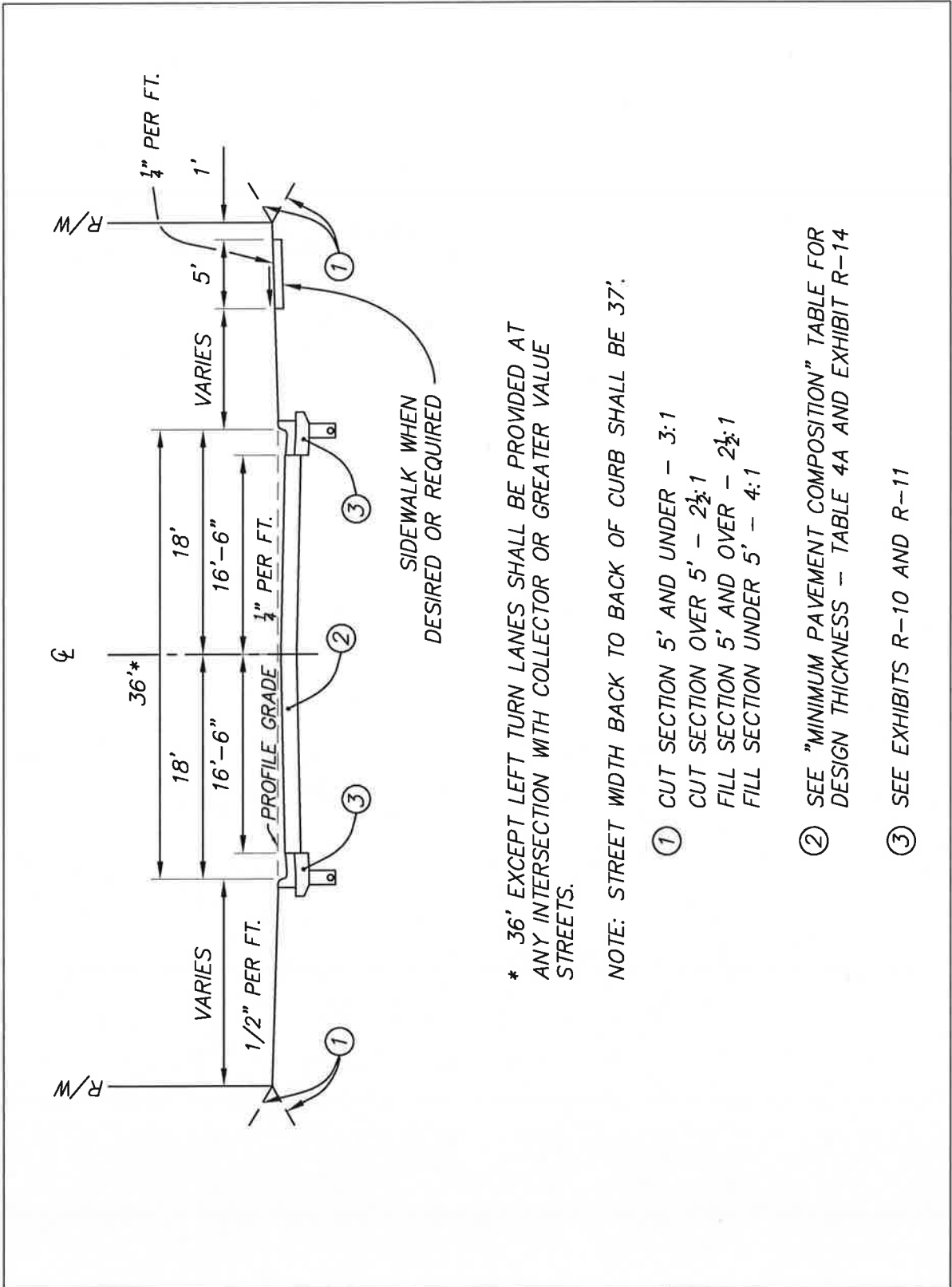

* 36' EXCEPT LEFT TURN LANES SHALL BE PROVIDED AT ANY INTERSECTION WITH COLLECTOR OR GREATER VALUE STREETS.

NOTE: STREET WIDTH BACK TO BACK OF CURB SHALL BE 37'.

- ① CUT SECTION 5' AND UNDER - 3:1
CUT SECTION OVER 5' - 2½:1
FILL SECTION 5' AND OVER - 2½:1
FILL SECTION UNDER 5' - 4:1

② SEE "MINIMUM PAVEMENT COMPOSITION" TABLE FOR DESIGN THICKNESS - TABLE 4A AND EXHIBIT R-14

③ SEE EXHIBITS R-10 AND R-11

36' PAVEMENT SECTION WITH CURB AND GUTTER COLLECTOR STREET - 60' RIGHT OF WAY

EXHIBIT R-6
REV. 5-07-24

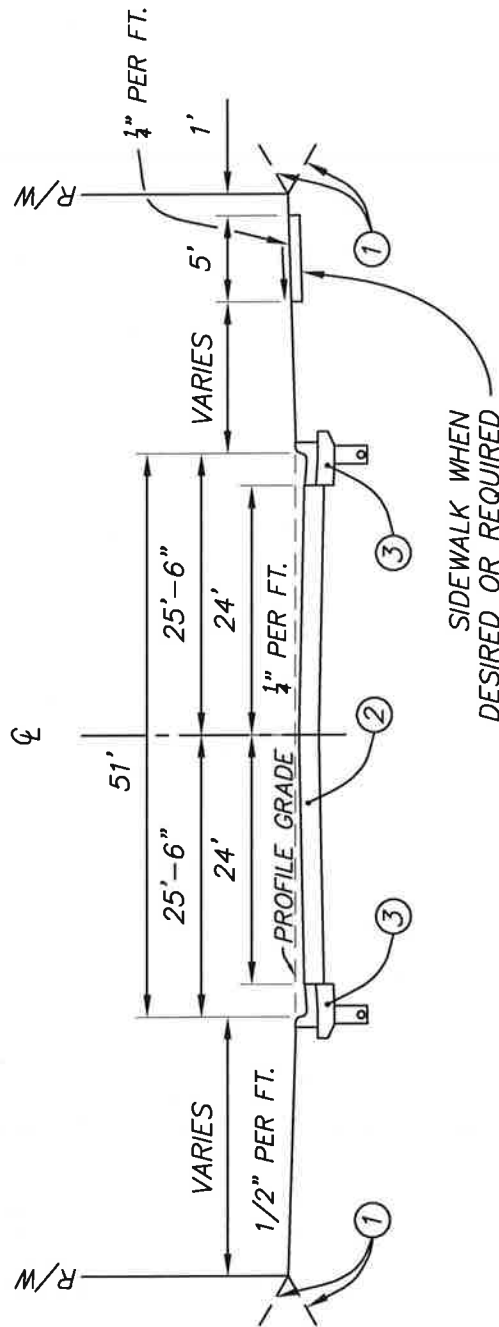

NOTE: STREET WIDTH BACK TO BACK OF CURB SHALL BE 52'.

- ① CUT SECTION 5' AND UNDER - 3:1
CUT SECTION OVER 5' - 2½:1
FILL SECTION 5' AND OVER - 2½:1
FILL SECTION UNDER 5' - 4:1
- ② SEE "MINIMUM PAVEMENT COMPOSITION" TABLE FOR DESIGN THICKNESS - TABLE VI AND EXHIBIT 2E
- ③ SEE EXHIBITS 2A AND 2B

51' PAVEMENT SECTION WITH CURB AND GUTTER
MINOR ARTERIAL - 80' RIGHT OF WAY

EXHIBIT R-7
REV. 5-07-24

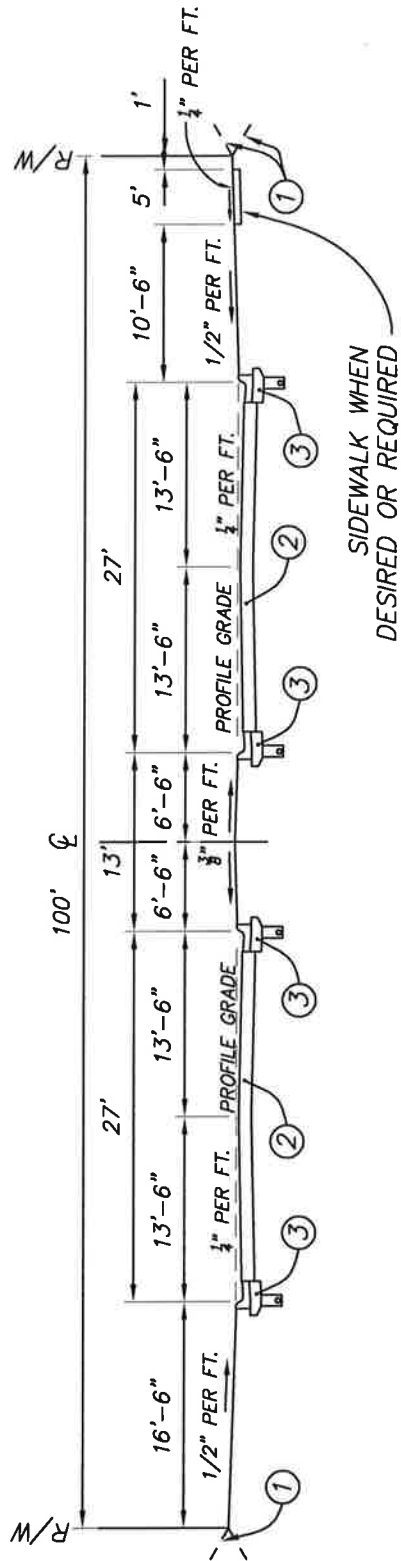

- ① CUT SECTION 5' AND UNDER - 3:1
 CUT SECTION OVER 5' - 2½:1
 FILL SECTION 5' AND OVER - 2½:1
 FILL SECTION UNDER 5' - 4:1

② SEE "MINIMUM PAVEMENT COMPOSITION" TABLE FOR DESIGN THICKNESS - TABLE 4A AND EXHIBIT R-14

③ SEE EXHIBITS R-10 AND R-11

27' & 27' PAVEMENT SECTION WITH CURB AND GUTTER
 MAJOR ARTERIAL - 100' RIGHT OF WAY

EXHIBIT R-8
 REV. 5-07-24

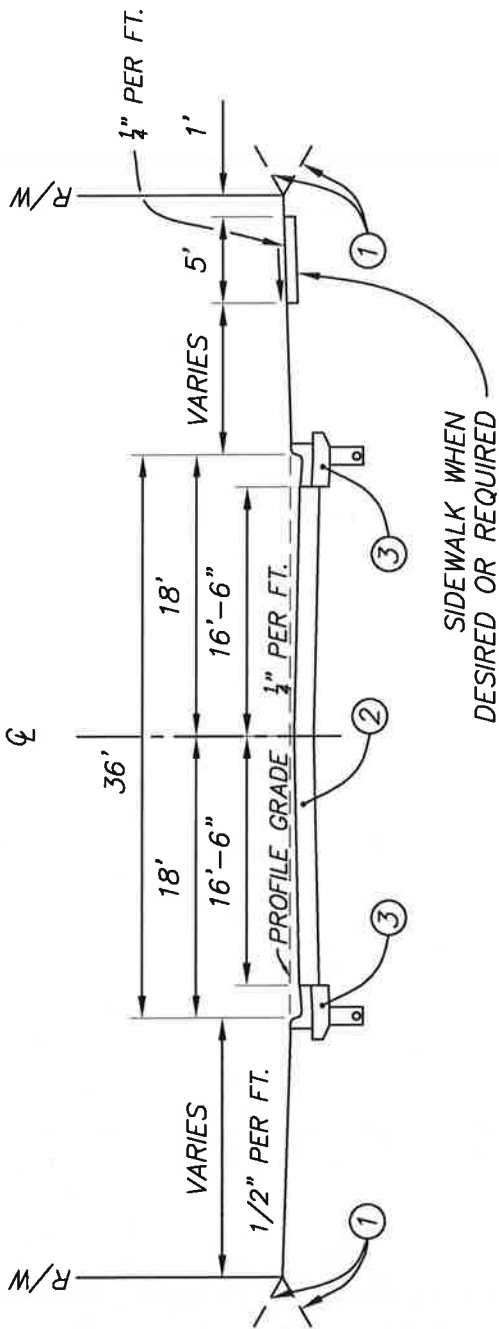

NOTE: STREET WIDTH BACK TO BACK OF CURB SHALL BE 37'.

- ① CUT SECTION 5' AND UNDER - 3:1
CUT SECTION OVER 5' - 2½:1
FILL SECTION 5' AND OVER - 2½:1
FILL SECTION UNDER 5' - 4:1
- ② SEE "MINIMUM PAVEMENT COMPOSITION" TABLE FOR DESIGN THICKNESS - TABLE 4A AND EXHIBIT R-14
- ③ SEE EXHIBITS R-10 AND R-11

36' PAVEMENT SECTION WITH CURB AND GUTTER
INDUSTRIAL STREET - 72' RIGHT OF WAY

EXHIBIT R-9
REV. 5-07-24

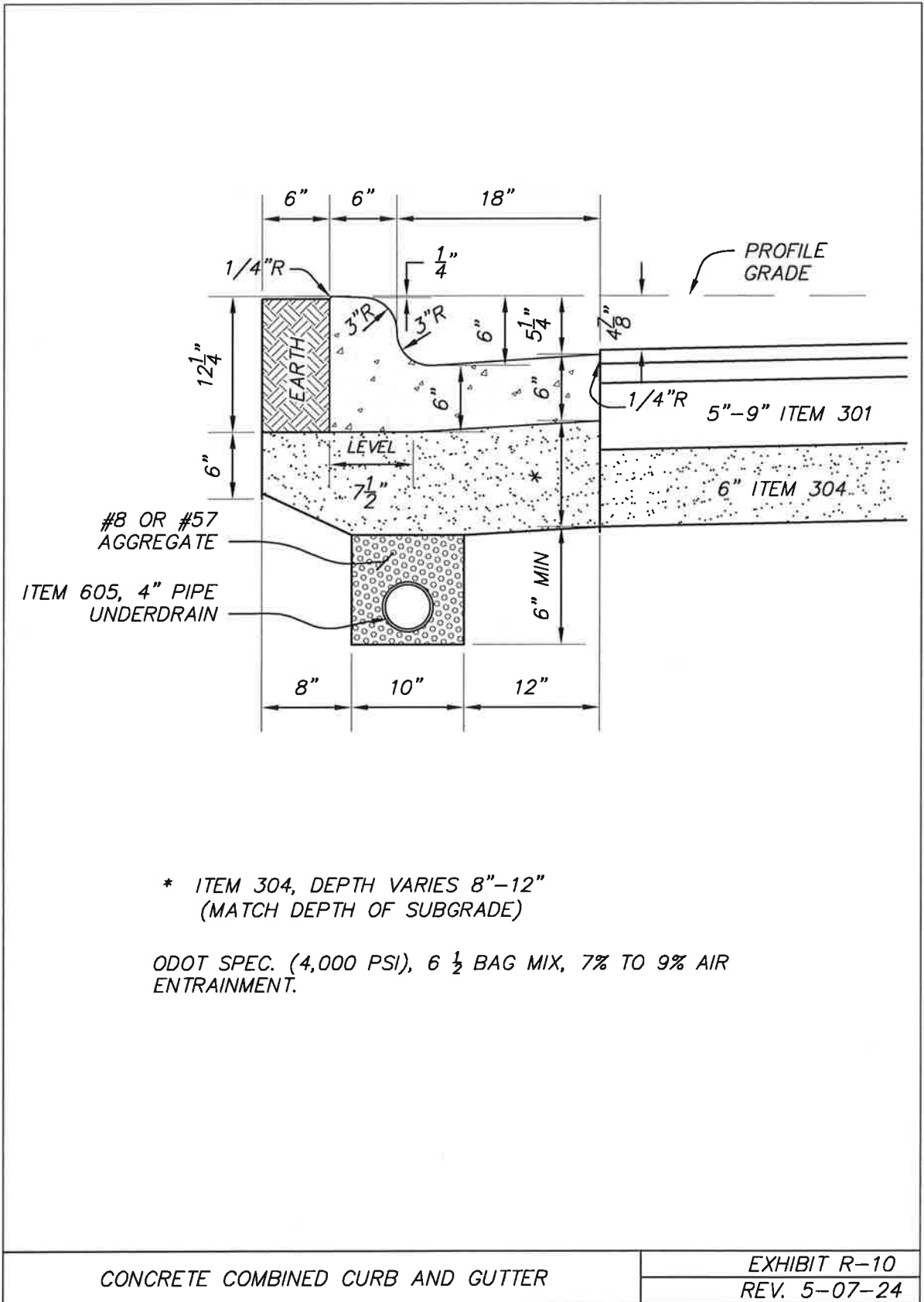

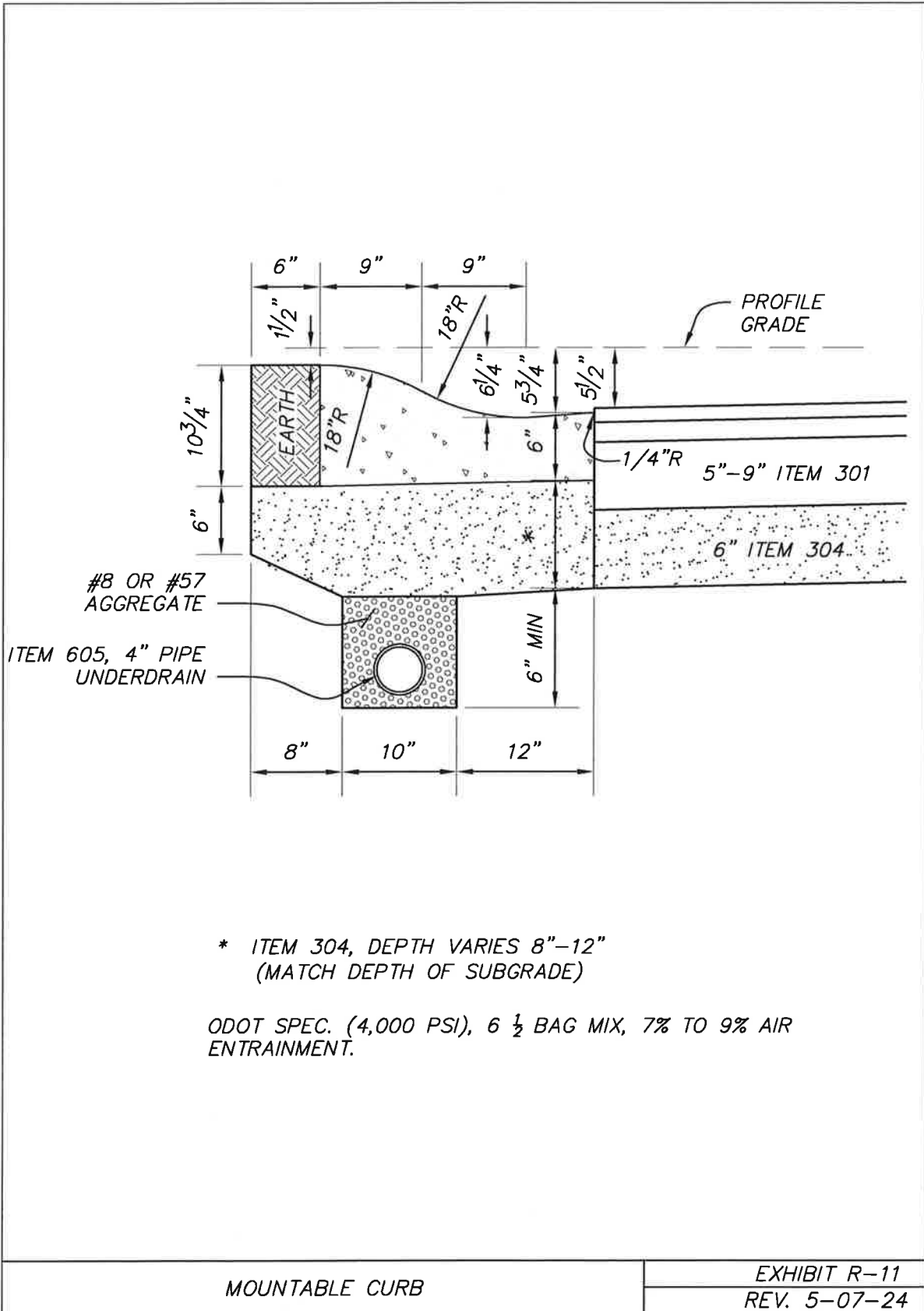

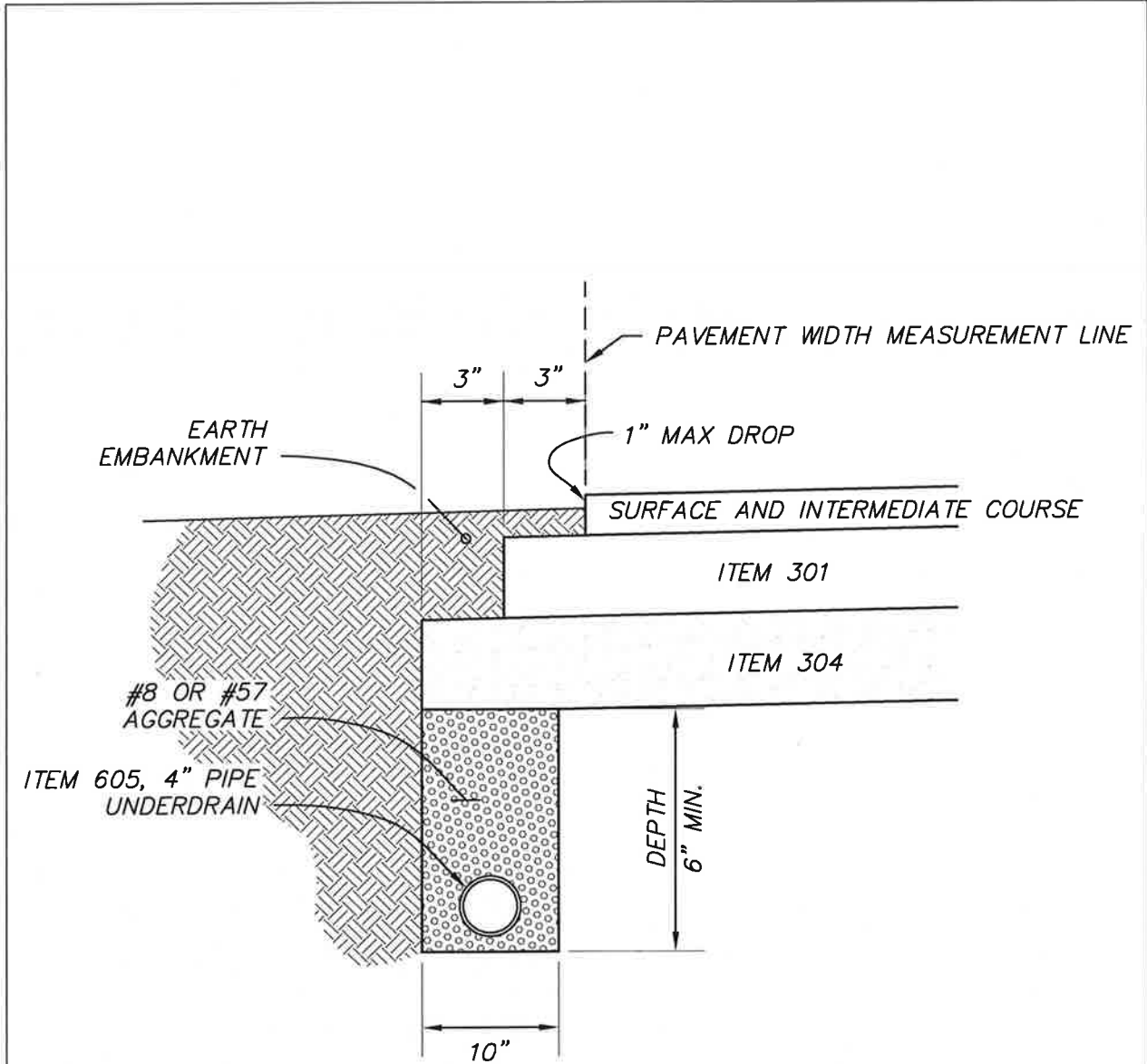

NOTE:

CONCRETE AND CONCRETE BASE STREETS ONLY REQUIRE A 3" WIDTH EXTENSION OF ITEM 304.

PAVEMENT WIDTH AS REQUIRED BY REGULATIONS IS FOR WIDTH OF SURFACE COURSE (DOES NOT INCLUDE REQUIRED 3" EXTENSIONS OF BASE ON EACH SIDE OF PAVEMENT).

EDGE OF PAVEMENT DEEP STRENGTH ASPHALT
W/ UNDERDRAIN

EXHIBIT R-12
REV. 5-07-24

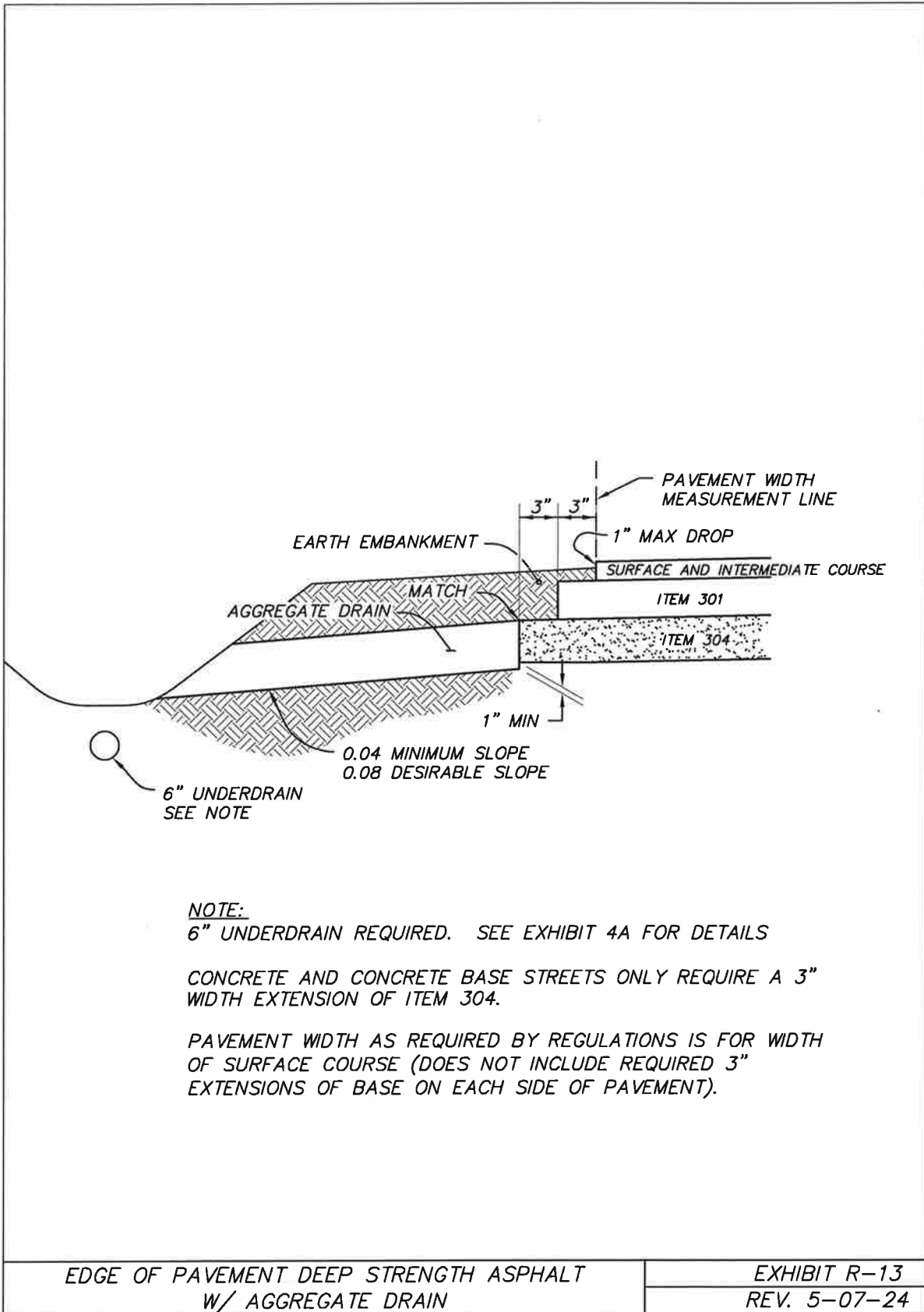

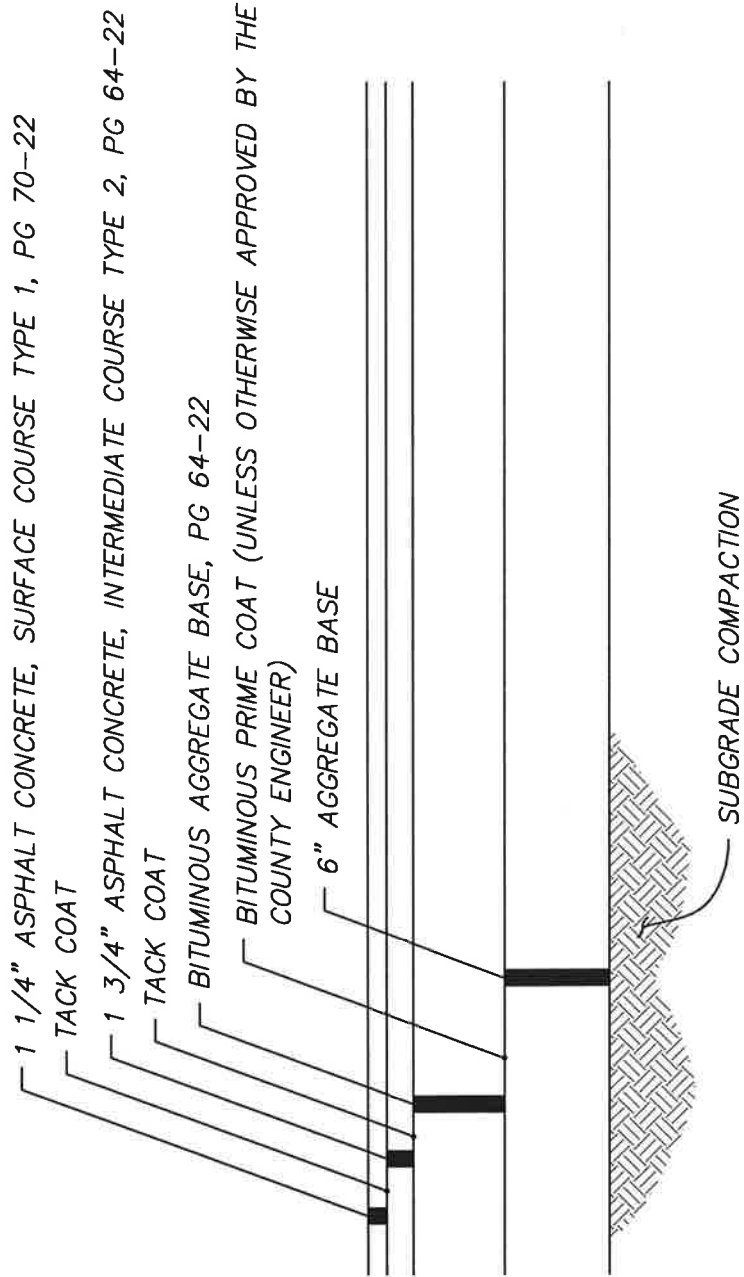

CURRENT ODOT ITEM NUMBERS SHALL APPLY ABOVE.

TYPICAL PAVEMENT SECTION

EXHIBIT R-14
REV. 5-07-24

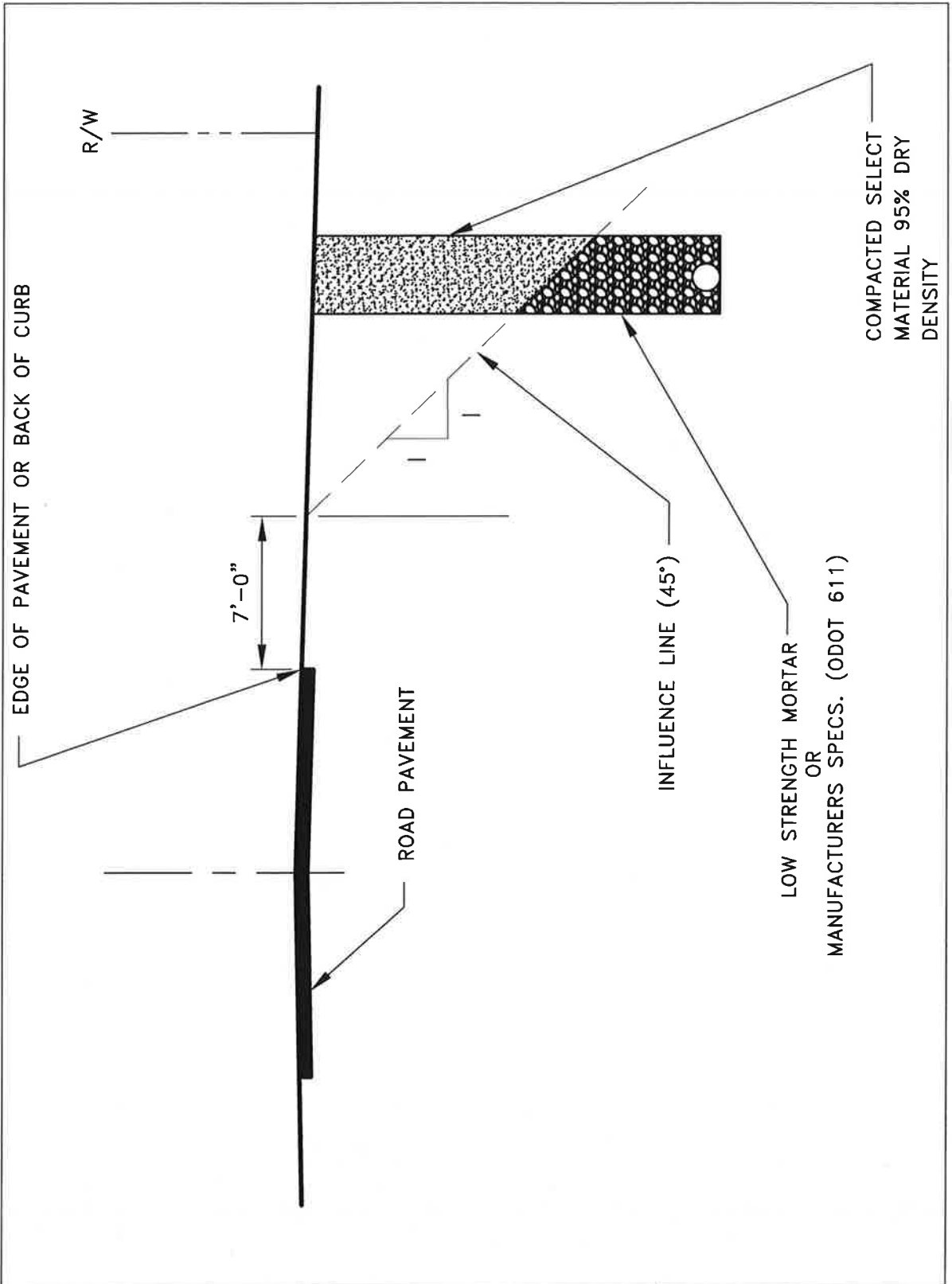

BACKFILL REQUIREMENTS
WITHIN RIGHT-OF-WAY

EXHIBIT R-15
REV. 5-07-24

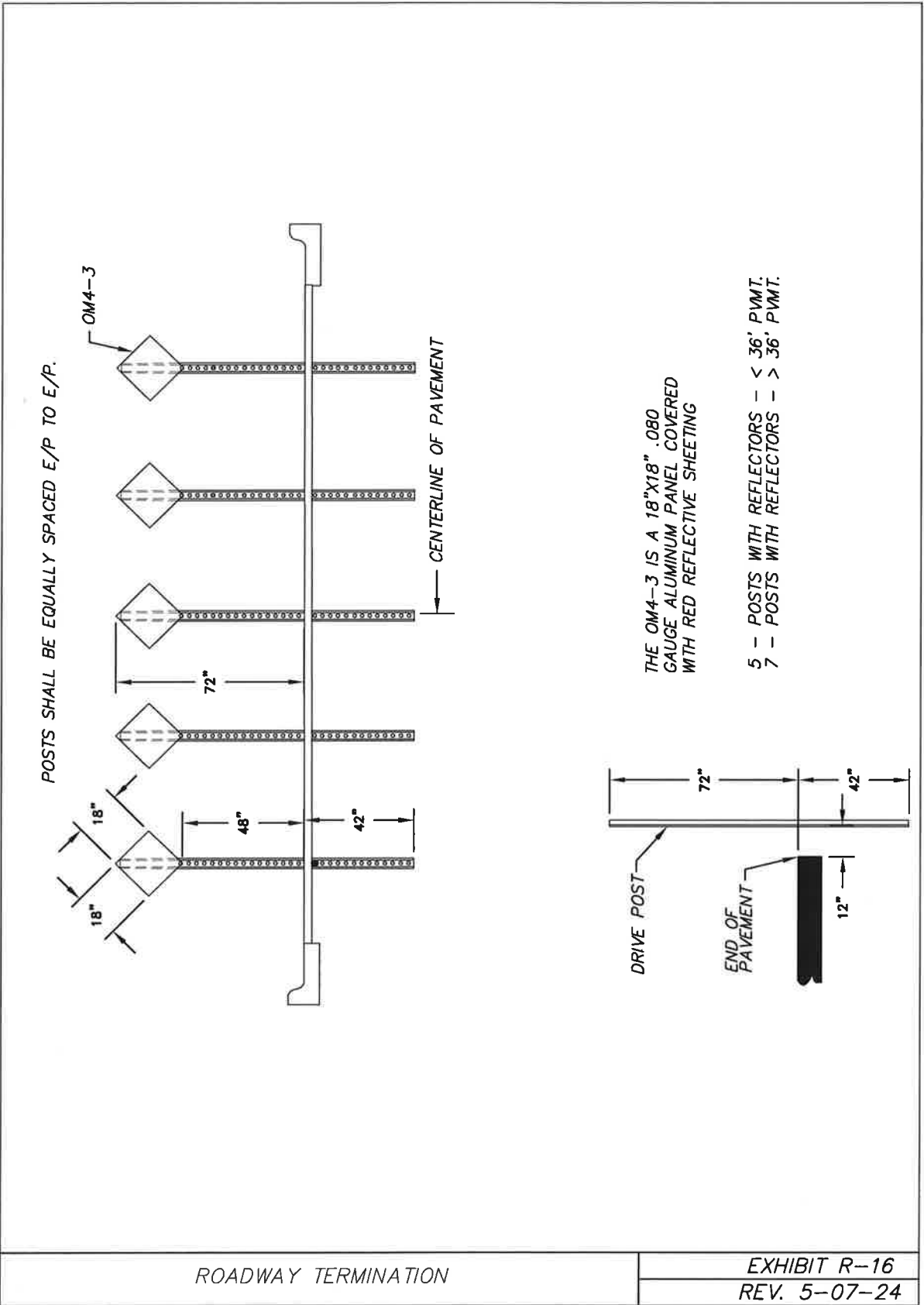

ROADWAY TERMINATION

EXHIBIT R-16
REV. 5-07-24

APPENDIX B
DESIGN EXCEPTION REQUEST FORM



FAIRFIELD COUNTY DESIGN EXCEPTION REQUEST FORM

Submit to Fairfield County Engineer for Processing

I.D. NUMBER

Assigned by
County
Engineer's
Office.

Date: _____

Check here if this is a resubmitted request

Project Name & Location:

Project Description:

List SWDM Section and Title for which a D.E. is requested:

Provide a detailed description of D.E. along with justification and any effects on other requirements:

List Documents Attached. Include appropriate plans, typical sections, cross sections, alignments, and/or details.

Engineer of Record

Engineer of Record Name & P.E. Registration #		
Title:	Date:	
Company Name:		
Company Address:		
City:	State:	Zip:
Email Address:	Phone:	

Disposition of Review by County Engineer:

Denied More information necessary

Reason for Denial or Description of Additional Information Needed:
--

Approved by Fairfield County Engineer

County Engineer Name:	Date:
Comments:	



Ohio

PO Box 630599 Cincinnati, OH 45263-0599

GANNETT

PROOF OF PUBLICATION

Rochelle M Menningen
Accounts Payable *Legal Ads*
Fairfield County Commissioners
210 E Main St
Lancaster OH 43130-3854

STATE OF WISCONSIN, COUNTY OF BROWN

The Lancaster Eagle-Gazette, printed and published in Ohio and personal knowledge of the facts herein state and that the notice hereto annexed was Published in said newspapers in the issues dated on:

04/05/2024

and that the fees charged are legal.
Sworn to and subscribed before on 04/05/2024

Legal Clerk

Notary, State of WI, County of Brown

2-14-28

My commission expires

Publication Cost:	\$81.90	
Order No:	10008046	# of Copies:
Customer No:	1049862	1
PO #:		

THIS IS NOT AN INVOICE!

Please do not use this form for payment remittance.

KEEGAN MORAN
Notary Public
State of Wisconsin

NOTICE OF FAIRFIELD COUNTY, OH, PUBLIC HEARING

For Adoption of a Roadway Design Manual

Fairfield County will hold a public hearing regarding the adoption of a *Roadway Design Manual for Unincorporated Areas of Fairfield County, Ohio*, Tuesday, April 23, 2024, 9:30 am, Administrative Courthouse, 210 E. Main Street, 3rd Floor, Lancaster, Ohio. The purpose of the design manual is to establish rules, guidelines, and standards to govern design, construction, operation, maintenance, and use of streets, curbs, gutters, sidewalks, streetlights, and other facilities in the unincorporated areas of Fairfield County. Authority to establish standards for design and construction within a jurisdiction are granted by Ohio Revised Code (ORC) 711.101. (LEG, Apr, 5'24#10008046)

Signature Page

Resolution No. 2024-05.07.e

A Resolution to Approve and Adopt the Fairfield County, Ohio, Road Design Manual, for Unincorporated Areas of Fairfield County, Ohio, Final Version Effective April 23, 2024

(Fairfield County Engineer)

This resolution has not yet been voted on.

CERTIFICATE OF CLERK

It is hereby certified that the foregoing is a true and correct transcript of a resolution acted upon by the Board of County Commissioners, Fairfield County, Ohio on the date noted above.

A resolution to appropriate from unappropriated in a major expenditure object category County Engineer 2024-Motor Vehicle for general office supplies

WHEREAS, additional appropriations are needed in the major expenditure object category for 2024 Motor Vehicle; and

WHEREAS, appropriate from unappropriated will allow proper accounting in the major expenditure object category.

NOW THEREFORE, BE IT RESOLVED BY THE BOARD OF COUNTY COMMISSIONERS, COUNTY OF FAIRFIELD, STATE OF OHIO:

Section 1: The Fairfield County Board of Commissioners appropriate from unappropriated into the following category:

\$5,000.00 16202401- Materials & Supplies

For Auditor's Office Use Only:

16202401-561000 \$5,000.00

Prepared by: Julie Huggins
cc: Engineer

Signature Page

Resolution No. 2024-05.07.f

A resolution to appropriate from unappropriated in a major expenditure object category County Engineer 2024-Motor Vehicle for general office supplies

(Fairfield County Engineer)

This resolution has not yet been voted on.

CERTIFICATE OF CLERK

It is hereby certified that the foregoing is a true and correct transcript of a resolution acted upon by the Board of County Commissioners, Fairfield County, Ohio on the date noted above.

A resolution to approve an Agreement between Fairfield County and Terracon Consultants, Inc.

WHEREAS, the Fairfield County Engineer is recommending that this Board of Commissioners hire Terracon Consultants, Inc.; 800 Morrison Road; Gahanna, OH 43230, to provide construction inspection and testing services as directed by the Fairfield County Engineer's Office for the stated fees and per the terms in the attached Agreement.

NOW THEREFORE, BE IT RESOLVED BY THE BOARD OF COUNTY COMMISSIONERS, COUNTY OF FAIRFIELD, STATE OF OHIO:

SECTION 1: that this Board of Commissioners resolves to approve and sign the Agreement with Terracon Consultants, Inc. to provide construction inspection and testing services for the Fairfield County Engineer, for the stated fees and per the terms of the attached Agreement.

SECTION 2: that the Clerk of this Board furnish the County Engineer with a copy of this signed Agreement for further action.

Prepared by: Cheryl Downour
cc: Engineering Office

AGREEMENT

Fairfield County Commissioner's and Terracon Consultants, Inc

This **AGREEMENT** entered into at Lancaster, Ohio on this 16th day of April 2024 by and between the County of Fairfield, State of Ohio, acting through the County Engineer, hereinafter referred to as COUNTY, and TERRACON CONSULTANTS, INC, duly licensed and existing under the laws of the State of Ohio for the practice of engineering services, hereinafter, referred to as CONSULTANT, with an office located at 800 Morrison Rd, Gahanna, OH 43230.

PROJECT OVERVIEW

Project: Construction Inspection and Testing Services
Project Manager: Mitch Noland, P.E., S.I.
Proposal Submittal Date: January 1, 2024
Project Completion Date: December 31st, 2024
Project Description: Provide Construction Inspection and Testing Services

SCOPE OF SERVICES

The CONSULTANT agrees to provide engineering services for the above-mentioned project, which includes the following:

Provide Construction Inspection, Material Sampling and Material Testing as directed by the Fairfield County Engineer's Office in accordance with the standards of the Fairfield County Engineer's Office.

COMPENSATION

The COUNTY agrees to compensate the consultant for the performance of the work as specified in the SCOPE OF SERVICES section of this agreement, as follows:

For actual time providing technical or engineering services and on designated projects, not to exceed a total of \$100,000.

See attached for the hourly rates to be paid for services.

PROJECT PROGRESSION

The CONSULTANT shall submit weekly progress reports in the form and content acceptable to the COUNTY. They COUNTY shall be billed in consecutive 4-week increments. No payment will be processed without a weekly progress report. If the progress report reveals that the project is NOT progressing satisfactorily or if invoicing is not commensurate with the progression of work, then payment to the CONSULTANT on this agreement will be SUSPENDED. At no such time shall this be cause for the CONSULTANT to stop work on the project. In the event suspension of payment is invoked, the CONSULTANT shall then supply to the COUNTY the reason(s) for unsatisfactory performance.

Should the reason(s) for unsatisfactory progression of the work be deemed by the COUNTY to be beyond the control of the CONSULTANT or be deemed by the COUNTY to have been unforeseen at the time the project was awarded, documentation detailing a Change in Scope will be drafted in which the CONSULTANT must thoroughly explain and justify the remaining items of work needed to complete the project. In the event of a Project Overrun, the CONSULTANT shall identify and justify all additional costs above the original estimated cost required to finish the project. Once explanations and justifications of the reasons for unsatisfactory progression of work and/or additional costs have been reviewed and accepted by the COUNTY, then an ADDENDUM shall be made to this AGREEMENT to complete the project on the time frame and fee acceptable to both the COUNTY and the CONSULTANT.

Should the reason(s) for the unsatisfactory progression of the work be deemed by the COUNTY to be in FULL control of the CONSULTANT, then the CONSULTANT is bound by this AGREEMENT to complete the work described for the sum set forth in a time frame acceptable to the COUNTY.

TERMINATION OF AGREEMENT

This Agreement may be terminated by either party upon seven (7) days' written notice should the other party fail substantially to perform in accordance with its terms through no fault of the other. In the event of termination due to the fault of others than the CONSULTANT, the CONSULTANT shall be paid his compensation for services performed to termination date including reimbursable expenses then due and all terminal expenses. On termination, all data, drawings, specifications, reports, estimates, summaries and such other information and materials as may have been accumulated by the CONSULTANT in performing this Agreement whether completed or in process must be delivered to and become property of the COUNTY.

The date of the CONSULTANT's endorsement shall serve as notice of authorization to proceed.

The undersigned, having full knowledge of the site, preliminary plans and specifications for the proposed Project and the conditions of this proposal hereby agrees to furnish all services, labor, materials and equipment necessary to complete the work described in the Scope of Services by the completion date specified above and to accept the price specified above as full compensation for the work described in this request for proposal.

IN WITNESS WHEREOF, the parties hereto have made and executed this AGREEMENT on this 16 day of April, 2024.

FAIRFIELD COUNTY COMMISIONERS

COMPANY/CONSULT AGREEMENT

By: Ala Riley

Title: Office Manager

[Signature]
Witness

ATTACHMENTS

The following items are to be considered a part of this contract: *Attachment "A"*

Terracon Construction Inspection and Testing Services Rates



April 2020

Fairfield County Engineer's Office
1000 West Fair Street
Lancaster, OH 43084

Attn: Mr. Michael J. Sidor
Deputy County Engineer
Office
Email: mj.sidor@fairfieldcog.org

**Contract Agreement and Unit Rates for Inspection and Testing Services
Fairfield County – Inspection and Materials Testing Task Order Project
Terracon Proposal No. PN4241104**

Michael

Terracon Consultants appreciates the opportunity to provide inspection and material testing services for the Fairfield County Engineer's Office.

A. PROJECT INFORMATION

This order and the project will include inspection and material testing of road applications at the subdivision development construction site. It is anticipated the project will be in accordance with the standard of the Ohio Revised Code for this project will consist of providing construction inspection and testing to ensure proper construction of road applications in the days and specifications as provided in the Fairfield County Engineer's Office.

B. SCOPE OF SERVICES

The following services will be provided by Terracon at the direction of the Fairfield County Engineer's Office:

- Review of contract documents and completed plans
- Field project meetings
- Review of submittals and material submittals for approval prior to work
- Inspection of Contractor's work
- Daily or Weekly progress reports
- Material testing and materials acceptance
- Development of project cost list for Contractor's cost control
- Project close-out cost control of final project list and finalization of project files documents to be provided

Proposal for Construction Inspection/Testing Services

Gas Order Contract for Inspection and Material Testing ■ Fairfield County
Ohio



Our approach to providing construction inspection services is an assigned qualified inspection technicians to perform the necessary observations and as required testing for your project. Our inspection and requested field and laboratory testing will be performed in general accordance with ODO specifications as requested below and our experience with similar projects. The technicians assigned to the project will be qualified and equipped to perform the following field services:

Roadway Construction Observations:

- Observe and document construction operations to ensure compliance per provided specifications and plans.

Concrete Observations and Testing if requested:

- Sample fresh concrete and perform field tests including slump, air content, and temperature. ■ S/M Concrete Cylinders and C
- Cast test specimens during placement at a rate of 1 set of 3 cylinders for each cubic yard of structural concrete placed or 1 set per day of placement.
- Perform compressive strength tests of concrete test cylinders cast in the field. ■ S/M Concrete

Soils Observations and Testing:

- Observe and record of soil rolling operations to identify soft or field areas.
- Determine the amount of dross and soil to be disposed of according to SMO or MCMC.
- Perform in-situ clear density tests to determine the moisture content and percent compaction of the soil. ■ SMO or MCMC

Granular Material Density Testing:

- Perform in-situ clear density tests to determine percent compaction of granular material per SMO or MCMC. ■ SMO or MCMC

Asphalt Mat Density Testing:

- Perform in-situ core density tests per SMO or MCMC. ■ SMO or MCMC

C. COMPENSATION

Our services will be provided on a time and materials basis in accordance with the attached fee schedule and shall not exceed a total of \$1,000,000.

We appreciate the opportunity to provide these inspection services for the Fairfield County Engineer's Office and look forward to a successful project. Please call us at (614) 266-1234 if you have any questions or concerns.

Proposal for Construction Inspection/Testing Services

Gas Order Contract for Inspection and Material Testing - Fairfield County Ohio
April 2024



D. AUTHORIZATION

The undersigned formal authorization to proceed on this project will be Terracon receipt of the attached executed copy of the Fairfield County Commissioners.

Please feel free to contact us if you have any questions or a need to pay for this authorization.

Respectfully Submitted
Terracon Consultants, Inc

Steve Siskind
Senior Partner

Clay Rile
Office Manager/Principal

Attachments

Rate Fee Schedule



Fairfield County Engineer's Office April 2011

TERRACON CONSULTANTS
UNIT RATE FEE SCHEDULE

CONSTRUCTION MATERIALS INSPECTION/TESTING SERVICES

Personnel Fees

Table with 2 columns: Description (Professional Engineer, Recor'd Engineer, Recorder/Materials, Senior Materials Comptroller, Materials Comptroller, Construction Inspector - Level 1, Construction Inspector - Level 2, Secretarial Services, Vehicle Charge) and Rate (\$100.00/hr, \$75.00/hr, \$75.00/hr, \$100.00/hr, \$100.00/hr, \$50.00/hr, \$50.00/hr, \$50.00/hr, \$100.00/mi)

Miscellaneous Fees

Table with 2 columns: Description (Design Office, Concrete Control Design Office, Trade Show Center) and Rate (\$100.00/day, \$100.00/day, \$100.00/day)

Standard Proctor

Table with 2 columns: Description (12" Mold, 6" Mold, Transfer Limits) and Rate (\$100.00/eac, \$100.00/eac, \$100.00/eac)

Asphalt Cores - Density

Table with 2 columns: Description (Rice Grain MS, Specific Gravity) and Rate (\$100.00/eac, \$100.00/eac)

Concrete

Table with 2 columns: Description (Compressive Design of Cylinders in the Laboratory F.O., Design of Cores of SM Concrete, Rebar Tests, Flexural Strength Design of Beams in Terracon Lab, Flexural Strength Design of Beams in Site) and Rate (\$100.00/eac, \$100.00/eac, \$100.00/eac, \$100.00/eac, \$100.00/hr)

Over the increase of hours considered per day Saturdays, Sundays or holidays will be billed at the referenced rates plus as well as services performed between the hours of 8:00 am and 5:00 pm on any day the charge applies to field services apply.

□

ORIGINAL

Carri L. Brown, PhD, MBA, CGFM

Purchase Order

Fairfield County Auditor
210 East Main Street
Lancaster, Ohio 43130

Fiscal Year 2024

Page: 1 of 1

THIS NUMBER MUST APPEAR ON ALL INVOICES,
PACKAGES AND SHIPPING PAPERS.

Purchase Order # **24004361 - 00**

Delivery must be made within doors of specified destination.

Expiration Date: 12/15/2025

**B
I
L
L
T
O**
COUNTY ENGINEER
3026 W FAIR AVE
LANCASTER, OH 43130
Phone: 740-652-2300

**V
E
N
D
O
R**
TERRACON CONSULTANTS INC
18001 W 106TH ST STE 300
OLATHE, KS 66061

**S
H
I
P
T
O**
COUNTY ENGINEER
3026 W FAIR AVE
LANCASTER, OH 43130
Phone: 740-652-2300

VENDOR PHONE NUMBER	VENDOR FAX NUMBER	REQUISITION NUMBER	DELIVERY REFERENCE	
513-321-5816		4737		
DATE ORDERED	VENDOR NUMBER	DATE REQUIRED	FREIGHT METHOD/TERMS	DEPARTMENT/LOCATION
05/01/2024	7169			ENGINEER-ADMIN
NOTES				

PO Requisitioner Name : Julie Huggins
E mail Address : julie.huggins@fairfieldcountyohio.gov

ITEM #	DESCRIPTION / PART #	QTY	UOM	UNIT PRICE	EXTENDED PRICE
1	SUBDIVISION CONSTRUCTION INSPECTION, MATERIAL SAMPLING AND MATERIAL TESTING GL Account: 16202405 - 530020	1.0	EACH	\$100,000.00	\$100,000.00
GL SUMMARY					
	16202405 - 530020			\$100,000.00	

Invoice Date ___/___/___ Invoice Amount \$ _____ To Be paid ___/___/___ Warrant # _____

COUNTY AUDITOR'S CERTIFICATE

It is hereby certified that the amount \$100,000.00 required to meet the contract, agreement, obligation, payment or expenditure, for the above, has been lawfully appropriated, authorized or directed for such purpose and is in the County Treasury or in process of collection to the credit of the submitted Fund(s) free from any obligation or certification now outstanding.

Date: 05/01/2024

Carri L. Brown

Auditor Fairfield County, OH

Purchase Order Total **\$100,000.00**

5/7/2024

150

For Department Use ONLY

ROUTING FORM FOR CONTRACTS

The undersigned designee of the County affirms that he/she has reviewed the attached contract to ensure that it complies with County's needs and previous negotiations. The undersigned designee further affirms that the County has complied with the competitive selection process, as prescribed by Ohio Revised Code 9.17, and the applicable sections as outlined on this form, by selecting the applicable boxes below.

- A. Goods and/or Services in excess of \$75,000.00—competitively selected via an Invitation to Bid, pursuant to R.C. 307.86-307.92
- B. Goods and/or Services in excess of \$75,000.00—competitively selected via a Request for Proposals, pursuant to R.C. 307.862
- C. Public Improvement contracts—competitively selected pursuant to R.C. 153.08-153.12
- D. Architect/Engineer design services for public improvements—selected through the Request for Qualifications process pursuant to R.C. 153.65-153.72
- E. County Road Improvement/Construction—competitively selected pursuant to R.C. 5555.61
- F. The subject matter was exempt from competitive selection for the following reason(s):
1. Under \$75,000
 2. State Term #: _____ (copy of State Term Contract must be attached)
 3. ODOT Term #: _____ (See R.C. 5513.01)
 4. Professional Services (See the list of exempted occupations/services under R.C. 307.86)
 5. Emergency (Follow procedure under ORC 307.86(A))
 6. Sole Source (attach documentation as to why contract is sole source)
 7. Other: _____ (cite to authority or explain why matter is exempt from competitive bidding)
- G. Agreement not subject to Sections A-F (explain): _____
- H. Compliance with Fairfield County Board of Commissioners Procurement Guidelines
1. No County employee, employee's family member, or employee's business associate has an interest in this contract OR such interest has been disclosed and reviewed by the Prosecutor's Office
 2. No Finding for Recovery against Vendor as required under R.C. 9.24 (search via "Certified Search" on <http://ffr.ohioauditor.gov/>)
 3. Obtained 3 quotes for purchases under \$75,000 (as applicable)
 4. Purchase Order is included with Agreement

Signed this _____ day of _____, 20_____.

Terracon Agreement

Name and Title

*** Please note that this checklist only addresses County and statutory requirements. If a contract is paid for with state and/or federal funds, please consult with the appropriate state and/or federal agency to ensure your department is complying with any additional requirements. By submitting a request for approval, you are certifying you have addressed County, statutory, and grant requirements.***

Prosecutor's Approval Page

Resolution No.

A resolution to approve an Agreement between Fairfield County and Terracon Consultants, Inc.

(Fairfield County Engineer)

Approved as to form on 5/2/2024 4:15:26 PM by Amy Brown-Thompson,



Amy Brown-Thompson
Prosecutor's Office
Fairfield County, Ohio

Signature Page

Resolution No. 2024-05.07.g

A Resolution to Approve an Agreement between Fairfield County and Terracon Consultants, Inc.

(Fairfield County Engineer)

This resolution has not yet been voted on.

CERTIFICATE OF CLERK

It is hereby certified that the foregoing is a true and correct transcript of a resolution acted upon by the Board of County Commissioners, Fairfield County, Ohio on the date noted above.

A resolution to approve a Change Order for the FAI-CR7-1.94 Refugee Road Intersection Safety Improvement Project.

WHEREAS, on September 5, 2023, this Board of Commissioners awarded the Contract Bid for the FAI-CR7-1.94 Refugee Road Intersection Safety Improvement Project to Complete General Construction Company for a Bid of \$3,581,083.88, and

WHEREAS, actual quantities of items used to complete this project differ from the quantities estimated in the Contract documents, as shown on the attached Change Order, and

WHEREAS, the County Engineer is requesting approval of Change Order Number One to reflect actual quantities used to date on this project, which will increase the Contract price from \$3,581,083.88 to \$3,610,965.64.

NOW THEREFORE, BE IT RESOLVED BY THE BOARD OF COUNTY COMMISSIONERS, COUNTY OF FAIRFIELD, STATE OF OHIO:

SECTION 1: that this Board of Commissioners resolves to approve and does hereby sign this Resolution and the attached Change Order Number One, to increase the Contract price by \$29,881.76, making the revised cost of the FAI-CR7-1.94 Refugee Road Intersection Improvement Project \$3,610,965.64.

SECTION 2: that the Clerk of this Board return the signed copy of this Resolution and the signed Change Order to the County Engineer for further processing.

Prepared by: Cheryl Downour
cc: Engineer's Office

OFFICE OF THE COUNTY ENGINEER

FAIRFIELD COUNTY, OHIO

CHANGE ORDER

Change Order No.: 1

Change Order Date: 4-29-24

Contract For

**FAIRFIELD COUNTY ENGINEERS OFFICE
FAI-CR7-1.94 REFUGEE ROAD INTERSECTION SAFETY IMPROVEMENTS**

Contractor: Complete General Construction

You are hereby requested to comply with the following changes from the contract plans and specifications:

Description of Changes:

- | |
|--|
| <p>1. Ref. #155 FA-CR-20, SIGNAL POLE FOUNDATION ISSUES, is due to poor soil, and utility obstruction, in the area of the signal pole foundations at CR7 & CR20. Per. Approved Force Account totals.
2. Ref.#104 is due to plan error in quantity.</p> |
|--|

Quantity and Cost Changes:

REF #	ITEM #	QUANTITY	UNIT	DESCRIPTION	UNIT \$	Decrease In Price	Increase In Price
155	special	1	LS	FA-CR.20. SIGNAL POLE FOUNDATION ISSUES	\$29,401.76	\$0.00	\$29,401.76
104	625	24	FT	CONDUIT, 2", 725.04	\$20.00	\$0.00	\$480.00
						\$0.00	\$0.00
						\$0.00	\$0.00
						\$0.00	\$0.00

TOTALS: \$0.00 \$29,881.76

Net Change in Contract Price: \$29,881.76

The sum of \$29,881.76 is hereby **added** to the original contract price of _____ making the current contract price: _____ \$3,581,083.88
\$3,610,965.64

The time provided for completion is UNCHANGED by NO calendar days.

This document will become a supplement to the contract and all provisions of the contract apply hereto.

ETM Cady
Recommended - Co. Engr. Dep. Engr.

Date: 5/1/24

Jenior Crites
Complete General Construction

Date: 4/30/24

Fairfield County Commissioners
Date: _____

Signature Page

Resolution No. 2024-05.07.h

A Resolution to Approve a Change Order for the FAI -CR7-1.94 Refugee Road Intersection Safety Improvement Project

(Fairfield County Engineer)

This resolution has not yet been voted on.

CERTIFICATE OF CLERK

It is hereby certified that the foregoing is a true and correct transcript of a resolution acted upon by the Board of County Commissioners, Fairfield County, Ohio on the date noted above.

A Resolution to Approve the Contract with Russell Standard Corporation for the 2024 Crack Sealing Project.

WHEREAS, on April 30, 2024, this Board of Commissioners awarded the Bid for the 2024 Crack Sealing Project to Russell Standard Corporation for \$54,883.84, and

WHEREAS, since the Contract Materials are in order and this Contract Agreement has been approved by the Fairfield County Prosecutor, the County Engineer recommends that this Board of Commissioners sign this Resolution and the Contract Agreement with Russell Standard Corporation.

NOW THEREFORE: BE IT RESOLVED BY THE BOARD OF COUNTY COMMISSIONERS, COUNTY OF FAIRFIELD, STATE OF OHIO:

SECTION 1: that this Board of Commissioners approves the 2024 Crack Sealing Project Contract with Russell Standard Corporation for \$54,883.84 by signing the Contract Agreement and this Resolution for this project to proceed.

SECTION 2: that the Clerk of this Board furnish the County Engineer with the Contract Agreement and Resolution for further processing.

Prepared by: Randy Carter
cc: Engineering Department

CONTRACT

This Contract made this _____ day of _____, 2024, between the Fairfield County Commissioners, hereinafter called the Owner, and Russell Standard Corporation and its successors, executors, administrators and assigns, hereinafter called the Contractor.

WITNESSETH: That the Owner and the Contractor for the consideration stated herein agree as follows:

ARTICLE I: Scope of the Work - The Contractor shall perform within the time stipulated, the Contract as herein defined of which this agreement is a component part and everything required to be performed and shall provide and furnish any and all of the labor and materials together with all tools, equipment and all utility and transportation services necessary to perform the Contract and complete in a workmanlike manner all the work covered by the Contract in connection with the Owner's Project identified as: 2024 Crack Sealing Project in strict conformity with the Proposal, Plans, and Specifications including any and all Addenda issued by the Owner with the other Contract Documents.

It is agreed that said labor, materials, tools, equipment, and services shall be furnished by the Contractor and the Contract performed and completed under the direction and supervision and subject to the approval of the Owner or its authorized representatives.

ARTICLE II: Unit Prices - The Owner shall pay to the Contractor, as full consideration for performance of the Contract, an amount computed upon the basis of the Quantity of work actually performed at the unit price bids in the Proposal Form.

It is understood that the quantities stated for the unit price bids are approximate only and are subject to either increase or decrease; and should the quantity of any item of the unit price work be increased, the Contractor shall perform the additional work at the unit price bid in the Proposal, and should the quantity be decreased, payment will be made on actual quantities completed at the unit price bid in the Proposal, and the Contractor will make no claim for anticipated profits for any decrease in quantities. Actual quantities will be determined upon completion of the work.

ARTICLE III: Performance Bond - The Contractor shall furnish an acceptable Performance Bond in the amount of One Hundred Percent (100%) of the amount Bid at the time of signing of this Contract.

ARTICLE IV: Prevailing Wage - The Contractor shall pay the Prevailing Wage on this Contract and in accordance with all Prevailing Wage Laws in this area.

ARTICLE V: Failure to Complete on Time - If the Contractor fails to complete the work within the time allowed, must be completed not later than September 27, 2024, the Owner for each Calendar Day that any work shall remain uncompleted after the Contract completion date shall charge liquidated damages, from money due the Contractor, per the State of Ohio Department of Transportation Construction and Material Specifications Book specified in the General Specifications document included with this contract. The Owner may waive such portions of the liquidated damages as may accrue after the work is in condition for safe and convenient use by the Public.

ARTICLE VI: The Contractor covenants and agrees that this Contract shall consist of the documents as listed below which are attached hereto, incorporated herein by reference and made a part hereof:

**The Contract
The Construction Plans
The Bid Proposal
General Specifications
Performance and Payment Bond
Non-Collusion Affidavit
Certificates
Experience Record
Affidavit of Personal Property Tax Liability
Affidavit of Lien Release
Anti-Alcohol/Drug Policy
General Conditions
Prevailing Wage Determination
Request for Taxpayer ID Number and Certification (W-9)
Specifications/Location Plans**

ARTICLE VII: In consideration of the premises and in accordance with the provisions of Article 30 of the General Conditions, the Owner agrees to pay to the Contractor the appropriate Fifty Four Thousand Eight Hundred Eighty Three and 84/100 upon completion of the 2024 Crack Sealing Project after inspection and acceptance by the Owner.

ARTICLE VIII: The Contractor further covenants and agrees that he shall give the Owner no less than forty-eight (48) hours (working days - County calendar) written notice of occupying the construction site necessitating road closure. Notice to proceed shall be the date of receipt of the Contract signed by the County Commissioners.

The Contractor further covenants and agrees that in the hiring of employees for the performance of work under this Contract or any subcontract, no Contractor or Subcontractor or any person acting on his behalf, shall, by reason of race, creed, or color, discriminate against any citizen of the state in the employment of labor or workers who are qualified and available to perform the work to which the employment relates, and, further, that no Contractor, Subcontractor, nor any person acting on his behalf, shall, in any manner discriminate against or intimidate the employee hired for the performance of work under this Contract on account of race, creed or color.

ARTICLE IX: Both parties hereto agree that the provisions of Chapter 4115, Ohio Revised Code, and RELATED SECTIONS, shall be complied with, in all respects under this Contract.

IN WITNESS WHEREOF: The parties hereto have caused their names to be affixed by their duly authorized officers and caused their corporate seals to be affixed hereto.

OWNER: FAIRFIELD COUNTY COMMISSIONERS

BY:

David L. Levacy
President

Jeffrey A. Fix
Commissioner

Steven A. Davis
Commissioner

CONTRACTOR: Russell Standard

BY (signature):

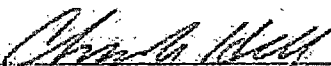

BY (print name):

Charles Hill

ADDRESS:

639-B State Route 821

Marietta, OH 45750

TELEPHONE:

740-374-4253

FAX:

740-374-4005

E-MAIL:

Charlie.Hill@russellstandard.com

C E R T I F I C A T E S

The hereto attached Performance and Payment Bond being good and sufficient is accepted this _____ day of _____, 2024.

FAIRFIELD COUNTY BOARD OF COMMISSIONERS:

David L. Levacy
President

Jeffrey M. Fix
Commissioner

Steven A. Davis
Commissioner

C E R T I F I C A T E O F C O U N T Y A U D I T O R

I HEREBY CERTIFY that funds are available, or are in the process of collection from the Motor Vehicle Fund and/or 1/2-mill Levy Fund, in the amount of \$93,940.00. This figure has been lawfully appropriated, or authorized or directed for the WAL-05 Geiger Road Superstructure Replacement Project free from any obligation.



Carri L. Brown
Fairfield County Auditor

Dated at Lancaster, Ohio: April 25, 2024.

C E R T I F I C A T E O F P R O S E C U T I N G A T T O R N E Y

I HEREBY APPROVE the form of the foregoing contract.

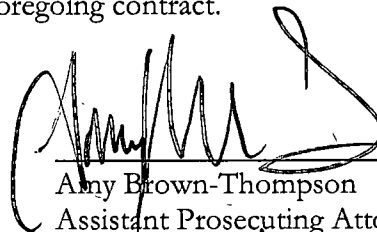

Amy Brown-Thompson
Assistant Prosecuting Attorney

Date: 5/1/24, _____.

Signature Page

Resolution No. 2024-05.07.i

A Resolution to Approve the Contract with Russell Standard Corporation for the
2024 Crack Sealing Project

(Fairfield County Engineer)

This resolution has not yet been voted on.

CERTIFICATE OF CLERK

It is hereby certified that the foregoing is a true and correct transcript of a resolution acted upon by the Board of County Commissioners, Fairfield County, Ohio on the date noted above.

A Resolution to Approve the Contract with Asphalt Materials, Inc. for the Purchase of Liquid Asphalt.

WHEREAS, on April 16, 2024, this Board of Commissioners awarded the Bid for the Purchase of Liquid Asphalt to Asphalt Materials, Inc. for \$572,760.00, and

WHEREAS, since the Contract Materials are in order and this Contract Agreement has been approved by the Fairfield County Prosecutor, the County Engineer recommends that this Board of Commissioners sign this Resolution and the Contract Agreement with Asphalt Materials, Inc.

NOW THEREFORE: BE IT RESOLVED BY THE BOARD OF COUNTY COMMISSIONERS, COUNTY OF FAIRFIELD, STATE OF OHIO:

SECTION 1: that this Board of Commissioners approves the Purchase of Liquid Asphalt Contract with Asphalt Materials, Inc. for \$572,760.00 by signing the Contract Agreement and this Resolution for this project to proceed.

SECTION 2: that the Clerk of this Board furnish the County Engineer with the Contract Agreement and Resolution for further processing.

Prepared by: Randy Carter
cc: Engineering Department

CONTRACT

This Contract, made this _____ day of _____, 2024, between the Fairfield County Commissioners, hereinafter called the Owner, and Asphalt Materials, Inc and its successors, executors, administrators and assigns, hereinafter called the Contractor/Supplier.

WITNESSETH: That the Owner and the Contractor for the consideration stated herein agree as follows:

ARTICLE I: That for and in consideration of payments hereinafter mentioned to be made by the Owner, the Contractor/Supplier agrees to furnish and deliver Liquid Asphalt, for which a Bid has been submitted to and awarded by the Fairfield County Board of County Commissioners under the conditions as set forth more fully in the Bid Package according to the specifications and to the satisfaction and acceptance of the Owner.

ARTICLE II: Failure to Deliver in the time allowed: If the Contractor/Supplier fails to supply and deliver said item(s) in the time specified, this Contract becomes null and void.

ARTICLE III: The Contractor/Supplier covenants and agrees that this Contract shall consist of the documents as listed below which are attached hereto, incorporated herein by reference and made a part hereof:

- Instructions to Bidders
- General Specifications
- The Bid Proposal
- The Contract
- Certificates
- Non-Collusion Affidavit
- Affidavit of Personal Property Tax Liability
- Request for Taxpayer ID Number and Certification (W-9)
- New Vendor Reporting Form

ARTICLE IV: Upon delivery of Bid Item(s), and Inspection and Acceptance by the Owner, the Owner agrees to pay the Contractor/Supplier the appropriate sum of Five Hundred Seventy Two Thousand Seven Hundred Sixty and 00/100 (\$572,760.00), which shall be paid by the Local Public Authorities, which may include various Townships within Fairfield County.

The Contractor/Supplier further covenants and agrees that in the hiring of employees for the performance of work under this Contract or any subcontract, no Contractor/Supplier or Subcontractor or any person acting on his behalf, shall, by reason of race, creed, or color, discriminate against any citizen of the state in the employment of labor or workers who are qualified and available to perform the work to which the employment relates, and, further, that no Contractor/Supplier, Subcontractor, nor any person acting on his behalf, shall, in any manner discriminate against or intimidate the employee hired for the performance of work under this Contract on account of race, creed or color.

ARTICLE IX: Both parties hereto agree that the provisions of Chapter 4115, Ohio Revised Code, and RELATED SECTIONS, shall be complied with, in all respects under this Contract.

IN WITNESS WHEREOF: The parties hereto have caused their names to be affixed by their duly authorized officers and caused their corporate seals to be affixed hereto.

OWNER: FAIRFIELD COUNTY COMMISSIONERS

BY:

David L. Levacy
President

Jeffrey M. Fix
Commissioner

Steven A. Davis
Commissioner

CONTRACTOR:

Asphalt Materials, Inc.

BY (signature):

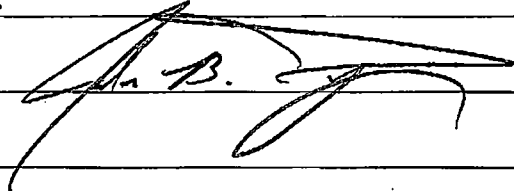

BY (print name):

Joshua B. Gregory

ADDRESS:

13925 State Route 7

Marietta, Ohio 45750

TELEPHONE:

(740) 374-5100

FAX:

N/A

E-MAIL

josh.gregory@asphalt-materials.com

CERTIFICATES

CERTIFICATE OF COUNTY AUDITOR

I HEREBY CERTIFY that the funds are available, or are in the process of collection in the amount of \$572,760.00. Of which, \$417,960.00 are in the process of collection from the Motor Vehicle Fund and/or 1/2-mill Levy Fund; \$77,400.00 from the Board of Liberty Township Trustees; and \$77,400.00 from the Board of Greenfield Township Trustees. This figure has been lawfully appropriated, or authorized or directed for the Purchase of Liquid Asphalt Project free from any obligation.



Carri L. Brown.
Fairfield County Auditor

Dated at Lancaster, Ohio: April 22, 2024.

CERTIFICATE OF PROSECUTING ATTORNEY

I HEREBY APPROVE the form of the foregoing contract.

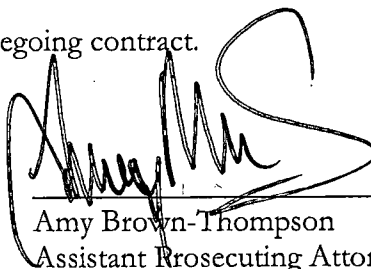

Amy Brown-Thompson
Assistant Prosecuting Attorney.

Date: 4/29/24

Signature Page

Resolution No. 2024-05.07.j

A Resolution to Approve the Contract with Asphalt Materials, Inc. for the Purchase of Liquid Asphalt

(Fairfield County Engineer)

This resolution has not yet been voted on.

CERTIFICATE OF CLERK

It is hereby certified that the foregoing is a true and correct transcript of a resolution acted upon by the Board of County Commissioners, Fairfield County, Ohio on the date noted above.

A resolution to request for appropriations for additional unanticipated receipts of memo receipts and memo expenses for fund 2050 for annual inspections in various subdivisions as of 04/29/2024.

WHEREAS, The Fairfield County Engineer has been expending funds from the Motor Vehicle fund for administrative costs attributable to the drainage repairs; and

WHEREAS, The Drainage Maintenance fund has received funds from the assessments to cover these administrative costs which have been deposited into the drainage maintenance fund as required; and

WHEREAS, it is necessary for the Motor Vehicle fund to recover the costs of these administrative and supply expenses from the drainage maintenance fund; and

NOW THEREFORE, BE IT RESOLVED BY THE BOARD OF COUNTY COMMISSIONERS, COUNTY OF FAIRFIELD, STATE OF OHIO:

Section 1. Request that the Fairfield County Board of Commissioner Appropriate from Unappropriated funds in the amount of \$5,742.12 into the following category:

\$316.95	30205700-Contractual Services
\$211.30	30245000-Contractual Services
\$216.80	30249600-Contractual Services
\$211.30	30249700-Contractual Services
\$200.30	30251900-Contractual Services
\$316.95	30260500-Contractual Services
\$222.30	30261500-Contractual Services
\$116.65	30265900-Contractual Services
\$528.26	30281000-Contractual Services
\$305.95	30281700-Contractual Services
\$211.30	30281900-Contractual Services
\$58.09	30282500-Contractual Services
\$528.26	30282700-Contractual Services
\$211.30	30282900-Contractual Services
\$633.91	30283000-Contractual Services
\$211.30	30283200-Contractual Services

A resolution to request for appropriations for additional unanticipated receipts of memo receipts and memo expenses for fund 2050 for annual inspections in various subdivisions as of 04/29/2024.

\$58.09	30283600-Contractual Services
\$287.25	30283700-Contractual Services
\$589.91	30284200-Contractual Services
\$305.95	30284700-Contractual Services

Section 2. The County Commissioners approve the following expenditure and request the Fairfield County Auditor accomplish the transaction by making the following memo expenditure, impacting appropriation as if a regular County Auditor warrant, reimbursing the Motor Vehicle fund for administrative and supply expenses incurred.

Memo Receipt as reference:

16202401-434000 \$5,742.12

Memo Expenditure as referenced:

Vendor: Fairfield County Engineer's Office
Amount: \$5,742.12
Paid: 04/29/2024

\$316.95	30205700-543000
\$211.30	30245000-543000
\$216.80	30249600-543000
\$211.30	30249700-543000
\$200.30	30251900-543000
\$316.95	30260500-543000
\$222.30	30261500-543000
\$116.65	30265900-543000
\$528.26	30281000-543000
\$305.95	30281700-543000
\$211.30	30281900-543000
\$58.09	30282500-543000
\$528.26	30282700-543000
\$211.30	30282900-543000
\$633.91	30283000-543000

A resolution to request for appropriations for additional unanticipated receipts of memo receipts and memo expenses for fund 2050 for annual inspections in various subdivisions as of 04/29/2024.

\$211.30	30283200-543000
\$58.09	30283600-543000
\$287.25	30283700-543000
\$589.91	30284200-543000
\$305.95	30284700-543000

**For Auditor's Office Use Only:
Section 1.**

\$316.95	30205700-543000
\$211.30	30245000-543000
\$216.80	30249600-543000
\$211.30	30249700-543000
\$200.30	30251900-543000
\$316.95	30260500-543000
\$222.30	30261500-543000
\$116.65	30265900-543000
\$528.26	30281000-543000
\$305.95	30281700-543000
\$211.30	30281900-543000
\$58.09	30282500-543000
\$528.26	30282700-543000
\$211.30	30282900-543000
\$633.91	30283000-543000
\$211.30	30283200-543000
\$58.09	30283600-543000
\$287.25	30283700-543000
\$589.91	30284200-543000
\$305.95	30284700-543000

Section 2. Issue an Amended Certificate in the amount of \$5,742.12 to credit of fund 2024

2024-05.07.k

A resolution to request for appropriations for additional unanticipated receipts of memo receipts and memo expenses for fund 2050 for annual inspections in various subdivisions as of 04/29/2024.

Section 3. Request that the Fairfield County Auditor, on behalf of the Budget Commission, update receipt line 16202401-434000 in the amount of \$5,742.12

Prepared by: Julie Huggins
cc: Engineer

Signature Page

Resolution No. 2024-05.07.k

A resolution to request for appropriations for additional unanticipated receipts of Memo receipts and memo expenses for fund 2050 for annual inspections in various subdivisions as of 04/29/2024.

(Fairfield County Engineer)

This resolution has not yet been voted on.

CERTIFICATE OF CLERK

It is hereby certified that the foregoing is a true and correct transcript of a resolution acted upon by the Board of County Commissioners, Fairfield County, Ohio on the date noted above.

A resolution to request for appropriations for additional unanticipated receipts of memo receipts and memo expenses for fund 3445 BLO-36 bridge replacement

WHEREAS, unanticipated revenue has been collected for Fund 3445; and

WHEREAS, unanticipated funds represent ODOT payment; and

WHEREAS, monies will be used for PID #117326 BLO-36

NOW THEREFORE, BE IT RESOLVED BY THE BOARD OF COUNTY COMMISSIONERS, COUNTY OF FAIRFIELD, STATE OF OHIO:

SECTION 1: Request that the Fairfield County Auditor appropriate from unappropriated funds in the amount of: \$8,040.00 16344506 Contractual Services.

SECTION 2: The County Commissioners approve the following expenditure and request the Fairfield County Auditor accomplish the transaction by making the following memo expenditure, impacting appropriation as if a regular County Auditor warrant,

Memo Receipt as referenced:

16344506-433100-75171

Memo Expenditure as referenced:

Vendor: SCP Upper Scioto LLC

Account #: 16344506-530020-75171 **BLO-36**

Amount: \$8,040.00 Paid: 05/02/2024

For Auditor's Office Use Only:

SECTION 1: 16344506-530020-75171

SECTION 3: Issue an Amended Certificate in the amount \$8,040.00 to credit of fund 3445.

SECTION 4: Request that the Fairfield County Auditor, on behalf of the Budget Commission, update receipt line 16344506-433100-75171 in the amount of \$8,040.00.

Prepared by: Julie Huggins
cc: Engineer Office

- REPORTS: ←
- CONTRACTOR REPORTS
- APPLICATIONS:
- BID & ITEM DATA
- ADDITIONAL LINKS:
- CONSTRUCTION REFERENCE RESOURCE CENTER(CRRC)
 - DISTRICT CONSTRUCTION SHAREPOINT MAIN
 - GoFORMZ HOME TEAM SITE
 - AASHTOWARE PROJECT SITE



Ohio Department of Transportation
Capital Program Payments

Notice to ODOT's LPA Subrecipients and External Auditors – April 15, 2024

This payments report cannot be used as the sole source of information for determining Federal funds expenditures to be reported on the LPA's annual Schedule of Expenditures of Federal Awards (SEFA). The LPA and their external auditors are directed to follow [ODOT's LPA SEFA Reporting Guidance](#). This ODOT guidance document includes procedures for the LPA to follow to ensure accurate SEFA reporting to avoid potential audit findings.

This CMS payments report was originally designed for contractors to obtain payment verification. ODOT has determined that the source data is sufficient for that purpose; however, since the payments data in this report does not distinguish Federal, state, or local funds, the report cannot be used as a standalone source for verification of SEFA data.

Additionally, this report reflects all of ODOT's expenditures on the project and does not identify only those Federal expenditures to be reported by the LPA. Further, this report does not reflect any project payments made by the LPA that have not yet been reimbursed by ODOT.

For LPAs preparing a cash basis SEFA, the LPA can use the Warrant Date on this report to assign the ODOT payments to contractors to a fiscal year for the LPA's SEFA reporting. However, if ODOT is issuing a reimbursement payment to the LPA, then the LPA's check dates would be used to assign those payments to a fiscal year. The LPA's copies of invoices submitted to ODOT, and the ODOT-LPA Project Agreement should provide support for the Federal share of the project costs.

Most of ODOT's subrecipients of Federal Awards are subject to compliance with [Title 2 CFR Part 200 Uniform Administrative Requirements, Cost Principles, and Audit Requirements for Federal Awards](#). Accordingly, the subrecipient is responsible for maintaining accurate financial records to demonstrate compliance with the requirements documented in [§ 200.302 Financial management](#).

The subrecipient's fiscal procedures and financial records must provide for tracking the project specific expenditure of Federal funds by the subrecipient. The subrecipient's financial records must accurately report, in the proper fiscal year, the Federal funds the subrecipient has expended, including those project expenditures which have not yet been reimbursed by ODOT and the Federal funds payments issued to contractors by ODOT as requested by the LPA.

ODOT's LPA SEFA Reporting Guidance and an Excel template for tracking Federal funds expenditures is available at: <https://www.transportation.ohio.gov/programs/external-audits/audit-lpa/guidance-lpa-sefa>
Please contact OEA-LPA-AUDITS@dot.ohio.gov with any questions regarding this notice.

BY PROCEEDING TO THE REPORT ON NEXT PAGE, YOU ARE ACKNOWLEDGING THIS DISCLAIMER.

Vendor Name/Number	Project Nbr	PID Nbr	Estimate Nbr	Process Date	Warrant Date	Amount
AMERICAN STRUCTUREPOINT INC (0000079127)		117326	PID#117326-5-171931	02/02/2024	02/08/2024	1,905.90
AMERICAN STRUCTUREPOINT INC (0000079127)		117326	PID#117326-4-160221	03/31/2023	04/06/2023	15,979.40
AMERICAN STRUCTUREPOINT INC (0000079127)		117326	PID#117326-3-157742	01/27/2023	02/02/2023	17,022.30
AMERICAN STRUCTUREPOINT INC (0000079127)		117326	PID#117326-2-157194	12/12/2022	12/16/2022	13,324.31
AMERICAN STRUCTUREPOINT INC (0000079127)		117326	PID#117326-1-155137	12/12/2022	12/16/2022	1,658.84
SCP UPPER SCIOTO, LLC (0000322357)		117326	PID#117326-1	04/26/2024	05/02/2024	8,040.00
Total Payment						57,930.75

Run Date 5/1/2024 12:13:20 PM

Page 1 of 1

Signature Page

Resolution No. 2024-05.07.I

A resolution to request for appropriations for additional unanticipated receipts of memo receipts and memo expenses for fund 3445 BLO-36 bridge replacement

(Fairfield County Engineer)

This resolution has not yet been voted on.

CERTIFICATE OF CLERK

It is hereby certified that the foregoing is a true and correct transcript of a resolution acted upon by the Board of County Commissioners, Fairfield County, Ohio on the date noted above.

A resolution to approve a reimbursement for REA/GIS services as a memo expenditure for fund 2024 – Motor Vehicle

WHEREAS, revenue has been collected for Fund 2022; and

WHEREAS, funds represent payment for REA/GIS services; and

WHEREAS, the County Auditor’s Office department of REA/GIS and the County Engineer has a verbal agreement for general GIS services

NOW THEREFORE, BE IT RESOLVED BY THE BOARD OF COUNTY COMMISSIONERS, COUNTY OF FAIRFIELD, STATE OF OHIO:

Section 1: That the Fairfield County Auditor reflect the following memo receipt:

10202200-434000 GISSUP \$44,000.00

This amount represents monies owed to the REA/GIS Department for FCEO’s share of REA/GIS services

Section 2: That the Fairfield County Board of Commissioners approves the following expenditures of other expenses and requests that the Fairfield County Auditor accomplish the transaction as if a regular County Auditor warrant reimbursing the REA/GIS Department for FCEO’s share of costs

Memo Expenditure as referenced:

Vendor: Fairfield County Auditor’s Office Department of REA/GIS
Account: 16202401-530208
Amount: \$44,000.00

Prepared by: Julie Huggins
cc: Dave Burgei

Signature Page

Resolution No. 2024-05.07.m

A resolution to approve a reimbursement for REA/GIS services as a memo expenditure for fund 2024 – Motor Vehicle

(Fairfield County Engineer)

This resolution has not yet been voted on.

CERTIFICATE OF CLERK

It is hereby certified that the foregoing is a true and correct transcript of a resolution acted upon by the Board of County Commissioners, Fairfield County, Ohio on the date noted above.

A Resolution to Approve the Notice to Commence for the 2024 Crack Sealing Project

WHEREAS, by Resolution on April 30, 2024, this Board of Commissioners awarded a Contract to Russell Standard Corporation; 639-B State Route 821; Marietta, OH 45750, in the amount of \$54,883.84 for the 2024 Crack Sealing Project.

WHEREAS, Section 1311, Ohio Revised Code requires the Public Authority to prepare a Notice of Commencement prior to commencement of performance, and

WHEREAS, the County Engineer is requesting the attached Notice be signed by the President of the Board of Commissioners.

NOW THEREFORE: BE IT RESOLVED BY THE BOARD OF COUNTY COMMISSIONERS, COUNTY OF FAIRFIELD, STATE OF OHIO:

SECTION 1: that this Board of Commissioners resolves to, and does hereby, authorize its President to sign the required Notice of Commencement in the matter of the 2024 Crack Sealing Project.

SECTION 2: that the Clerk of this Board furnish the County Engineer with a signed copy of the Recorded Resolution for further processing.

Prepared by: Randy Carter
cc: Engineering Department

NOTICE OF COMMENCEMENT
(Section 1311.04 and 1311.252, Ohio Revised Code)

STATE OF OHIO:

SS

COUNTY OF FAIRFIELD:

Now comes the Board of Commissioners of Fairfield County Ohio by Steven A. Davis, its President, who after being duly cautioned and sworn, states the following in connection with the 2024 Crack Sealing Project:

1. The Public Improvement under construction is the crack sealing of various county roads.
2. The name, address, and capacity of the Owner of the real property contracting for the improvement is the Board of Commissioners of Fairfield County Ohio; 210 East Main Street; Room 301; Lancaster, Ohio 43130-3879.
3. The name and address of the fee owner of said real property is the Board of Commissioners of Fairfield County Ohio; 210 East Main Street; Room 301; Lancaster, Ohio 43130-3879.
4. The name, address, and trade of the principal Contractor is: Russell Standard Corporation; 639-B State Route 821; Marietta, OH 45750, whose principal trade is that of road contractor.

This instrument was prepared by:
Amy Brown-Thompson, Assistant Prosecuting Attorney for Fairfield County Ohio; 239 W. Main Street; Suite 101; Lancaster, Ohio 43130.

5. The fee owner of said property has no designee.
6. The date the public authority first executed a contract with the principal Contractor for the public improvement was April 30, 2024.
7. There are currently no lending institutions providing financing for this improvement.
8. The name and address of the surety on the bond guaranteeing payment of the original Contractor's obligations under the contract for this improvement is Western Surety Company; 151 N. Franklin Street; Chicago, IL 60606.
9. To Lien Claimants and Subsequent Purchasers: Take notice that labor or work is about to begin on, or materials are about to be furnished for, an improvement to the real estate described in this instrument. A person having a mechanics' lien may preserve the lien by proving a Notice of Furnishing to the above-named designee and his original Contractor, if any, by timely recording an affidavit pursuant to Section 1311.06 of the Ohio Revised Code. A copy of this notice may be obtained upon making a written request by certified mail to the above-named owner, part owner, lessee, designee, or the person with whom you have contracted.
10. The name and address of the person preparing this notice is Amy Brown-Thompson, Assistant Prosecuting Attorney for Fairfield County Ohio; 239 W. Main Street; Suite 101; Lancaster, Ohio 43130.

2024-05.07.n

11. The foregoing information is true and accurate to the best of my knowledge and belief.

12. Further affiant sayeth naught.

David L Levacy
The Board of Commissioners of
Fairfield County Ohio, Affiant

Be it remembered, that on this _____ day of _____, 2024, before me, the subscriber, a notary public, in and for said state, personally came Steven A. Davis, President of the Board of Commissioners of Fairfield County Ohio, affiant in the foregoing Affidavit, who acknowledged that signing thereof to be his individual voluntary act and deed and the voluntary act and deed of the Board of Commissioners of Fairfield County Ohio.

In testimony thereof, I have hereunto subscribed my name and affixed my seal on this day and year aforesaid.

Notary Public – State of Ohio

This instrument was prepared by:
Amy Brown-Thompson, Assistant Prosecuting Attorney for Fairfield County Ohio; 239 W. Main Street; Suite 101; Lancaster, Ohio 43130.

Signature Page

Resolution No. 2024-05.07.n

A Resolution to Approve the Notice to Commence for the 2024 Crack Sealing Project
(Fairfield County Engineer)

This resolution has not yet been voted on.

CERTIFICATE OF CLERK

It is hereby certified that the foregoing is a true and correct transcript of a resolution acted upon by the Board of County Commissioners, Fairfield County, Ohio on the date noted above.

A Resolution to Approve the Notice to Commence for the Purchase of Liquid Asphalt

WHEREAS, by Resolution on April 16, 2024, this Board of Commissioners awarded a Contract to Asphalt Materials, Inc.; 13925 State Route 7; Marietta, OH 45750, in the amount of \$572,760.00 for the Purchase of Liquid Asphalt.

WHEREAS, Section 1311, Ohio Revised Code requires the Public Authority to prepare a Notice of Commencement prior to commencement of performance, and

WHEREAS, the County Engineer is requesting the attached Notice be signed by the President of the Board of Commissioners.

NOW THEREFORE: BE IT RESOLVED BY THE BOARD OF COUNTY COMMISSIONERS, COUNTY OF FAIRFIELD, STATE OF OHIO:

SECTION 1: that this Board of Commissioners resolves to, and does hereby, authorize its President to sign the required Notice of Commencement in the matter of the Purchase of Liquid Asphalt.

SECTION 2: that the Clerk of this Board furnish the County Engineer with a signed copy of the Recorded Resolution for further processing.

Prepared by: Randy Carter
cc: Engineering Department

NOTICE OF COMMENCEMENT
(Section 1311.04 and 1311.252, Ohio Revised Code)

STATE OF OHIO:

SS

COUNTY OF FAIRFIELD:

Now comes the Board of Commissioners of Fairfield County Ohio by Steven A. Davis, its President, who after being duly cautioned and sworn, states the following in connection with the Purchase of Liquid Asphalt:

1. The Public Improvement under construction is the purchase of liquid asphalt.
2. The name, address, and capacity of the Owner of the real property contracting for the improvement is the Board of Commissioners of Fairfield County Ohio; 210 East Main Street; Room 301; Lancaster, Ohio 43130-3879.
3. The name and address of the fee owner of said real property is the Board of Commissioners of Fairfield County Ohio; 210 East Main Street; Room 301; Lancaster, Ohio 43130-3879.
4. The name, address, and trade of the principal Contractor is: Asphalt Materials, Inc.; 13925 State Route 7; Marietta, OH 45750, whose principal trade is that of liquid asphalt supplier.

This instrument was prepared by:
Amy Brown-Thompson, Assistant Prosecuting Attorney for Fairfield County Ohio; 239 W. Main Street; Suite 101; Lancaster, Ohio 43130.

5. The fee owner of said property has no designee.
6. The date the public authority first executed a contract with the principal Contractor for the public improvement was April 16, 2024.
7. There are currently no lending institutions providing financing for this improvement.
8. The name and address of the surety on the bond guaranteeing payment of the original Contractor's obligations under the contract for this improvement is Continental Casualty Company; 151 N. Franklin Street; 17th Floor; Chicago, IL 60606.
9. To Lien Claimants and Subsequent Purchasers: Take notice that labor or work is about to begin on, or materials are about to be furnished for, an improvement to the real estate described in this instrument. A person having a mechanics' lien may preserve the lien by proving a Notice of Furnishing to the above-named designee and his original Contractor, if any, by timely recording an affidavit pursuant to Section 1311.06 of the Ohio Revised Code. A copy of this notice may be obtained upon making a written request by certified mail to the above-named owner, part owner, lessee, designee, or the person with whom you have contracted.
10. The name and address of the person preparing this notice is Amy Brown-Thompson, Assistant Prosecuting Attorney for Fairfield County Ohio; 239 W. Main Street; Suite 101; Lancaster, Ohio 43130.

11. The foregoing information is true and accurate to the best of my knowledge and belief.

12. Further affiant sayeth naught.

Dave Levacy
The Board of Commissioners of
Fairfield County Ohio, Affiant

Be it remembered, that on this _____ day of _____, 2024, before me, the subscriber, a notary public, in and for said state, personally came Dave Levacy, President of the Board of Commissioners of Fairfield County Ohio, affiant in the foregoing Affidavit, who acknowledged that signing thereof to be his individual voluntary act and deed and the voluntary act and deed of the Board of Commissioners of Fairfield County Ohio.

In testimony thereof, I have hereunto subscribed my name and affixed my seal on this day and year aforesaid.

Notary Public – State of Ohio

Signature Page

Resolution No. 2024-05.07.o

A Resolution to Approve the Notice to Commence for the Purchase of Liquid Asphalt
(Fairfield County Engineer)

This resolution has not yet been voted on.

CERTIFICATE OF CLERK

It is hereby certified that the foregoing is a true and correct transcript of a resolution acted upon by the Board of County Commissioners, Fairfield County, Ohio on the date noted above.

A resolution to approve a memo exp./ memo receipt for the costs of Birth Certificates paid to Fairfield County Health Departments as a memo expenditure for fund# 2072 Public Children's Services

WHEREAS, FCJFS is responsible for paying the Health Department for their Birth Certificate costs; and

NOW THEREFORE, BE IT RESOLVED BY THE BOARD OF COUNTY COMMISSIONERS, COUNTY OF FAIRFIELD, STATE OF OHIO:

Section 1: That the Fairfield County Auditor reflect the following memo receipt:

71700300- 434410 Reimbursement - \$192.00

This amount represents monies owed to the Health Department for FCJFS's costs paid to the Health Department as denoted in the attached documentation.

Section 2: That the Fairfield County Board of Commissioners approves the following expenditure of other expenses and requests that the Fairfield County Auditor accomplish the transaction as if a regular County Auditor warrant reimbursing the Health Department for FCJFS's Birth Certificate costs.

Memo expenditure as referenced in supporting documentation:

Vendor # 7482 Fairfield County Health Department

Account: 12207207-533000 Other Professional Services

Amount: \$192.00

Prepared by: Morgan Fox, Fiscal Officer

cc: Jamie Ehorn, Fairfield County Health Department

Signature Page

Resolution No. 2024-05.07.p

A resolution to approve a memo exp./ memo receipt for the costs of Birth Certificates paid to Fairfield County Health Departments as a memo expenditure for fund# 2072 Public Children's Services

(Fairfield County Job and Family Services)

This resolution has not yet been voted on.

CERTIFICATE OF CLERK

It is hereby certified that the foregoing is a true and correct transcript of a resolution acted upon by the Board of County Commissioners, Fairfield County, Ohio on the date noted above.

A resolution regarding a Purchase of Services Contract between TeenWorks and Job & Family Services

WHEREAS, Fairfield County Job & Family Services (FCJFS) is requesting the Board of Commissioners approval of a purchase of service contract with Fairfield County TeenWorks 2590 Kull Road Lancaster, Ohio 43130, and

WHEREAS, the purpose of the purchase of service contract is to provide a Summer Youth Employment Program to TANF eligible participants, and

WHEREAS, this agreement shall be effective May 15th, 2024 through September 30th, 2024, and

WHEREAS, the Prosecuting Attorney has approved the agreement as to form,

NOW THEREFORE, BE IT RESOLVED BY THE BOARD OF COUNTY COMMISSIONERS, COUNTY OF FAIRFIELD, AND STATE OF OHIO:

Section 1. That the Fairfield County Board of Commissioners hereby approves the attached agreement with Fairfield County TeenWorks and Fairfield County Job & Family Services.

Prepared by: Brandi Downhour
cc: JFS / Budget Manager



Office of Auditor of State
88 East Broad Street
Post Office Box 1140
Columbus, OH 43216-1140

Auditor of State - Unresolved Findings for Recovery Certified Search

(614) 466-4514
(800) 282-0370

I have searched The Auditor of State's unresolved findings for recovery database using the following criteria:

Contractor's Information:

Name: ,
Organization: **Teenworks**
Date: **4/30/2024 10:53:09 AM**

This search produced the following list of **1** possible matches:

Name/Organization	Address
Harrison County Democratic Executive Committee	80900 Slab Camp Road

The above list represents possible matches for the search criteria you entered. Please note that pursuant to ORC 9.24, only the person (which includes an organization) actually named in the finding for recovery is prohibited from being awarded a contract.

If the person you are searching for appears on this list, it means that the person has one or more findings for recovery and is prohibited from being awarded a contract described in ORC 9.24, unless one of the exceptions in that section apply.

If the person you are searching for does not appear on this list, an initialed copy of this page can serve as documentation of your compliance with ORC 9.24(E).

Please note that pursuant to ORC 9.24, it is the responsibility of the public office to verify that a person to whom it plans to award a contract does not appear in the Auditor of State's database. The Auditor of State's office is not responsible for inaccurate search results caused by user error or other circumstances beyond the Auditor of State's control.

Cost Analysis

Cost shall not exceed \$150,000.00 for the 2024 TANF Summer Youth Program.

ROUTING FORM FOR CONTRACTS

The undersigned designee of the County affirms that he/she has reviewed the attached contract to ensure that it complies with County's needs and previous negotiations. The undersigned designee further affirms that the County has complied with the competitive selection process, as prescribed by the Ohio Revised Code, by selecting one of the boxes below.

- A. Goods and/or Services in excess of \$50,000.00—competitively selected via an Invitation to Bid, pursuant to R.C. 307.86-307.92
- B. Goods and/or Services in excess of \$50,000.00—competitively selected via a Request for Proposals, pursuant to R.C. 307.862
- C. Public Improvement contracts—competitively selected pursuant to R.C. 153.08-153.12
- D. Architect/Engineer design services for public improvements—selected through the Request for Qualifications process pursuant to R.C. 153.65-153.72
- E. County Road Improvement/Construction—competitively selected pursuant to R.C. 5555.61
- F. The subject matter was exempt from competitive selection for the following reason(s):
 - 1. Under \$50,000
 - 2. State Term #: _____ (copy of State Term Contract must be attached)
 - 3. ODOT Term #: _____ (See R.C. 5513.01)
 - 4. Professional Services (See R.C. 307.86)
 - 5. Emergency (Follow procedure under ORC 307.86(A))
 - 6. Sole Source (attach documentation as to why contract is sole source)
 - 7. Other: _____ (cite to authority or explain why matter is exempt from competitive bidding)
- G. Agreement not subject to Sections A-F (explain): _____
- H. Compliance with Fairfield County Board of Commissioners Procurement Guidelines
 - 1. No County employee, employee's family member, or employee's business associate has an interest in this contract OR such interest has been disclosed and reviewed by the Prosecutor's Office
 - 2. No Finding for Recovery against Vendor as required under R.C. 9.24 (search via "Certified Search" on <http://ffr.ohioauditor.gov/>)
 - 3. Obtained 3 quotes for purchases under \$50,000
 - 4. Purchase Order is included with Agreement

Signed this _____ day of _____, 20_____.

Name and Title  Fiscal Officer

*** Please note that this checklist only addresses County and statutory requirements. If a contract is paid for with state and/or federal funds, please consult with the appropriate state and/or federal agency to ensure your department is complying with any additional requirements. By submitting a request for approval, you are certifying you have addressed County, statutory, and grant requirements.***



Important Reqs and Certs Update [Show Details](#)

Mar 1, 2024



[See All Alerts](#)

Entity Validation Processing [Show Details](#)

Apr 23, 2024



[Home](#) [Search](#) [Data Bank](#) [Data Services](#) [Help](#)

Search

All Words

e.g. 1606N020Q02

Select Domain

All Domains



Filter By





Keyword Search

For more information on how to use our keyword search, visit our [help guide](#)

Simple Search

Search Editor

Any Words 

All Words 

Exact Phrase 

e.g. 1606N020Q02

teenworks 

Federal Organizations

Enter Code or Name 



Status 

Active

Inactive

Reset 



No matches found

Your search did not return any results.

To view Entity Registrations, you must sign in.

[Sign In](#)

Would you like to include inactive records in your search results?

[Yes](#)

[Go Back](#)



Feedback

Our Website

[About This Site](#)

[Our Community](#)

[Release Notes](#)

[System Alerts](#)

Policies

[Terms of Use](#)

[Privacy Policy](#)

[Restricted Data Use](#)

[Freedom of Information Act](#)

[Accessibility](#)

Our Partners

[Acquisition.gov](#)

[USASpending.gov](#)

[Grants.gov](#)

[More Partners](#)

Customer Service

[Help](#)

[Check Entity Status](#)

[Federal Service Desk](#)

[External Resources](#)

[Contact](#)



⚠ WARNING

This is a U.S. General Services Administration Federal Government computer system that is **"FOR OFFICIAL USE ONLY!"** This system is subject to monitoring. Individuals found performing unauthorized activities are subject to disciplinary action including criminal prosecution.

This system contains Controlled Unclassified Information (CUI). All individuals viewing, reproducing or disposing of this information are required to protect it in accordance with 32 CFR Part 2002 and GSA Order CIO 2103.2 CUI Policy.

SAM.gov

An official website of the U.S. General Services Administration

**Purchase of Service Contract
Fairfield County Job & Family Services
and
Fairfield County TeenWorks**

This contract is made and entered into this 1st day of May 2024, by and between Fairfield County Job and Family Services (FCJFS) and Fairfield County TeenWorks, 4465 Coonpath Road NW, Carroll, OH 43112.

- 1) **Purchase of Service(s):** Subject to terms and conditions set forth in this contract, FCJFS agrees to purchase from, and provider agrees to furnish to FCJFS those specific services detailed in this contract with Fairfield County TeenWorks. The vendor will provide TANF Summer Youth Employment to FCJFS as specified within this purchase of service contract.
- 2) **Purpose of Contract:** The purpose of this contract is to implement a TANF Summer Youth Employment Program, representing TANF eligible participants from the age of 14-18. FCJFS agrees to purchase, and provider agrees to furnish all appropriate payroll services, to cover participants under workers' compensation and liability insurances, and to coordinate reporting activities with FCJFS as needed for the TANF Summer Youth Program.
- 3) **Contract Period:** This contract shall be effective from May 1st, 2024 through September 30, 2024. The contract services shall not exceed \$68,713.00.
- 4) **Reporting Requirements:** The vendor will be responsible for monthly reporting of information about participants, including individual data such as program begin date, program end date, age, employer, type of employment, reason for leaving, salary, average hours per week; and specialized skills gained. Also, a pre- and post-employment competencies inventory will be required for all participating youth.
- 5) **Certificate of Completion:** Fairfield County TeenWorks is required to issue to the participating youth who completed the summer youth program a Certificate of Completion. Youth who left the program before completion will not be eligible for a certificate. The design of the certificate will be left up to Fairfield County TeenWorks. The certificate shall contain, at a minimum, the following items:
 - The name of the program (TANF Summer Youth Employment Program);
 - The name of the youth;
 - The dates of participation; and

- The name of the employer.
 - Upon the completion of the program, Fairfield County TeenWorks will provide a copy of each certificate to FCJFS.
- 6) **Participant Work Permits:** Fairfield County TeenWorks must ensure they will be responsible for obtaining work permits for all participants as identified by the Ohio Minor Labor Law and will provide FCJFS a copy of such document for each participant.
- 7) **Allowable Costs:** Allowable costs under this program include:
- Payments to employers for wages (at no higher than \$13.00 per hour) and fringe benefits;
 - Payments to third parties to operate the program;
 - Recruitment and development of employers for the program;
 - Other ancillary services which are offered by the employer to the summer youth employment participants, including:
 - Work related items such as uniforms, tools, licenses or certifications;
 - Case management activities related to the program; and
 - Job coaches and mentors.
 - Worker compensation expenses;
 - FICA;
 - Direct supervision and training costs; and
 - Transportation costs to and from the work site.
- 8) **Invoicing:** Fairfield County TeenWorks shall submit a complete and accurate invoice to FCJFS for services provided. FCJFS will review all invoices for accuracy before making payment. Fairfield County TeenWorks will provide sufficient detail to demonstrate amounts paid to the TANF Summer Youth participants. FCJFS will remit payment within 30 days of receiving a complete and accurate invoice from Fairfield County TeenWorks.
- 9) **Confidentiality:** The provider agrees to comply with all federal and state laws applicable to FCJFS and/or customers of FCJFS concerning confidentiality of FCJFS customers. Provider agrees that the use or disclosure of information concerning FCJFS customers for any purpose is prohibited.
- 10) **Equal Employment Opportunity:** The provider shall comply with Executive Order 11246, "Equal Employment Opportunity" as amended by Executive Order 11375 and supplemented by Department of Labor Regulations.
- 11) **Child Support Enforcement:** Provider agrees to cooperate with the FCJFS and any Child Support Enforcement Agency (CSEA) in ensuring employees of the provider and/or

subcontractor(s) met child support obligations established under state law. Further, by executing this contract, provider certifies present and future compliance with any court order for the withholding of support, which is issued pursuant to all sections of 3121 of the Ohio Revised Code.

- 12) **Termination:** This contract may be amended at any time by written instrument, agreed to, and signed by all parties. Either party FCJFS, or the provider, Fairfield County TeenWorks, upon thirty (30) days written notice given by either party to the other may terminate this contract.
- 13) **Conflict of Interest:** Provider agrees that it will not permit funds to be paid or committed to be paid to any corporation, firm, association, or business in which any of the members of the governing body of the agency, executive personnel, or their immediate families have any direct or indirect financial interest, or in which any of these persons serve as an officer or employee: unless the services or goods involved are provided at a competitive cost and under terms favorable to the provider. The provider shall make written disclosure of any and all financial transactions of the provider in which a member of the board or his/her immediate family is involved. Provider agrees to the requirements of rule as applicable in the Ohio Administrative Code.
- 14) **Evaluation and Monitoring:** FCJFS, with cooperation of the provider will complete periodic monitoring and review activities as deemed necessary by FCJFS to ensure compliance with the terms of the contract. The continuation of the contract shall be contingent upon the achievement of the objectives contained in the contract.
- 15) **Violation or Breach of Contract Terms:** The provider shall not be relieved of liability to FCJFS for damages sustained by FCJFS by virtue of any breach of the contract by the provider. FCJFS reserves the right to legal, administrative, and contractual remedies for damages sustained by FCJFS by virtue of any breach of the contract by the provider. FCJFS may withhold any compensation from the provider until the amount of damages due FCJFS from the provider is agreed upon or otherwise terminated.
- 16) **Civil Rights:** The provider agrees that there shall be no discrimination against any customer or any employee because of race, color, sex, religion, disability, national origin, or any other factor as specified in Title VI of the Civil Rights Act of 1964, Rehabilitation Act of 1973 and subsequent amendments. It is further agreed that the vendor will comply with all appropriate federal and state laws regarding such discrimination.

17) **Compliance Requirements:** The provider shall perform its obligations under this contract in conformity with all applicable local, state and federal rules, laws and regulations. They include but are not limited to the following, when applicable:

- a) Clean Air Act: requiring compliance with applicable standards, orders, or requirements issued under Section 306 of the Clean Air Act 42 USC 1857(h) Section 508 of the Clean Water Act 33 USC 1368, Executive Order 11738, and Environmental Protection Agency regulations 40 CFR Part 15.
- b) Debarment and Suspension: requiring compliance with Executive Orders 12549 and 12689.
- c) Lobbying: requiring compliance for anti-lobbying provisions of 31 USC 1352.
- d) Anti-Kickback Act: requiring compliance with the Copeland Anti-Kickback Act 18 USC 874 as supplemented in Department of Labor regulations 29 CFR Part 3.
- e) Contract Work Hours and Safety Standard Act: requiring compliance with the Contract Work Hours and Safety Standards Act 40 USC 327-330 as supplemented by Department of Labor regulations 29 CFR Part 5.
- f) Davis-Bacon Act: requiring compliance with Davis-Bacon Act, 40 USC 276 and 327 to 330 as supplemented by Department of Labor regulations at 29 CFR Part 5.
- g) Energy Policy and Conservation Act: requiring compliance with the Energy Policy and Conservation Act (PL94-165).

18) **Drug Free Workplace:** The parties hereto agree to comply with all applicable federal and state laws regarding drug-free workplace. The parties further agree that they will make good faith effort to ensure that all employees of a government or private entity performing duties or responsibilities under this agreement shall not use illegal or abuse alcohol or prescription drugs in any way.

19) **Pro-Children Act:** In the event that the Provider activities call for services to minor, the Provider shall comply with the Pro-children Act of 1994: Public Law 1-3-277, Part C environment Tobacco Smoke which requires that smoking not be permitted in any portion of any indoor facility owned or leased or contracted by an entity and used routinely or regularly for the provision or health care services, day care, library services and education to children under the age of 18.

20) **Indemnity:** The provider will indemnify and hold harmless Fairfield County Job and Family Services against any loss, penalties, damage, settlements, costs, professional fees, and/or related expense incurred through the provision of services under this contract.

21) **Retention of Records:** Fairfield County TeenWorks shall retain and make available for audit by Fairfield County Job and Family Services, the State of Ohio (including, but not

limited to, Ohio Department of Job and Family Services, the Auditor of State of Ohio, Inspector General, or duly appointed law enforcement officials), and agencies of the United States government all records relating to the service provided under this agreement and supporting documentation for invoices submitted to Fairfield County Job and Family Services by Fairfield County TeenWorks for so long as any of the above entities has the right to audit the books and records of FCJFS which, in all events should be no less than a minimum of three (3) years after payment under this agreement. If an audit begins during this period, Fairfield County TeenWorks shall retain such records until the conclusion of the audit and resolution of all related issues.

Fairfield County Job & Family Services
and
Fairfield County TeenWorks

Corey B. Clark, Director
Fairfield County Job and Family Services

Date

Jodi C. Smith

4/26/2024

Jodi C. Smith, Operations Manager, CCMEP
Fairfield County Job and Family Services

Date

Angela Harris

4/25/24

Angela Harris, Executive Director
Fairfield County TeenWorks

Date

Fairfield County Assistant Prosecuting Attorney
approved as to form

Date

Approved by resolution by the Fairfield County Board of Commissioners

JFS Mission Statement- *To protect children and elderly, encourage family stability, and promote self-reliance for a stronger community.*

Fairfield County TeenWorks TANF 2024-2025



**A Contract regarding TANF Summer Youth between Job and Family Services
and**

Approved on 4/26/2024 1:33:23 PM by Jodi Smith, Operations Manager

Jodi Smith
Operations Manager

Approved on 4/26/2024 2:29:55 PM by Corey Clark, Director of Fairfield County
Job & Family Services

Corey Clark, Director
Fairfield County Job & Family Services

Prosecutor's Approval Page

Resolution No.

A resolution regarding a Purchase of Services Contract between TeenWorks and Job & Family Services

(Fairfield County Job and Family Services)

Approved as to form on 5/2/2024 4:13:52 PM by Amy Brown-Thompson,



Amy Brown-Thompson
Prosecutor's Office
Fairfield County, Ohio

Signature Page

Resolution No. 2024-05.07.q

A Resolution Regarding a Purchase of Services Contract between TeenWorks and
Job & Family Services

(Fairfield County Job and Family Services)

This resolution has not yet been voted on.

CERTIFICATE OF CLERK

It is hereby certified that the foregoing is a true and correct transcript of a resolution acted upon by the Board of County Commissioners, Fairfield County, Ohio on the date noted above.

A resolution to approve an award of bid to Spires Paving Company for the CDBG - PY2022 - Village of Pleasantville Hickenlooper Street Improvement project. [Regional Planning]

WHEREAS, Fairfield County has received a CDBG grant for PY2022;

WHEREAS, The Village of Pleasantville has requested that improvements be made to Hickenlooper Street; and

WHEREAS, a bid opening was held on Friday, April 26th, 2024 at 11:00 a.m. with an engineer’s estimate of \$46,200.00 the following bids were received:

Spires Paving Company	\$36,620.00 (as submitted)
McKee Paving and Sealing, LLC.	\$43,400.00
Dreams Excavating and Paving LLP	\$45,735.00
The Shelly Company	\$53,356.00
Chemcote INC.	\$56,120.00

WHEREAS, bids have been reviewed and evaluated by Verdantas and recommends awarding the bid to Spires Paving Company for the amount of \$36,470.00 (per Verdantas Bid Tab).

NOW THEREFORE, BE IT RESOLVED BY THE BOARD OF COUNTY COMMISSIONERS, COUNTY OF FAIRFIELD, STATE OF OHIO:

Section 1. That the Board of Commissioners hereby approves the attached Notice of Award to Spires Paving Company for the CDBG - PY2022 - Village of Pleasantville Hickenlooper Street Improvement Project.

Section 2. That the Budget Officer of the Board of Commissioners requests a purchase order in the amount of \$36,470.00 (per Verdantas Bid Tab) to Spires Paving Company 1480 Sugar Grove Road SE, Lancaster, Ohio. 43130.

Prepared by: Joshua Hillberry
cc: Regional Planning

NOTICE OF AWARD

To: _____

PROJECT Description: Fairfield County – CDBG – Village of Pleasantville - Hickenlooper Street Improvements

The OWNER has considered the BID submitted by you on _____ for the above described WORK in response to its Advertisement for BIDS and Information for BIDDERS.

You are hereby notified that your BID has been accepted for items in the amount of \$_____.

You are required by the Information for BIDDERS to execute the Agreement and furnish the required CONTRACTOR's Contract BOND, if applicable, and Certificates of Insurance within 10 calendar days from the date of this notice to you.

If you fail to execute said Agreement and to furnish said BOND within 10 days from the date of this notice, said OWNER will be entitled to consider all your rights arising out of the OWNER's acceptance of your BID as abandoned and as a forfeiture of your BID guaranty subject to the liability as set forth in Section 153.54 of the Ohio Revised Code. The OWNER will be entitled to such other rights as may be granted by law.

You are required to return an acknowledged copy of this NOTICE OF AWARD to the OWNER.

Dated this ____ day of _____, 2024.

FAIRFIELD COUNTY COMMISSIONERS
Owner

By: _____
Title: President

ACCEPTANCE OF NOTICE

Receipt of the above NOTICE OF AWARD is hereby acknowledged by _____
_____ on this day of _____, 2024

By: _____
Name and Title: _____



April 30, 2024

Fairfield County Regional Planning Commission
Joshua Hillberry, Regional Planner
138 West Chestnut Street
Lancaster, Ohio 43130

Re: Village of Pleasantville – Hickenlooper Street Improvements
Bid Award Recommendation

Dear Mr. Hillberry,

Verdantas has reviewed the bids submitted on April 26, 2024 for the Village of Pleasantville – Hickenlooper Street Improvements project. The following is a summary of the bids submitted followed by our recommendation for award:

<u>Contractor</u>	<u>Base Bid</u>
Spires Paving Company	\$36,470.00
Mckee Paving and Sealing, LLC	\$43,400.00
Dreams Excavating and Paving LLP	\$45,735.00
The Shelly Company	\$53,356.00
Chemcote Inc.	\$56,119.80

Verdantas has checked the bids for mathematical errors and prepared a bid tabulation (see attached). Five bids were received, and three bids were under the engineer's base bid estimate of \$46,200.00. Spires Paving Company is the apparent low bidder and the required forms were included in their bid package. Verdantas has worked with Spires Paving Company in the past including a few projects in the Village of Pleasantville. All of those projects were completed satisfactorily. Based on the information provided in their bid and previous experience with the Contractor, we recommend that the project be awarded in the amount of **\$36,470.00** to:

Spires Paving Company
1480 Sugar Grove Road SE
Lancaster, Ohio 43130

Considering this volatile bidding environment, we are pleased with the results of the bid opening and hope the County and Village are as well. Please feel free to contact our office with any questions or concerns.

Sincerely,
Verdantas LLC

Alan Brown, PE
AVP/ Department Leader

Attachment: Bid Tabulation

**FAIRFIELD COUNTY COMMISSIONERS
VILLAGE OF PLEASANTVILLE
HICKENLOOPER STREET IMPROVEMENTS
BID TABULATION
BASE BID ESTIMATE: \$46,200.00**

Line No.	Description	Quantity	Unit	1. Spires Paving Company				2. Mckee Paving and Sealing, LLC				3. Dreams Excavating and Paving LLP				
				Unit Price			Extended Price	Unit Price			Extended Price	Unit Price			Extended Price	
				Labor	Materials	Total (L+M)	(Quantity x Total)	Labor	Materials	Total (L+M)	(Quantity x Total)	Labor	Materials	Total (L+M)	(Quantity x Total)	
1	MOBILIZATION / DEMOBILIZATION	1	LS	\$ 2,500.00	\$ -	\$ 2,500.00	\$ 2,500.00	\$ 2,000.00	\$ -	\$ 2,000.00	\$ 2,000.00	\$ 4,000.00	\$ -	\$ 4,000.00	\$ 4,000.00	
2	PARTIAL DEPTH PAVEMENT REPAIR, PER PLAN	20	CY	\$ 100.00	\$ 150.00	\$ 250.00	\$ 5,000.00	\$ 340.00	\$ 160.00	\$ 500.00	\$ 10,000.00	\$ 508.00	\$ 162.00	\$ 670.00	\$ 13,400.00	
3	FULL DEPTH PAVEMENT REPAIR, PER PLAN	15	SY	\$ 67.00	\$ 20.00	\$ 87.00	\$ 1,305.00	\$ 50.00	\$ 20.00	\$ 70.00	\$ 1,050.00	\$ 42.93	\$ 21.07	\$ 64.00	\$ 960.00	
4	ASPHALT CONCRETE SURFACE COURSE (1.75" THICK), PER PLAN	50	CY	\$ 260.00	\$ 165.00	\$ 425.00	\$ 21,250.00	\$ 218.00	\$ 160.00	\$ 378.00	\$ 18,900.00	\$ 170.00	\$ 158.00	\$ 328.00	\$ 16,400.00	
5	NON-TRACKING TACK COAT, PER PLAN	1	LS	\$ 525.00	\$ 290.00	\$ 815.00	\$ 815.00	\$ 260.00	\$ 450.00	\$ 710.00	\$ 710.00	\$ 75.00	\$ 900.00	\$ 975.00	\$ 975.00	
6	COMPACTED BERM, COMPLETE	20	CY	\$ 50.00	\$ 60.00	\$ 110.00	\$ 2,200.00	\$ 237.00	\$ 50.00	\$ 287.00	\$ 5,740.00	\$ 170.00	\$ 70.00	\$ 240.00	\$ 4,800.00	
7	MAINTENANCE AND PROTECTION OF TRAFFIC	1	LS	\$ 500.00	\$ 500.00	\$ 1,000.00	\$ 1,000.00	\$ 2,000.00	\$ -	\$ 2,000.00	\$ 2,000.00	\$ 2,500.00	\$ -	\$ 2,500.00	\$ 2,500.00	
8	PAVEMENT MARKINGS, COMPLETE	1	LS	\$ 1,200.00	\$ 1,200.00	\$ 2,400.00	\$ 2,400.00	\$ 2,000.00	\$ 1,000.00	\$ 3,000.00	\$ 3,000.00	\$ 2,700.00	\$ -	\$ 2,700.00	\$ 2,700.00	
TOTAL BASE BID (sum lines 1:8)							\$ 36,470.00					\$ 43,400.00				

Original Bid \$36,620.00

Line No.	Description	Quantity	Unit	4. The Shelly Company				5 Chemcote Inc.				
				Unit Price			Extended Price	Unit Price			Extended Price	
				Labor	Materials	Total (L+M)	(Quantity x Total)	Labor	Materials	Total (L+M)	(Quantity x Total)	
1	MOBILIZATION / DEMOBILIZATION	1	LS	\$ 3,750.00	\$ 1,250.00	\$ 5,000.00	\$ 5,000.00	\$ 1,040.00	\$ 1,560.00	\$ 2,600.00	\$ 2,600.00	
2	PARTIAL DEPTH PAVEMENT REPAIR, PER PLAN	20	CY	\$ 280.00	\$ 425.00	\$ 705.00	\$ 14,100.00	\$ 179.15	\$ 348.15	\$ 527.30	\$ 10,546.00	
3	FULL DEPTH PAVEMENT REPAIR, PER PLAN	15	SY	\$ 130.00	\$ 195.00	\$ 325.00	\$ 4,875.00	\$ 435.46	\$ 991.26	\$ 1,426.72	\$ 21,400.80	
4	ASPHALT CONCRETE SURFACE COURSE (1.75" THICK), PER PLAN	50	CY	\$ 193.00	\$ 170.00	\$ 363.00	\$ 18,150.00	\$ 112.00	\$ 168.00	\$ 280.00	\$ 14,000.00	
5	NON-TRACKING TACK COAT, PER PLAN	1	LS	\$ -	\$ 555.00	\$ 555.00	\$ 555.00	\$ 360.00	\$ 40.00	\$ 400.00	\$ 400.00	
6	COMPACTED BERM, COMPLETE	20	CY	\$ 90.00	\$ 50.00	\$ 140.00	\$ 2,800.00	\$ 157.50	\$ 24.30	\$ 181.80	\$ 3,636.00	
7	MAINTENANCE AND PROTECTION OF TRAFFIC	1	LS	\$ 4,500.00	\$ 1,000.00	\$ 5,500.00	\$ 5,500.00	\$ 360.00	\$ 552.00	\$ 912.00	\$ 912.00	
8	PAVEMENT MARKINGS, COMPLETE	1	LS	\$ 951.00	\$ 1,425.00	\$ 2,376.00	\$ 2,376.00	\$ 1,050.00	\$ 1,575.00	\$ 2,625.00	\$ 2,625.00	
TOTAL BASE BID (sum lines 1:8)							\$ 53,356.00					\$ 56,119.80

Original Bid \$56,120.00

CERTIFIED BY: 

DATE: 4/29/2024

Signature Page

Resolution No. 2024-05.07.r

A Resolution to Approve an Award of Bid to Spires Paving Company for the CDBG
PY2022 Village of Pleasantville Hickenlooper Street Improvement Project

(Fairfield County Regional Planning Commission)

This resolution has not yet been voted on.

CERTIFICATE OF CLERK

It is hereby certified that the foregoing is a true and correct transcript of a resolution acted upon by the Board of County Commissioners, Fairfield County, Ohio on the date noted above.

A resolution to appropriate from unappropriated in a major expenditure object category for Sheriff's Office Fund 2027 Weights.

WHEREAS, additional appropriations are needed in the major expenditure object category for 2027, Weights; and

WHEREAS, appropriating from unappropriated will allow proper accounting in the major expenditure object category.

NOW THEREFORE, BE IT RESOLVED BY THE BOARD OF COUNTY COMMISSIONERS, COUNTY OF FAIRFIELD, STATE OF OHIO:

Section 1. The Fairfield County Board of Commissioners appropriate from unappropriated into the following category: \$400.00:

\$200.00 23202700 Materials and Supplies
\$200.00 23202700 Capital Outlay

Prepared by: Mendi Rarey
cc: Sheriff

**Appropriate from Unappropriated
For Auditor's Office Use Only:**

\$400.00

2027; 23202700; 561060; Clothing; \$200.00

2027; 23202700; 574000; Equipment, Software & Fixtures; \$200.00

Please appropriate \$400.00 from unappropriated to the above object codes.

Signature Page

Resolution No. 2024-05.07.s

A resolution to appropriate from unappropriated in a major expenditure object category for Sheriff's Office Fund 2027, Weights.

(Fairfield County Sheriff)

This resolution has not yet been voted on.

CERTIFICATE OF CLERK

It is hereby certified that the foregoing is a true and correct transcript of a resolution acted upon by the Board of County Commissioners, Fairfield County, Ohio on the date noted above.

A resolution to appropriate from unappropriated in a major expenditure object category for Sheriff's Office Fund 2394 Litter.

WHEREAS, additional appropriations are needed in the major expenditure object category for 2394, Litter; and

WHEREAS, appropriating from unappropriated will allow proper accounting in the major expenditure object category.

NOW THEREFORE, BE IT RESOLVED BY THE BOARD OF COUNTY COMMISSIONERS, COUNTY OF FAIRFIELD, STATE OF OHIO:

Section 1. The Fairfield County Board of Commissioners appropriate from unappropriated into the following category: \$300.00:

\$300.00 23239402 Contractual Services

Prepared by: Mendi Rarey
cc: Sheriff

**Appropriate from Unappropriated
For Auditor's Office Use Only:**

\$300.00

2394; 23239402; 543000; Repair and Maintenance; \$300.00

Please appropriate \$300.00 from unappropriated to the above object codes.

Signature Page

Resolution No. 2024-05.07.t

A resolution to appropriate from unappropriated in a major expenditure object category for Sheriff's Office Fund 2394, Litter.

(Fairfield County Sheriff)

This resolution has not yet been voted on.

CERTIFICATE OF CLERK

It is hereby certified that the foregoing is a true and correct transcript of a resolution acted upon by the Board of County Commissioners, Fairfield County, Ohio on the date noted above.

A resolution to appropriate from unappropriated in a major expenditure object category for Sheriff's Office Fund 2442 Commissary.

WHEREAS, additional appropriations are needed in the major expenditure object category for 2442 Commissary; and

WHEREAS, appropriating from unappropriated will allow proper accounting in the major expenditure object category.

NOW THEREFORE, BE IT RESOLVED BY THE BOARD OF COUNTY COMMISSIONERS, COUNTY OF FAIRFIELD, STATE OF OHIO:

Section 1. The Fairfield County Board of Commissioners appropriate from unappropriated into the following category: \$15,000.00:

\$15,000.00 23244200 Capital Outlay

Prepared by: Mendi Rarey
cc: Sheriff

**Appropriate from Unappropriated
For Auditor's Office Use Only:**

\$15,000.00

2442; 23244200; 574200; Vehicles; \$15,000.00

Please appropriate \$15,000.00 from unappropriated to the above object codes.

Signature Page

Resolution No. 2024-05.07.u

A resolution to appropriate from unappropriated in a major expenditure object category for Sheriff's Office Fund 2442, Commissary.

(Fairfield County Sheriff)

This resolution has not yet been voted on.

CERTIFICATE OF CLERK

It is hereby certified that the foregoing is a true and correct transcript of a resolution acted upon by the Board of County Commissioners, Fairfield County, Ohio on the date noted above.

A resolution authorizing the disposal of vehicle by internet auction with Gov Deals, Inc.

WHEREAS, Resolution 2017-12.05.d was approved by the Board of County Commissioners to dispose assets through Gov Deals, Inc. for Fairfield County surplus property by internet auction for Calendar Year 2018; and

WHEREAS, ORC 307.12 permits the action; and

WHEREAS, the Fairfield County Sheriff’s Office no longer has a use for multiple vehicles and desire to sell by internet auction; and

NOW THEREFORE, BE IT RESOLVED BY THE BOARD OF COUNTY COMMISSIONERS, COUNTY OF FAIRFIELD, STATE OF OHIO:

Section 1. That the Board of Commissioners approves the disposal of the following vehicles by internet auction:

2016	DODGE CHARGER	2C3CDAXG1GH251836
2016	DODGE CHARGER	2C3CDXAG3GH251837

Section 2. That the Commissioners’ Office process the disposal forms with the Auditor’s Office and notify Clark Insurance to remove from list.

Prepared by: Elisa Dowdy / Sheriff
cc: Lt. Jason Hodder / Sheriff
Sgt. John Warner / Sheriff
Christina Foster / Commissioners

Signature Page

Resolution No. 2024-05.07.v

A Resolution Authorizing the Disposal of Vehicles by Internet Auction with Gov Deals, Inc.

(Fairfield County Sheriff)

This resolution has not yet been voted on.

CERTIFICATE OF CLERK

It is hereby certified that the foregoing is a true and correct transcript of a resolution acted upon by the Board of County Commissioners, Fairfield County, Ohio on the date noted above.

A resolution authorizing the approval of payment of invoices for departments that need Board of Commissioners' approval.

WHEREAS, departments that need the Board of Commissioners' approval for payment of their invoices have submitted their invoices to the County Auditor; and

WHEREAS, the County Auditor has submitted the cash disbursement journal for payment of invoices for the check date of May 9, 2024.

NOW THEREFORE, BE IT RESOLVED, BY THE BOARD OF COUNTY COMMISSIONERS, FAIRFIELD COUNTY, STATE OF OHIO:

Section 1. That the Fairfield County Board of County Commissioners approves the attached cash disbursement journal.

Prepared by: Auditor/Finance
cc: Finance Office

INVOICES BY DEPARTMENT

05/09/2024 to 05/09/2024

Department

Check #	Check Date	Vendor #	Vendor Name	Invoice #	Invoice Date	PO #	Warrant	Line Item Description	Amount
1200			COMMISSIONERS ADMIN						
			Fund: 1001 - GENERAL FUND						
1584685	05/09/2024	80132	AUNDREA N CORDLE	4/25/24	04/25/2024	24000059	C0507	PCSAO NEW DIRECTOR TRAINING	65.26
1584686	05/09/2024	82133	JEFF PORTER	4/24/24	04/24/2024	24000207	C0507	WINDOW SWAG	275.42
5400216	05/09/2024	3720	LANC FF CO CHAMBER OF COMMERCE	49729	04/23/2024	24000015	C0507	2024 CHAMBER AWARDS BANQUET	260.00
								TOTAL: COMMISSIONERS ADMIN	600.68

INVOICES BY DEPARTMENT

05/09/2024 to 05/09/2024

Department

Check #	Check Date	Vendor #	Vendor Name	Invoice #	Invoice Date	PO #	Warrant	Line Item Description	Amount
---------	------------	----------	-------------	-----------	--------------	------	---------	-----------------------	--------

Summary Total for this report: **\$600.68**

Commissioner Steven A. Davis

Commissioner Jeffrey M. Fix

Commissioner David L. Levacy

Date

Signature Page

Resolution No. 2024-05.07.w

A Resolution Authorizing the Approval of Payment of Invoices for Departments that
Need Board of Commissioners' Approval

(Fairfield County Commissioners)

This resolution has not yet been voted on.

CERTIFICATE OF CLERK

It is hereby certified that the foregoing is a true and correct transcript of a resolution acted
upon by the Board of County Commissioners, Fairfield County, Ohio on the date noted above.



TOURISM IS NOT JUST BIG FUN, IT'S BIG BUSINESS!

TOURISMOHIO: WHO WE ARE & WHAT WE DO

2022 economic impact of tourism in Ohio included:

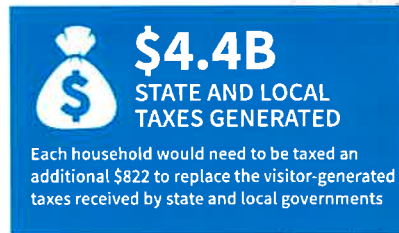

Brand Mission

To showcase all that Ohio has to offer as a place of adventure, a place of promise, and the place for you.

Budget

The FY 24-25 state budget funds TourismOhio at \$7.5M per year. 77% of the budget is spent on the production and placement of advertising and support for communities.

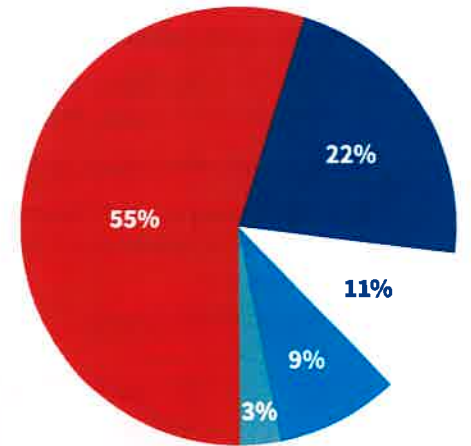

- \$4.1M: Production and placement of advertising
- \$1.7M: Support for communities
- \$812k: Payroll
- \$691k: Overhead and operating costs
- \$225k: Research

Ohio's tourism advertising along with visitation significantly improved the image of Ohio for a wide range of economic development objectives.

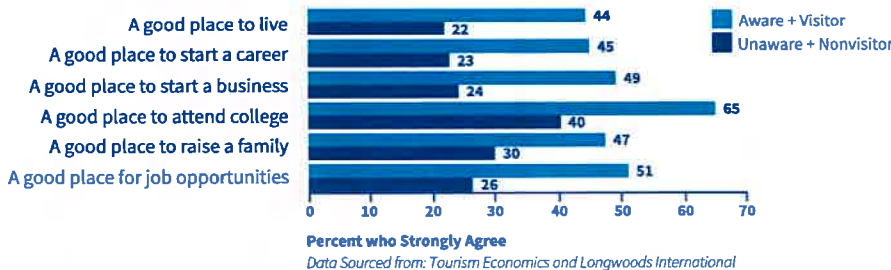

Department of Development

- Lydia Mihalik, Director
- Matt McClellan, Assistant Director
- Katelyn Bowling, Deputy Director, External Operations
- Sarah Wickham, State Tourism Director,
Chief Communications & Marketing Officer
- Tara Marasco, Legislative Affairs Manager

TourismOhio Advisory Board Members

- Lynn Blashford, Chief Marketing Officer, White Castle
- Jason Dunn, Sr., Executive Director, National Coalition of Black Meeting Professionals
- Valerie Freda, Owner, Cabins by the Caves
- Mike Koontz, General Manager and Vice President, Kings Island
- Dan Moder, Executive Director, Explore Licking County
- JP Nauseef, President & CEO, JobsOhio
- Logan Rex, Curator & Communications Director, Armstrong Air & Space Museum
- Lance Woodworth, President & CEO, Destination Toledo
- John Young, CIEIO & Chief Marketing Officer, Young's Jersey Dairy

Fairfield County

How Tourism Supports Your Economy

2021* economic impact of tourism in Fairfield County included:



\$458.8M

VISITOR SPENDING +
INDIRECT BUSINESS SALES



2.2M
VISITS



\$38M

STATE AND LOCAL TAXES
GENERATED



5,076

TOURISM-SUPPORTED
JOBS

Each household in the county would need to be taxed an additional \$664 to replace the visitor-generated taxes received by state and local governments

*County economic impact studies are conducted only every other year.

How TourismOhio Has Supported Your Community

- Inclusion in 3 pieces of prominent seasonal marketing content on Ohio.org that has generated 75,140 pageviews
- Included in the Park It and Central sections of the 2023 *Ohio Travel Guide*; 400,000 copies were distributed
 - The 2023 *Ohio Travel Guide* is nominated for a national PRSA Bronze Anvil Award, Best Publication category
- 45 attraction, destination, and lodging listings on Ohio.org
- One participant at Ohio Tourism Day in 2023, the annual celebration of Ohio's tourism industry and the opportunity for consumers to plan their Ohio vacations
 - Visit Fairfield County



2023 Ohio Travel Guide

400k
COPIES
DISTRIBUTED

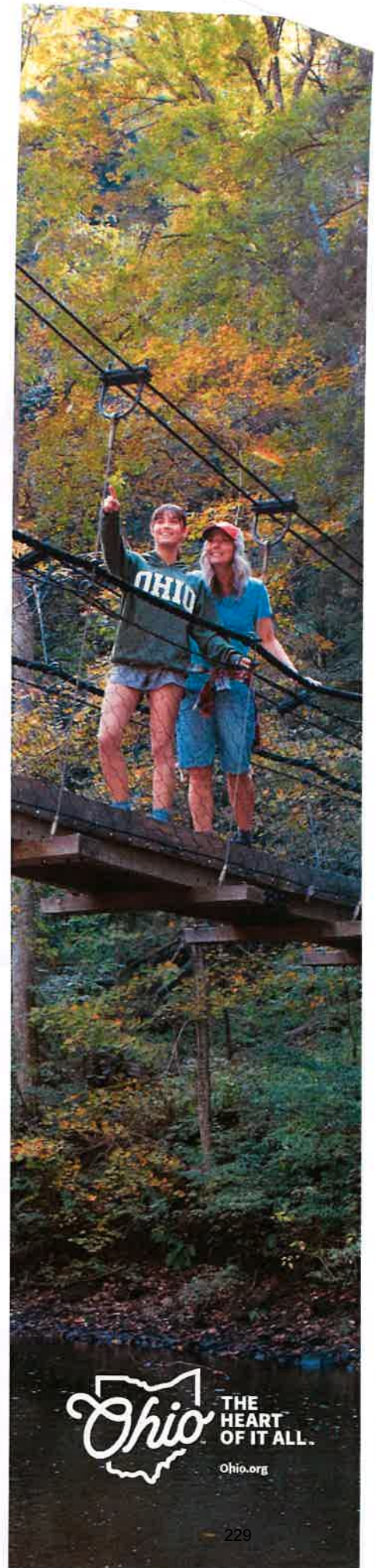

**THIS PAGE
INTENTIONALLY
LEFT BLANK**



**THIS PAGE
INTENTIONALLY
LEFT BLANK**



**THIS PAGE
INTENTIONALLY
LEFT BLANK**



**THIS PAGE
INTENTIONALLY
LEFT BLANK**



**THIS PAGE
INTENTIONALLY
LEFT BLANK**

