

Regular Meeting #21 - 2024
Fairfield County Commissioners' Office
May 21, 2024

Review Meeting

The Commissioners met at 9:00 a.m. at the Liberty Center located at 951 Liberty Dr., Lancaster, OH. Commissioner Levacy called the meeting to order, and the following Commissioners were present: Jeff Fix and Dave Levacy. County employees present: County Administrator, Aundrea Cordle; Deputy County Administrator, Jeff Porter; Clerk to the Commissioners, Rochelle Menningen; Communications & Information Coordinator, Bennett Niceswanger; Budget Director, Bart Hampson; JFS Director, Corey Clark; IT Director, Dan Neeley; Facilities & EMA Director, Jon Kochis; Economic and Workforce Development Director, Rick Szabrak; Utilities Director, Tony Vogel; Auditor, Dr. Carri Brown; Engineer, Jeremiah Upp; Recorder, Lisa McKenzie; Sheriff Lape; Treasurer, James Bahnsen; FCFC Director, Tiffany Wilson; CAUV Specialist, Greg Forquer; Assistant Prosecuting Attorneys, Amy Brown-Thompson, Steven Darnell; Deputies Romine and Hummel, Deputy Treasurer, Michael Kaper; and JFS Finance Director, Josh Crawford. Also present: Sherry Pymmer, Kevin Elder, Betty Elder, Francis Martin, Barb Martin, Jeff Williamsen, Ray Stemen, Earl Cole, Patsy Cole, Betty Bennett, Mary Cullison, Stephanie Taylor, Bryan Everitt, Lisa Thomas, Christina Hill, Beverly Sturm, Shelby Hunt, Cheryl Kohler, Beth Cottrell, Jim Posey, Patti Posey, Jim Posey, Phyllis Hedger, Aaron Steely, Paula Covell, Nancy Gantner, Sharon Brewer, Kris Keller, Tom Leitnaber, Linda Werner, Jean Holdridge, George Holdridge, Bill George, Penny George, Allen Turnbull, Sandy Turnbull, Ed Schooley, Darlene Schooley, William Ball, Kathleen Ball, Dave Holbrook, Cathy Holbrook, Eric Vaughn, Ed Gamble, Beth Smith, Brooke Evans, Judy Zollinger, Selina McCord, Andrew Stratten, Anne Cyphert, Carol Moore, Jerry Starner, Lyne Kennedy-Starner, David Berner, James Miller, Marily Miller Linda Wardilach, Toni Miller, Leigh Miller, Ervin Dumm, Nick Gundren, Austin Reid, Kent Searle, Chad Belville, Ryan Santa Marin, Gina Matos, Brian Compton, Cally Sparrow, Bill Yates, Carol King, Melissa Conner, Teresa Bond, Larry Bond, Ralph Hedrick, Rex Eberly, Jane Eberly, Frank Hudson, Jenny Markwood, Judith Cain, Evon Martin, Aubrey Ward, David Ward, Randy Evans, Joanne Spoth, Paul Sansaucy, Carolyn Solt, Dale Solt, Scott Barr, Pam Covell, Gail Ellinger, Shawn Haughn, Victoria Orchard, Jane Harf, Chris Snider, and William George.

Virtual attendees: Park Russell, Brandi Downhour, Belinda Nebbergall, Nicole S., Joe Ebel, John, Deborah, Jessica Murphy, Britney Lee, Marcy Fields, Jennifer Morgan, Ashley Arter, Aubrey, Lynette Barnhart, Toni Ashton, Aubrey Ward, Will, Lori Hawk, Laurie Hunter, Jerry Starner, Abby King, Jeanie, Leighann Adams, Rachel Elsea, Jason Grubb, Cheryl Berner, Kara Heffelbower, Austin Lines, and Jennifer Morgan.

Welcome

Commissioner Levacy opened the meeting by welcoming everyone in attendance.

Regional Planning Commission (RPC) Update

Interim RPC Director, Holly Mattei, gave an update on the RPC and provided a PowerPoint presentation which is available in the minutes. She stated that RPC is a community based organization that serves all entities in the county and assists townships and villages with long-range planning. The RPC collaborates with other agencies in the county regarding administering Flood Damage Protection Regulations, lot splits for county properties, and assists with zoning technical issues. The RPC is the commercial building department for the county and issues the commercial building permits. The RPC works on the Community Development Block Grant (CDBG) program and there will be a CDBG Hearing on May 28th regarding the grant applicants. The RPC is responsible for taking Fair Housing calls and complaints and is currently completing a Model Zoning Code for the county that would reflect both village and township standards. The

Regular Meeting #21 - 2024
Fairfield County Commissioners' Office
May 21, 2024

zoning code will include all the processes, and entities can adopt as a whole or in part. The first draft of the zoning code will be completed in July.

Ms. Cordle thanked the Commissioners for funding the Model Zoning Code which will be a great benefit for many county villages and townships.

Commissioner Levacy asked which villages and townships have their own existing zoning code and Ms. Mattei replied that Violet Township has its own zoning code.

Commissioners Fix and Levacy, along with Ms. Cordle, thanked Ms. Mattei for leading the RPC and for her assistance with the Comprehensive Plan and the Model Zoning Code.

Airport Update

EMA and Facilities Director, Jon Kochis, provided a PowerPoint presentation (also available in the minutes), and spoke about the Master Plan for the Fairfield County Airport.

Mr. Vogel spoke briefly about the Drainage Study and the water and sewer upgrades for the airport.

Mr. Kochis continued speaking about the 10 unit T-Hangar, the Box hangar, and the new public restroom. He spoke about the 2022 construction estimates and the increases to May 2024 costs, and the increased cost of steel.

Commissioner Davis asked about the impact on funding with the increased costs.

Mr. Kochis provided funding solutions and spoke about the Return on Investment (ROI). There are 27 individuals and companies on the wait list who have placed deposits to lease hangar space.

Commissioner Fix asked if the waiting list indicated we should evaluate rental rates.

Mr. Kochis stated that there is a sub-committee reviewing rental rates and there is a projected 3% yearly increase in rental rates. He spoke about the 15 year financing plan.

Commissioner Davis asked if the General Fund would receive any payments before the 16th year.

Mr. Kochis stated it would not.

Commissioner Davis asked Amy Brown-Thompson if there is a way to guarantee the General Fund repayment.

Ms. Brown-Thompson stated that there is no way to bind that commitment.

Commissioner Fix asked for the construction timeline.

Mr. Kochis stated that the hangar should be completed by February.

Commissioner Davis spoke about the exponential impacts of the airport facilities on the community.

Regular Meeting #21 - 2024
Fairfield County Commissioners' Office
May 21, 2024

Commissioner Fix stated that the concept is that the airport is an economic development tool.

Mr. Kochis stated that you can land a plane at the county airport, park, and be in your vehicle faster than you can land at Port Columbus.

Auditor Brown spoke about the debt process.

Jeff Williamsen from a township neighboring the airport asked about the possibility of future airport expansions and asked if the airport would ever have a terminal.

Mr. Kochis stated that the Fairfield County Airport would never be a controlled airspace and added that the airport currently has a terminal.

Public Comments

Ray Stemen of Lancaster spoke about the importance of spiritual guidance.

Stephanie Taylor of Habitat for Humanity of Southeast Ohio spoke about the upcoming celebration of a home completion, the moving of another home from the Workforce Center, and the two new homes planned in Fairfield County.

Legal Update

There was no legal update.

County Administration Update

- *The County Administration Update was provided by County Administrator, Aundrea Cordle, unless otherwise noted.*

Week in Review

Workforce Center Graduation

The Workforce Center held its annual graduation last week where 83 students graduated.

Highlights of Resolutions

Administrative Approvals

The review packet contains a list of administrative approvals.

Resolution Review

There are 27 resolutions on the agenda for the voting meeting.

Resolutions of note:

- A resolution designating Commissioner Davis as the ad hoc member for the Ohio Power Siting Board.

Commissioner Davis explained that Commissioner Levacy, through the resolution, was designating him to be the Board's ad hoc member for the Ohio Power Siting Board as

Regular Meeting #21 - 2024
Fairfield County Commissioners' Office
May 21, 2024

provided for in Senate Bill 52. Commissioner Davis further explained that the resolution contained the Ad Hoc Board Member Guidelines as supporting documentation. On the Guidelines it states that Under SB 52, ad hoc members are prohibited from voting on intervening resolutions pertaining to industrial solar and wind projects and farms; and are also prohibited from saying anything that would suggest a decision had been made before the end of the application process to the Ohio Power Siting Board.

- A resolution approving the co-sponsorship agreement between the Fairfield County Board of Commissioners and the Fairfield County Airport Authority Board as recommended by the Federal Aviation Administration.
- A resolution from Economic and Workforce Development amending resolution 2022-09.27.k, which established the Fairfield County Route 33 CRS, and its Housing Officer, Housing Council, and TIRC. The amendment adds a representative to the TIRC from the Eastland-Fairfield Career and Technical School.
- The Engineer's Office has a resolution for an agreement to approve American Structurepoint, Inc. for construction inspection and testing services.
- A resolution to approve construction drawings for the Engineer's Salt Barn Storage Facility. You also have a mylar to sign for the project.
- A resolution approving a contract award for the replacement of carpet in the Hall of Justice.
- A resolution approving a plan agreement with CCAO for Inclusion in the Worker's Comp Group Retrospective Rating Plan Program.
- A resolution approving conditional acceptance of the public improvements for the Chesapeake Section 1 subdivision, subject to 3-year maintenance requirements.
- A resolution from the Sheriff's Office approving the disposal of 13 disabled vehicles. These 13 vehicles have a total value of under \$3000.
- A resolution from Utilities approving the contract award to BW Electrical Services, LLC, for the Little Walnut Generator and Transfer Switch Project.

Budget Review

- Budget Director, Bart Hampson reviewed the recent preliminary sales tax information and provided a data sheet that is available in the minutes.

Calendar Review/Invitations Received

- *The review of calendar items, invitations received, and correspondence received was provided by the Clerk to the Board of Commissioners, Rochelle Menningen.*
 - Governor's Executive Workforce Board Meeting, May 22, 2024, 10:30 a.m., Worthington Steel Innovation Center, 7400 Dearborn Dr., Columbus
 - Fairfield County Sheriff's Annual Recognition Ceremony, May 23, 2024, 12:00 p.m., Eagles, Forest Rose Aerie, 1936 E. Main St., Lancaster
 - JFS Family Fun Fest, May 23, 2024, 5:00 p.m., JFS Parking Lot, 239 W. Main St., Lancaster

Regular Meeting #21 - 2024
Fairfield County Commissioners' Office
May 21, 2024

- Fairfield County 4H Endowment Legacy Dinner, June 13, 2024, 5:00
Registration, Cheers Chalet, 1211 Coonpath Rd. NW, Lancaster

Correspondence Received

- Decorative Arts Center of Ohio, Mod Visual Social Cultural Renaissance of the 1960's, June 1 – August 25, 2024
- Bloom Township Resolution 11-24, "To Request the Fairfield County Board of County Commissioners to Create a Restricted Area Prohibiting Large Solar Development"
- Thank You Note from Senior Hub - Meals on Wheels of Fairfield County
- Notice from the Ohio EPA Regarding Issuance of Final Modified Hazardous Waste Permit
- Fairfield County Auditor's Wins of the Week, May 16, 2024
- Memo, Dr. Carri Brown, May 15, 2024, Subject: General Fund Unassigned Fund Balance & General Fund Revenues
- Memo, Dr. Carri Brown, May 16, 2024, Subject: Principal Taxpayers of Real Estate Property Taxes
- Correspondence Regarding Industrial Solar Projects and Exclusionary Zones for Industrial Solar
- Thank You Note from the Director of the Lancaster Festival, Deb Connell
- Fairfield County Auditor's Office's Just the Facts, "How to Make Address Changes"
- Press Release, Office of the County Auditor, May 20, 2024, "Fairfield County Auditor Employees Graduate from Ohio University's Women's Leadership Summit
- Press Release, Office of the County Auditor, May 20, 2024, "Dr. Carri Brown, Fairfield County Auditor, Awarded Recognition of Distinction from Ohio University – Lancaster
- Notice, Fairfield County Health Department, May 20, 2024, "Sewage Treatment System Repair – Healthy Aging Grant Funds Available"
- Fairfield County Board of Developmental Disabilities, May 2024, Imagine Newsletter
- For Immediate Release, Visit Fairfield County Ohio, May 20, 2024, "Visit Fairfield County's 2024 Destination Guide Now Available"

New Business

Engineer Upp spoke about the construction of the salt barn, roadwork on Refugee Rd., and future updates to pedestrian pathways along Refugee Rd.

Commissioner Davis asked about the capacity of the salt barn, the amount of salt used in an average year, if the stored salt had a shelf life, and if the salt we store is rotated for use.

Engineer Upp stated that the capacity of the salt barn is 6000 tons and that the county uses 5500 tons of salt in an average year. He added that the county has never had an issue with stored salt and that the salt is rotated and the oldest is used first.

Regular Meeting #21 - 2024
Fairfield County Commissioners' Office
May 21, 2024

Mr. Szabrak spoke about an opportunity to speak at the first annual Lancaster Schools' Tech Program and that the room was full, and the parents were celebrating. He added that many parents voiced that they were concerned about the vocational paths of their children prior to them entering the tech programs.

Mr. Clark spoke about the JFS Family Fun Fest to be held in the JFS parking lot on May 23rd.

Executive Session

Commissioner Davis made the motion to go into Executive Session at 9:54 a.m. to discuss personnel matters and asked for the following to be in the meeting: the County Administrator, Deputy County Administrator, Representatives from the Prosecutor's Office, the Sheriff, Budget Director, Commissioner Clerks, and Outside Counsel. The motion was seconded by Commissioner Fix

Roll call vote of the motion resulted as follows:

Voting aye thereon: Steve Davis, Jeff Fix, and Dave Levacy

On the motion of Jeff Fix and the second of Steve Davis, the Board of Commissioners voted to adjourn the Executive Session at 10:16 p.m.

Roll call vote of the motion resulted as follows:

Voting aye thereon: Jeff Fix, Steve Davis, and Dave Levacy

Regular (Voting) Meeting

The Commissioners met at 9:00 a.m. at the Liberty Center located at 951 Liberty Dr., Lancaster, OH. Commissioner Levacy called the meeting to order, and the following Commissioners were present: Jeff Fix and Dave Levacy. County employees present: County Administrator, Aundrea Cordle; Deputy County Administrator, Jeff Porter; Clerk to the Commissioners, Rochelle Menningen; Communications & Information Coordinator, Bennett Niceswanger; Budget Director, Bart Hampson; JFS Director, Corey Clark; IT Director, Dan Neeley; Facilities & EMA Director, Jon Kochis; Economic and Workforce Development Director, Rick Szabrak; Utilities Director, Tony Vogel; Auditor, Dr. Carri Brown; Engineer, Jeremiah Upp; Recorder, Lisa McKenzie; Sheriff Lape; Treasurer, James Bahnsen; FCFC Director, Tiffany Wilson; CAUV Specialist, Greg Forquer; Assistant Prosecuting Attorneys, Amy Brown-Thompson, Steven Darnell; Deputies Romine and Hummel, Deputy Treasurer, Michael Kaper; and JFS Finance Director, Josh Crawford. Also present: Sherry Pymer, Kevin Elder, Betty Elder, Francis Martin, Barb Martin, Jeff Williamsen, Ray Stemen, Earl Cole, Patsy Cole, Betty Bennett, Mary Cullison, Stephanie Taylor, Bryan Everitt, Lisa Thomas, Christina Hill, Beverly Sturn, Shelby Hunt, Cheryl Kohler, Beth Cottrell, Jim Posey, Patti Posey, Jim Posey, Phyllis Hedger, Aaron Steely, Paula Covell, Nancy Gantner, Sharon Brewer, Kris Keller, Tom Leitnaber, Le Leitnaber, Linda Werner, Jean Holdridge, George Holdridge, Bill George, Penny George, Allen Turnbull, Sandy Turnbull, Ed Schooley, Darlene Schooley, William Ball, Kathleen Ball, Dave Holbrook, Cathy Holbrook, Eric Vaughn, Ed Gamble, Beth Smith, Brooke Evans, Judy Zollinger, Selina McCord, Andrew Stratten, Anne Cyphert, Carol Moore, Jerry Starner, Lyne Kennedy-Starner, David Berner, James Miller, Marily Miller Linda Wardilach, Toni Miller, Leigh Miller, Ervin Dumm, Nick Gundren, Austin Reid, Kent Searle, Chad Belville, Ryan Santa Marin, Gina Matos, Brian Compton, Cally Sparrow, Bill Yates, Carol King, Melissa Conner, Teresa Bond, Larry Bond, Ralph Hedrick, Rex Eberly, Jane Eberly, Frank Hudson, Jenny Markwood, Judith Cain, Evon Martin, Aubrey Ward, David Ward, Randy Evans, Joanne Spoth, Paul Sansaucy, Carolyn Solt,

Regular Meeting #21 - 2024
Fairfield County Commissioners' Office
May 21, 2024

Dale Solt, Scott Barr, Pam Covell, Gail Ellinger, Shawn Haughn, Victoria Orchard, Jane Harf, Chris Snider, and William George.

Virtual attendees: Park Russell, Brandi Downhour, Belinda Nebbergall, Nicole S., Joe Ebel, John, Deborah, Jessica Murphy, Britney Lee, Marcy Fields, Jennifer Morgan, Ashley Arter, Aubrey, Lynette Barnhart, Toni Ashton, Aubrey Ward, Will, Lori Hawk, Laurie Hunter, Jerry Starner, Abby King, Jeanie, Leighann Adams, Rachel Elsea, Jason Grubb, Cheryl Berner, Kara Heffelbower, Austin Lines, and Jennifer Morgan.

Pledge of Allegiance

Commissioner Levacy asked everyone to rise as able and led the Pledge of Allegiance.

Announcements

Clerk Menningen announced that Fairfield County offices would be closed on Monday, May 27th in observance of Memorial Day.

Approval of Minutes for May 14, 2024, and May 14, 2024, Leadership Conference

On the motion of Jeff Fix and the second of Steve Davis, the Board of Commissioners voted to approve the Minutes for the Tuesday, May 14, 2024, meeting and the May 14, 2024, Leadership Conference.

Roll call vote of the motion resulted as follows:

Voting aye thereon: Jeff Fix, Steve Davis, and Dave Levacy

Approval of Resolutions from the Fairfield County Board of Commissioners

On the motion of Jeff Fix and the second of Steve Davis, the Board of Commissioners voted to approve the following resolutions from the Fairfield County Board of Commissioners:

- | | |
|--------------|--|
| 2024-05.21.a | A Resolution to Establish the Ad Hoc Member to the Ohio Power Siting Board |
| 2024-05.21.b | A Resolution Approving the Co-Sponsorship Agreement between the Fairfield County Board of Commissioners and the Fairfield County Airport Authority Board |
| 2024-05.21.c | A Resolution to Approve a Fund-to-Fund Transfer from the General Fund #1001 to the Flexible Spending Account Fund #7680 |
| 2024-05.21.d | A resolution approving an account to account transfer in a major object expense category for the Safety & Security Budget, General Fund# 1001. |

Commissioner Davis reiterated the information he had provided during the Review portion of the meeting regarding Ad Hoc Members of the Ohio Power Siting Board.

Roll call vote of the motion resulted as follows:

Voting aye thereon: Jeff Fix, Steve Davis, and Dave Levacy

Regular Meeting #21 - 2024
Fairfield County Commissioners' Office
May 21, 2024

Approval of a Resolution from the Fairfield County Auditor - Finance

On the motion of Jeff Fix and the second of Steve Davis, the Board of Commissioners voted to approve the following resolution from the Fairfield County Auditor:

2024-05.21.e A Resolution Authorizing a Fund-to-Fund Transfer, Auditor, Fund #1080

Roll call vote of the motion resulted as follows:

Voting aye thereon: Jeff Fix, Steve Davis, and Dave Levacy

Approval of Resolutions from Fairfield County Economic and Workforce Development

On the motion of Jeff Fix and the second of Steve Davis, the Board of Commissioners voted to approve the following resolutions from Fairfield County Economic and Workforce Development:

2024-05.21.f A Resolution to Amend Resolution 2022-09.27.k, Which Established the Fairfield County Route 33 Community Reinvestment Area (CRA); and the Housing Officer, Community Reinvestment Housing Council, and Tax Incentive Review Council (TIRC) for the Aforementioned CRA

2024-05.21.g A Resolution Authorizing the Approval of Repayment of an Advance to the General Fund, Fund #2881 EV Charging Station Fund

Roll call vote of the motion resulted as follows:

Voting aye thereon: Jeff Fix, Steve Davis, and Dave Levacy

Approval of Resolutions from the Fairfield County Engineer

On the motion of Jeff Fix and the second of Steve Davis, the Board of Commissioners voted to approve the following resolutions from the Fairfield County Engineer:

2024-05.21.h A Resolution to Approve an Agreement between Fairfield County and American Structurepoint, Inc.

2024-05.21.i A Resolution to Approve the Construction Drawings for the Fairfield County Engineer's Salt Barn Storage Facility Project

Roll call vote of the motion resulted as follows:

Voting aye thereon: Jeff Fix, Steve Davis, and Dave Levacy

Approval of a Resolution from Fairfield County Facilities

On the motion of Jeff Fix and the second of Steve Davis, the Board of Commissioners voted to approve the following resolution from Fairfield County Facilities:

2024-05.21.j A Resolution Authorizing the Approval of a Contract Award for the Replacement of Carpet Flooring, Hall of Justice Building

Roll call vote of the motion resulted as follows:

Voting aye thereon: Jeff Fix, Steve Davis, and Dave Levacy

**Regular Meeting #21 - 2024
Fairfield County Commissioners' Office
May 21, 2024**

Approval of Resolutions from Fairfield County Family and Children First Council

On the motion of Jeff Fix and the second of Steve Davis, the Board of Commissioners voted to approve the following resolutions from Fairfield County Family and Children First Council:

- 2024-05.21.k A Resolution to Approve Additional Appropriations by Appropriating from Unappropriated into a Major Expense Object Category, Fund #7521

- 2024-05.21.l A resolution to approve additional appropriations by appropriating from unappropriated into a major expense object category – Fund #7521 – Family Adult Children First

- 2024-05.21.m A Resolution Approving an Account-to-Account Transfer into a Major Expenditure Object Category, Fund #7521

Roll call vote of the motion resulted as follows:
Voting aye thereon: Jeff Fix, Steve Davis, and Dave Levacy

Approval of a Resolution from Fairfield County Human Resources

On the motion of Jeff Fix and the second of Steve Davis, the Board of Commissioners voted to approve the following resolution from Fairfield County Human Resources:

- 2024-05.21.n A Resolution to Approve a Plan Agreement with the County Commissioners Association of Ohio for Inclusion, the Workers' Compensation Group Retrospective Rating Plan Program

Roll call vote of the motion resulted as follows:
Voting aye thereon: Jeff Fix, Steve Davis, and Dave Levacy

Approval of Resolutions from Fairfield County Job and Family Services

On the motion of Jeff Fix and the second of Steve Davis, the Board of Commissioners voted to approve the following resolutions from Fairfield County Job and Family Services:

- 2024-05.21.o A Resolution Authorizing the Approval of a Shared Family Foster Home Agreement by and between Fairfield County Job & Family Services, Child Protective Services Division and South Central Ohio Job and Family Services and Fairfield County Protective Services

- 2024-05.21.p A Resolution to Approve a Memo Expense/Memo Receipt for the Costs of Birth Certificates Paid to Fairfield County Health Departments as a Memo Expenditure for Fund #2072 Public Children's Services

- 2024-05.21.q A resolution to approve additional appropriations by appropriating from unappropriated into a major expense object category – Fund # 2599 – Workforce Fund - Fairfield County JFS

Roll call vote of the motion resulted as follows:
Voting aye thereon: Jeff Fix, Steve Davis, and Dave Levacy

**Regular Meeting #21 - 2024
Fairfield County Commissioners' Office
May 21, 2024**

Approval of a Resolution from Fairfield County Juvenile/Probate Court

On the motion of Jeff Fix and the second of Steve Davis, the Board of Commissioners voted to approve the following resolution from Fairfield County Juvenile/Probate Court:

2024-05.21.r A Resolution Authorizing the Approval of Amendment #2 to the FY24 Grant Agreement between Fairfield County Juvenile Court and Ohio Department of Youth Services

Roll call vote of the motion resulted as follows:
Voting aye thereon: Jeff Fix, Steve Davis, and Dave Levacy

Approval of a Resolution from the Fairfield County Law Library

On the motion of Jeff Fix and the second of Steve Davis, the Board of Commissioners voted to approve the following resolution from the Fairfield County Law Library:

2024-05.21.s A Resolution to Appropriate from Unappropriated Funds for the Fairfield County Law Library Resources Board, Fund 2761

Roll call vote of the motion resulted as follows:
Voting aye thereon: Jeff Fix, Steve Davis, and Dave Levacy

Approval of a Resolution from the Fairfield County Regional Planning Commission

On the motion of Jeff Fix and the second of Steve Davis, the Board of Commissioners voted to approve the following resolution from the Fairfield County Regional Planning Commission:

2024-05.21.t A Resolution to Approve Conditional Acceptance of Chesapeake Section 1 Subdivision

Roll call vote of the motion resulted as follows:
Voting aye thereon: Jeff Fix, Steve Davis, and Dave Levacy

Approval of Resolutions from the Fairfield County Sheriff

On the motion of Jeff Fix and the second of Steve Davis, the Board of Commissioners voted to approve the following resolutions from the Fairfield County Sheriff:

2024-05.21.u A Resolution Approving the Disposal of Thirteen Disabled Vehicles

2024-05.21.v A Resolution Approving an Account-to-Account Transfer into a Major Expenditure Object Category

2024-05.21.w A resolution authorizing the approval of repayment of an advance to the General Fund from Fund 2503 Police Revolving

2024-05.21.x A resolution authorizing the approval of repayment of an advance to the General Fund from Fund 2593 Concealed Handgun License

**Regular Meeting #21 - 2024
Fairfield County Commissioners' Office
May 21, 2024**

Roll call vote of the motion resulted as follows:
Voting aye thereon: Jeff Fix, Steve Davis, and Dave Levacy

Approval of a Resolution from the South Central Major Crimes Unit

On the motion of Jeff Fix and the second of Steve Davis, the Board of Commissioners voted to approve the following resolution from the South Central Major Crimes Unit:

2024-05.21.y A Resolution Authorizing the Approval to Extend the Repayment Date of an Advance of Funds, Fund #7830, Sub Fund #8312 DLEF Grant

Ms. Cordle stated that she will remain in contact with Commander Lowe regarding the repayment of the advance.

Roll call vote of the motion resulted as follows:
Voting aye thereon: Jeff Fix, Steve Davis, and Dave Levacy

Approval of a Resolution from Fairfield County Utilities

On the motion of Jeff Fix and the second of Steve Davis, the Board of Commissioners voted to approve the following resolution from Fairfield County Utilities:

2024-05.21.z A Resolution to Approve the Contract Award for the Little Walnut Generator and Transfer Switch Project; Utilities Fund #5044, Sewer

Roll call vote of the motion resulted as follows:
Voting aye thereon: Jeff Fix, Steve Davis, and Dave Levacy

Approval of the Payment of Bills

On the motion of Jeff Fix and the second of Steve Davis, the Board of Commissioners voted to approve the following resolution for the Payment of Bills:

2024-05.21.aa A Resolution Authorizing the Approval of Payment of Invoices for Departments that Need Board of Commissioners Approval

Roll call vote of the motion resulted as follows:
Voting aye thereon: Jeff Fix, Steve Davis, and Dave Levacy

Adjournment

With no further business, on the motion of Jeff Fix and the second of Steve Davis, the Board of Commissioners voted to adjourn at 10:32 a.m.

Roll call vote of the motion resulted as follows:
Voting aye thereon: Jeff Fix, Steve Davis, and Dave Levacy

The next Regular Meeting is scheduled for 9:00 a.m. on Tuesday, May 28, 2024, in the Commissioners' Hearing Room, 210 E. Main St., Lancaster.



AGENDA

BOARD OF COMMISSIONERS

Commissioners:
Steven A. Davis
Jeffrey M. Fix
David L. Levacy

County Administrator
Aundrea N. Cordle

Deputy County Administrator
Jeffrey D. Porter

Clerk
Rochelle Menningen

Tuesday, May 21, 2024
9:00 a.m.
Liberty Center
951 Liberty Dr., Lancaster

1. Review

Purpose of Review Meeting: *To prepare for formal actions of county business, such as Commission resolutions, and to provide a time for county leadership to connect about matters of county business.*

2. Welcome

3. Regional Planning Commission Update, 9:00 a.m.

4. Airport Update, 9:15 a.m.

5. Public Comments

Purpose of Public Comments: *This is a time for voters and taxpayers (members of the public) to provide comments. There is a time limit of 3 minutes. While this is a time for comments to be provided, it is not a time for questions and answers. The Commission has a full agenda of county business. Please hold all comments regarding industrial solar until the Public Meeting to Consider the Designation of Restricted Area for Industrial Solar at 10:30 a.m.*

6. Legal Update

7. County Administration Update

- a. Week in Review
- b. Highlights of Resolutions
- c. Budget Review
- d. Recognitions/Thank-Yous
- e. Calendar Review/ Invitations Received
 - i. Governor's Executive Workforce Board Meeting, May 22, 2024, 10:30 a.m., Worthington Steel Innovation Center, 7400 Dearborn Dr., Columbus
 - ii. Fairfield County Sheriff's Annual Recognition Ceremony, May 23, 2024, 12:00 p.m., Eagles, Forest Rose Aerie, 1936 E. Main St., Lancaster
 - iii. JFS Family Fun Fest, May 23, 2024, 5:00 p.m., JFS Parking Lot, 239 W. Main St., Lancaster
 - iv. Fairfield County 4H Endowment Legacy Dinner, June 13, 2024, 5:00 Registration, Cheers Chalet, 1211 Coonpath Rd. NW, Lancaster

SERVE • CONNECT • PROTECT



AGENDA

BOARD OF COMMISSIONERS

Commissioners:
Steven A. Davis
Jeffrey M. Fix
David L. Levacy

County Administrator
Aundrea N. Cordle

Deputy County Administrator
Jeffrey D. Porter

Clerk
Rochelle Menningen

f. Correspondence

- i. Decorative Arts Center of Ohio, Mod Visual Social Cultural Renaissance of the 1960's, June 1 – August 25, 2024
- ii. Bloom Township Resolution 11-24, "To Request the Fairfield County Board of County Commissioners to Create a Restricted Area Prohibiting Large Solar Development"
- iii. Thank You Note from Senior Hub - Meals on Wheels of Fairfield County
- iv. Notice from the Ohio EPA Regarding Issuance of Final Modified Hazardous Waste Permit
- v. Fairfield County Auditor's Wins of the Week, May 16, 2024
- vi. Memo, Dr. Carri Brown, May 15, 2024, Subject: General Fund Unassigned Fund Balance & General Fund Revenues
- vii. Memo, Dr. Carri Brown, May 16, 2024, Subject: Principal Taxpayers of Real Estate Property Taxes
- viii. Correspondence Regarding Industrial Solar Projects and Exclusionary Zones for Industrial Solar
- ix. Thank You Note from the Director of the Lancaster Festival, Deb Connell
- x. Fairfield County Auditor's Office's Just the Facts, "How to Make Address Changes"
- xi. Press Release, Office of the County Auditor, May 20, 2024, "Fairfield County Auditor Employees Graduate from Ohio University's Women's Leadership Summit
- xii. Press Release, Office of the County Auditor, May 20, 2024, "Dr. Carri Brown, Fairfield County Auditor, Awarded Recognition of Distinction from Ohio University – Lancaster
- xiii. Notice, Fairfield County Health Department, May 20, 2024, "Sewage Treatment System Repair – Healthy Aging Grant Funds Available"
- xiv. Fairfield County Board of Developmental Disabilities, May 2024, Imagine Newsletter
- xv. For Immediate Release, Visit Fairfield County Ohio, May 20, 2024, "Visit Fairfield County's 2024 Destination Guide Now Available"

8. Old Business

9. New Business

- a. Updates from Elected Officials in Attendance

SERVE • CONNECT • PROTECT



AGENDA

BOARD OF COMMISSIONERS

Commissioners:
Steven A. Davis
Jeffrey M. Fix
David L. Levacy

County Administrator
Aundrea N. Cordle

Deputy County Administrator
Jeffrey D. Porter

Clerk
Rochelle Menningen

- 10. Executive Session to Discuss Personnel Related Matters, 9:30 a.m.**
- 11. Regular (Voting) Meeting**
- 12. Public Meeting to Consider Designation of Restricted Area for Industrial Solar, 10:30 a.m.**
- 13. Adjourn**
- 14. Land Bank Board Meeting, Liberty Center, 11:00 a.m.**
- 15. Transportation Improvement District Meeting, Engineer's Office, 1:00 p.m.**
- 16. Stormwater Utility Update, Engineer's Office, 2:00 p.m.**

SERVE • CONNECT • PROTECT

Quarters Total 2021, Total 2022, Total 2023, & Quarter 1,2 2024 – American Rescue Plan Fiscal Recovery Funds, as of 5.17.2024.

Of the \$30,606,902.00 received at the first and second tranche of the American Rescue Plan Fund \$29,344,024.32 has been appropriated, \$21,172,008.76 expended, \$6,431,526.99 encumbered or obligated.

12Project/Category		As of 5/17/24 Appropriations	As of 5/17/24 Expenditure	As of 5/17/24 Obligation
Public Health				
R00a	Public Health, COVID	1,000,000	1,000,000	1,000,000
R00a	Public Health, Medical Assistance	1,000,000	1,000,000	1,000,000
R000	Public Health, COVID Media Outreach Program	1,000,000	1,000,000	1,000,000
R00a	Public Health, Vaccination Initiatives and Related Expenses	1,000,000	1,000,000	1,000,000
R000	Public Health, Vaccination Incentives and Other Activities of the County	1,000,000	1,000,000	1,000,000
R000	Public Health, Vaccination Incentives for Air Quality Improvement	1,000,000	1,000,000	1,000,000
R00d	Public Health, Vaccination Incentives for Health Department, Mobile Morgue	1,000,000	1,000,000	1,000,000
R00e	Public Health, Vaccination Incentives for Charitable Provider to Respond to Increased Violence	1,000,000	1,000,000	1,000,000
R00a	Professional Services on Behalf of the Board of Health	1,000,000	1,000,000	1,000,000
R000	Public Health, Creation of a County Health Department	1,000,000	1,000,000	1,000,000
R00a	Public Health Department	1,000,000	1,000,000	1,000,000
R000	Public Health Department	1,000,000	1,000,000	1,000,000
R000	Other Public Health Department	1,000,000	1,000,000	1,000,000
R000a	Mental and Behavioral Health	1,000,000	1,000,000	1,000,000
Subtotal Public Health		1,000,000	1,000,000	1,000,000
Negative Economic Impacts				
R000a	Emergency Assistance for Non-Profit Organization, a Grant to the Homeless Shelter	1,000,000	1,000,000	1,000,000
R0000	Emergency Assistance for Non-Profit, Grant The Highline	1,000,000	1,000,000	1,000,000
R0000	Education Grant	1,000,000	1,000,000	1,000,000
R000d	Habitat for Humanity	1,000,000	1,000,000	1,000,000

Quarters Total 2021, Total 2022, Total 2023, & Quarter 1,2 2024 – American Rescue Plan Fiscal Recovery Funds, as of 5.17.2024.

Of the \$30,606,902.00 received at the first and second tranche of the American Rescue Plan Fund \$29,344,024.32 has been appropriated, \$21,172,008.76 expended, \$6,431,526.99 encumbered or obligated.

Project/Category		As of 5/17/24 Appropriations	As of 5/17/24 Expenditure	As of 5/17/24 Obligation
R000e	DOMH0000 Housing Project	0,000,000000	000,000000	0,000,000000
R0000	Harbor House	000,000000	000,000000	0000
R000a	Grant for Tourism, Support for the Airfield County Fair	000,000000	000,000000	0000
R0000	Aid to Tourism, Trade, Hospitality	00,000000	00,000000	0000
R00a	Emergency Response Business Planning	000,000000	000,000000	0000
R000a	Support for Agriculture and the Growing Food Unit	00,000000	00,000000	0000
R0000	Technical Assistance for Townships or Other	000,000000	000,000000	000,000000
R0000	Contract for Services to Support Resident Outing Project of the Landfill	00,000000	00,000000	0000
Subtotal Negative Economic Impacts		0,000,000000	0,000,000000	0,000,000000
R000a	Housing Support, Affordable Housing Strategic Plan	00,000000	00,000000	0000
Subtotal Services Disproportionately Impacted Communities		00,000000	00,000000	0000
Premium Pay				
R00a	Prepaid Pay, Prepaid Pay for Emergency Management General Workers	00,000000	00,000000	0000
Subtotal Premium Pay		00,000000	00,000000	0000
Infrastructure				
R00a	Clean Water Entitled Collection and Conveyance, Airport	000,000000	000,000000	000,000000
R000	Clean Water Entitled Collection and Conveyance, Walnut Creek Sewer District	000,000000	0000	000,000000

Quarters Total 2021, Total 2022, Total 2023, & Quarter 1,2 2024 – American Rescue Plan Fiscal Recovery Funds, as of 5.17.2024.

Of the \$30,606,902.00 received at the first and second tranche of the American Rescue Plan Fund \$29,344,024.32 has been appropriated, \$21,172,008.76 expended, \$6,431,526.99 encumbered or obligated.

Project/Category		As of 5/17/24 Appropriations	As of 5/17/24 Expenditure	As of 5/17/24 Obligation
R000	Clean Water Consolidated Construction and Construction, Regional Distribution	0,000,000.00	000,000.00	0,000,000.00
R00a	Clean Water, Stormwater	000,000.00	000,000.00	000.00
R000a	Drinking Water Construction Distribution, Grant Station	000,000.00	000,000.00	000.00
R0000	Drinking Water Construction Distribution, Airport	000,000.00	000,000.00	000.00
R0000	Drinking Water Construction Distribution, Greenfield	0,000,000.00	000.00	000.00
R000d	Drinking Water Construction Distribution, Bathroom	000,000.00	000,000.00	00,000.00
R000e	Drinking Water Construction Distribution, Treatment	000,000.00	000,000.00	000,000.00
R000a	Broadband, Data Microproject	000.00	000.00	000.00
Subtotal Infrastructure		0,000,000.00	0,000,000.00	0,000,000.00
Revenue Loss				
R00a	Capital and Technological Equipment	000,000.00	000,000.00	000.00
R000	Recorder Document Scanning	000,000.00	000,000.00	000.00
R000	Procurement Case Management	000,000.00	000,000.00	0,000.00
R00d	MR Tower Project	000,000.00	000,000.00	00,000.00
R00e	District Control	000,000.00	000,000.00	000.00
R000	Capital Center Purchase	0,000,000.00	0,000,000.00	000.00
R00g	Capital Center Renovation	0,000,000.00	0,000,000.00	000,000.00
R00h	Community School Attendance Program	000,000.00	000,000.00	00,000.00

Quarters Total 2021, Total 2022, Total 2023, & Quarter 1,2 2024 – American Rescue Plan Fiscal Recovery Funds, as of 5.17.2024.

Of the \$30,606,902.00 received at the first and second tranche of the American Rescue Plan Fund \$29,344,024.32 has been appropriated, \$21,172,008.76 expended, \$6,431,526.99 encumbered or obligated.

Project/Category		As of 5/17/24 Appropriations	As of 5/17/24 Expenditure	As of 5/17/24 Obligation
R000	Workforce Center Expansion	0000	0000	0000
R000	Smart Growth	000,000000	000,000000	0,000000
R000	United Way and Doon Barton Innovation Center	00,000000	00,000000	0000
R61l	Auditor Historical Record Planning	0000	0000	0000
R61m	Engineer Radio	00,000000	00,000000	0000
R61n	Auditor Printer	0,000000	0,000000	0000
R61o	Auditor Paper	00,000000	00,000000	0000
R61p	Breast ID Radio	00,000000	00,000000	0000
R61q	Transportation School Education Vehicle	00,000000	00,000000	0000
R517a	Beaer Field Office	00,000000	00,000000	0000
Revenue Loss		0,000,000000	0,000,000000	000,000000
Administration				
R00a	Administrative Expense	000,000000	000,000000	0000
Subtotal Administration		000,000000	000,000000	0000
Grand Total		\$29,344,024.32	\$21,172,008.76	\$6,431,526.99

ADMINISTRATIVE AUTHORITY ITEMS
FAIRFIELD COUNTY COMMISSIONERS' OFFICE
MAY 13, 2024 TO May 19, 2024

Fairfield County Commissioners

- AA.05.15-2024.a An Administrative Approval for the payment(s) of the United Health Care (UHC) invoice for the Fairfield County Self-Funded Health Benefits Program – Fairfield County Board of Commissioners [Commissioners]
- AA.05.15-2024.b An Administrative Approval to approve the Federal Aviation Administration (FAA) Airport Sponsor Certifications for the FY2024 FAA grant application [Commissioners]
- AA.05.17-2024.a A Resolution Authorizing the Approval of Payments of the Vouchers without Appropriate Carry-Over Purchase Orders and the Cash Disbursement for All Departments that are Approved by the Commissioners [Commissioners]

Fairfield County Court of Common Pleas

- AA.05.13-2024.b An Administrative Approval for a purchase of services agreement between the Fairfield County Court of Common Pleas and Rise up Recovery, Inc. [Common Pleas Court]

Fairfield County Facilities

- AA.05.13-2024.a An Administrative Approval for a signature on an application for a building permit for construction at the Workforce Center. [Facilities]
- AA.05.16-2024.a An Administrative Approval authorizing the approval of an Agreement between Danite Sign Company, and the Fairfield County Commissioners for Parking Lot Signs at the Government Center [Facilities]

GOOD FOOD
GREAT FRIENDS
ONE AMAZING

Legacy

Please join us for the 2024 Fairfield County 4-H Endowment Legacy Dinner

June 13, 2024

Cheers Chalet (note location change)

1211 Coonpath Road NW, Lancaster, Ohio 43130

Cost is: \$75/per person or \$750 per table of 8

Sponsorships available: please see enclosed response card

All proceeds will benefit the Fairfield County 4-H Endowment Fund

Timeline

for the evening:

5:00 p.m. Registration, social hour and silent auction

6:00 p.m. Dinner

6:45 p.m. Silent Auction Closes

7:00 p.m. Program and Live Auction

Thank you for your support

of the Fairfield County 4-H Endowment. Our goal is to generate funds sufficient to endow a 4-H position in Fairfield County and support the 4-H youth development program for generations to come.

2024 Endowment Board Members:

Brittany Auman	Stephanie Mathias
Carol Black	Debbie Miller
Melissa Collins	Ron Ruff
Lindsay Cornett	Crystal Swick
Steve Eversole	Laura Swinehart-Johnson
Brenda Fowler	Tina Taley
Morgan Fox	Leland Tinklepaugh
Michael Friddle	Tiffany Wild
Blake Granzow	Heather Wilson
Greg Grube	

Brin Leigh Hoisington & Julia Ribo
4-H Endowment Youth Representatives

Mark Sharp
4-H Advisory Committee Representative

Leslie Cooksey – 4-H Educator
Aubry Fowler – 4-H Educator

Enclosed, please find my check made payable to the Fairfield County 4-H Endowment for:

Name: _____

Number of Guests at \$75 per ticket: \$ _____

Reservation for a Table of Eight Guests: \$750
Name for Table Reservation: _____

I am interested in a major sponsorship, please contact me!



For your convenience, you may R.S.V.P. online using the above QR code.

Please note all ticket monies received will stay in Fairfield County to help offset the cost of meals and Legacy Dinner expenses.

Please send your reservations with payment to:
Fairfield County 4-H Endowment, P.O. Box 564, Lancaster, OH 43130

Reservations are kindly requested by May 31, 2024

DECORATIVE ARTS CENTER OF OHIO

at the Reese-Peters House

145 East Main Street, Lancaster, Ohio 43130

740.681.1423

www.decarts Ohio.org

FREE ADMISSION

HOURS: Wednesday-Friday, 11AM-4PM | Saturday & Sunday, 1-4PM



Non Profit Org.
U.S. Postage

PAID

Permit No. 278
Lancaster, OH



Aunie Cordle
Or Current Resident
210 East Main St. Room 301
Lancaster OH 43130

|||

Mod

VISUAL
SOCIAL
CULTURAL
RENAISSANCE

of the

1960s

June 1 - August 25, 2024

Mod: Visual, Social, Cultural Renaissance of the 1960s

June 1 – August 25, 2024 | Margaret Wunderlich, CURATOR

Take a journey back to the iconic 1960s. *Mod: Visual, Social, Cultural Renaissance of the 1960s* showcases the decade's influential social revolutions, which continue to shape our visual, societal and cultural landscapes today.

The 1960s were a decade of dramatic change in the United States and beyond. These years saw the election and assassination of JFK, the Cuban Missile Crisis, the moon landing, the Vietnam War, the activism and assassinations of both Malcolm X and Martin Luther King, Jr., and the Stonewall riots. Americans also experienced major developments in reproductive healthcare, civil rights, media technology, workplace equality, medical science, fashion and the arts. The political, cultural and civil movements from this period continue their revolutions today.

The exhibition features a variety of art mediums that include prints, record albums, furniture, housewares, media, décor, jewelry and clothing that reflect the conflicts and creative spirit of a transformative society.

*Presented with support from: The Wendel Family Fund
of the Fairfield County Foundation
and Krile Communications*



Artwork by **SHAG** on display concurrently in the lower gallery

Curator Talk

Sunday, June 2, 2:00PM | \$10/\$5 member | \$15 at the door

Curator Margaret Wunderlich will share insights into the conflicts and creative spirit during the 1960s that inspired her exhibition.

The Art of Collecting

Sunday, June 9, 2:00PM | \$10/\$5 member | \$15 at the door

Margaret Wunderlich and collector Neil Rector will share valuable insight into the art of collecting, delving into the nuances of acquiring and appreciating art and collectibles.

A Good Time is Guaranteed for All: The Soaring Sixties Roar into Central Ohio

Sunday, July 14, 2:00PM | \$10/\$5 member | \$15 at the door

Author Bill Shkurti, *Ohio State University in the Sixties: The Unraveling of the Old Order*, will present images representing how the cultural revolution of the 60s captured the hearts and minds of the local youth—to the dismay of the elders.

Selling at Auction

Sunday, August 18, 2:00PM | \$10/\$5 member | \$15 at the door

Join Curator Margaret Wunderlich to learn about market trends, how to sell at auction and what to look for when assessing the value of antique, vintage and contemporary items. *Bring photos of items you wish to sell at an auction and she will assess it during the Q & A.*

WENDEL CENTER for Art Education

Artistically Embellish Your Denim Clothing • AGES 17–ADULT

Saturday, May 4, 1:00-3:00PM | \$35/\$30 member

Lisa Schorr & Dallas Gossett INSTRUCTORS

Students will create clothing that reflects their personal style using fabric paint, fabrics, beads and embroidery floss. *Students to bring favorite denim item to embellish.*

Add Color to Your Photos • AGES 15–ADULT

Saturday, May 18, 1:00-3:00PM | \$25/\$20 member | Lisa Schorr INSTRUCTOR

Embark on a creative journey that will breathe new life into your cherished memories. Bring 3-5 photos, whether in color or black and white, and watch them undergo a stunning transformation using pigments that will bring them to life on special paper.

The Mourning Train: Bobby Kennedy's Funeral and the Dying Gasp of American Unity

Sunday, August 4, 3:00PM | at the Bexley Public Library

David Steigerwald, a Professor of History at The Ohio State University, will explore how Robert F. Kennedy's funeral in 1968 embodied and refracted many of the deep tensions streaming through American life in the Sixties, and marked the last death of the New Deal-Democratic Party coalition.

Last night (May 13, 2024), the Bloom TWP Board of Trustees adopted the Solar Resolution. Please pass this along to Commission Fix as well. Please feel free to reach out to me if you have any questions.

Thank you,
Anne

-
-
-
-
-

RESOLUTION

-24: TO REMOVE THE AIRBORNE OZONE BOARD OF OZONE COMMISSIONERS TO REMOVE RESTRICTED AREAS PROHIBITING RENEWABLE DEVELOPMENT

WHEREAS, the Board of Trustees of the "Board" of Bloom Township, Fairfield County, Ohio (the "Township") is concerned about the development of solar farms within the unincorporated area of the Township and

WHEREAS, pursuant to Ohio Revised Code Section 307.01, counties may create restricted zones that prohibit the development of large solar facilities in designated areas of the county and

WHEREAS, the Board is concerned about the impact large solar facilities would have on local property value, potential water contamination, and landscape aesthetics, and desire to prioritize the recreation and development of agriculture and

WHEREAS, the Board believes it is in the Township and its residents' best interest to request the County Board of Commissioners to designate the unincorporated area of Bloom Township as a restricted area in which large solar facilities are prohibited

The Board hereby requests the Fairfield County Board of Commissioners to designate the unincorporated area of Bloom Township as a restricted area in which large solar facilities are prohibited

The Township Administrator, or her designee, is authorized and directed to transmit a copy of this resolution to the Fairfield County Board of Commissioners for its consideration

This Resolution shall be in full force and effect immediately upon its adoption

Barbara Moore
Brian Randle
Cameron Smith

Resolution adopted

THE SENIOR
Hub



Dear Commissioners,

Thank you for presenting the Senior Hub - Meals on Wheels Fairfield County with a Proclamation in honor of Older Americans Month.

We appreciate the recognition of our work in support of older adults living in our county but more importantly in recognizing the contributions older adults have made, and continue to make, through their diverse life experiences and engagement with all generations through these experiences. Remember: Aging is so cool... everyone is doing it!

Anna

Mailing List - PUBLIC NOTICE
Fairfield County
OHIO EPA ISSUES FINAL MODIFIED HAZARDOUS WASTE PERMIT

Cirba Solutions US Inc. – Lancaster, Ohio

On April 30, 2024, the Director of Ohio EPA approved the issuance of a Final Class 2 Permit Modification to Cirba Solutions US Inc. (Cirba) for its facility located at 265 Quarry Rd SE, Lancaster, OH in Fairfield County. The purpose of this class 2 modification is to permit a new container storage unit 295-2 for Lithium-ion battery storage, and to reduce the permitted storage capacity of container storage unit 265 Lead-acid battery storage, by the same amount of 300,000 pounds. This modification does not increase the facility-wide permitted container storage capacity. Cirba operates a permitted hazardous waste facility specializing in the management, neutralization, and recycling of all types of industrial/military, automotive, and household batteries. This modified permit allows Cirba to make the requested changes. The EPA ID number for this facility is OHD071654958. To issue this final permit, Ohio EPA determined that the modification application is complete and meets appropriate standards.

You are hereby notified that this action of the Director of Ohio EPA (Director) is final and may be appealed to the Environmental Review Appeals Commission pursuant to Section 3745.04 of the Ohio Revised Code. The appeal must be in writing and set forth the action complained of and the grounds upon which the appeal is based. The appeal must be filed with the Commission within thirty (30) days after notice of the Director's action. The appeal must be accompanied by a filing fee of \$70.00 made payable to "Treasurer, State of Ohio." The Commission, in its discretion, may reduce the fee if by affidavit it is demonstrated that payment of the full amount of the fee would cause extreme hardship. Notice of the filing of the appeal shall be filed with the Director within three (3) days of filing with the Commission. Ohio EPA requests that a copy of the appeal be served upon the Ohio Attorney General's Office, Environmental Enforcement Section. An appeal may be filed with the Environmental Review Appeals Commission at the following address:

Environmental Review Appeals Commission
30 East Broad St., 4th Floor
Columbus, Ohio 43215

A copy of the appeal must be served on the Director within 3 days after filing the appeal with ERAC.



Your Fairfield County Auditor's Office: **WINS OF THE WEEK**

May 16, 2024

Our brains are wired to respond to rewards. Celebrating the completion of small accomplishments leads to the completion of larger goals. And there is evidence in research to support this...According to research by Teresa Amabile from Harvard Business School, tracking small achievements enhances motivation for larger goals ...

- During our all-team meeting, we reviewed the “**all-hands on deck approach**” for the second half tax adjustments, testing, and bill spooling process. We have multiple steps we have taken to communicate from early February until now, and we have a call center planned in June.

★ **The Lancaster Genealogy Society reported they are featuring the maps of the month in their newsletter, and they have some more ideas for maps! Thanks to Nick and his team for the efforts for education and outreach.**

- On Monday, Bev Hoskinson and Carri Brown met virtually with the Engineer's team about their sources and uses of funds for the Basil Western Road project. The update was that there is no rush from their perspective in terms of actually having grant reimbursement from the state. This information will help inform guidance we will receive from Local Government Services about the **accounting structure**. (We also connected with LGS this week.)
- **Work on trial balances began this past weekend! Thanks for the extra efforts from Bev Hoskinson.**
- **On Tuesday, Bev, Angel, Jen, Dave, Nick, Josh, and Linda attended the county leadership conference** where topics of risk management and training were reviewed. Thanks to our representatives who attended and to those who covered the office so that they could attend.

★ **Thanks to Patrick, Carter, Bev, and Carri for meeting with the Fair Boards on Wednesday evening to share information about certification of scales. Thanks to the team for helping Sheetz be ready to open this week, too. Carter Corcoran attended the grand opening.**

- The senior leadership team participated in a work session about communications, the forfeited land procedures, and **the call center plans**.
- A **Destination Downtown meeting** was held on Tuesday, and there continues to be a great deal of excitement about the Spring and Summer plans for Lancaster. Have you been to the Saturday Cinema yet? It is free of charge and is a lot of fun!
- A **Board of Revision meeting was held on Wednesday**, and Linda O'Toole prepared very well for this meeting – which included several complexities.
- Carri attended an **AGA seminar** this week and shared information about GASB pronouncements.
- We created a **fact sheet about address changes** to help with multiple questions about this topic. Thanks to Rachel Elsea for sharing this broadly.

CONTACT US!

Settlements/Admin – (740) 652-7020 • Real Estate - (740) 652-7030

co.fairfield.oh.us/auditor • FairCoAuditor • FairfieldCountyAuditor • FairCoAuditor • fairfield-county-auditor



Your Fairfield County Auditor's Office: **WINS OF THE WEEK**

May 16, 2024

Our brains are wired to respond to rewards. Celebrating the completion of small accomplishments leads to the completion of larger goals. And there is evidence in research to support this...According to research by Teresa Amabile from Harvard Business School, tracking small achievements enhances motivation for larger goals ...

- Thanks to **Josh Harper** and **Noel Sadders** for spending time with a resident who had interest in the mass appraisal process. By explaining the process, there was improved understanding...and the resident called to say how much he appreciated the explanations.

- ★ On Thursday, Carri attended the **Pickerington Annual Chamber meeting** where **Dr. Pam Kaylor's efforts with Celebrate Women** were honored with an annual achievement award. This is the 19th year for Celebrate Women, and we have been so honored to participate over the years. Most recently, it has been a true blessing to expand the **Women's Leadership Summit** with cohorts that included a lot of county participation, too.

- ★ This year, **Jen Dickerson, Crystal Walker, and Michelle Wright** will graduate from the Leadership Summit.



CONTACT US!

Settlements/Admin – (740) 652-7020 • Real Estate - (740) 652-7030

co.fairfield.oh.us/auditor •  FairCoAuditor •  FairfieldCountyAuditor •  FairCoAuditor •  fairfield-county-auditor



To: Fairfield County Commissioners & Staff
From: Dr. Carri Brown, County Auditor
Date: May 15, 2024
Subjects: **General Fund Unassigned Fund Balance & General Fund Revenues**

General Fund Unassigned Fund Balance

The unassigned general fund balance is **\$45,948,063 at December 31, 2023**, up from \$32,556,822 at December 31, 2022. The balances are well within the cash balance policy requirements. Mainly, the increase in the balance is due to increases in collections of sales tax revenue, property tax revenue, and investment earnings (which comprised about 75% of actual revenues), as well as conservative spending policies and support of federal revenues for recovery.

General Fund Revenues

General fund revenues as of **May 15, 2024, are \$26.9 M**. This is 42.1% of the estimated \$63.9 M. Revenue categories are on target in the aggregate. Each category will be monitored for adjustment in estimates (such as with investment earnings) at mid-year.

CONTACT US!

Settlements/Admin – (740) 652-7020 • Real Estate - (740) 652-7030
co.fairfield.oh.us/auditor • X FairCoAuditor • f FairfieldCountyAuditor • @ FairCoAuditor • in fairfield-county-auditor



To: Fairfield County Commissioners & Staff
 From: Dr. Carri Brown, County Auditor
 Date: May 16, 2024
 Subjects: Principal Taxpayers of Real Estate Property Taxes

Here is an advance copy of a table of principal taxpayers of real estate property taxes, looking at the most recent current year and 2014.

**PRINCIPAL TAXPAYERS - REAL ESTATE TAX
 2023 and 2014**

Taxpayer	Type	2023	
		Assessed Valuation	Percent of Assessed Valuation
One Point Three, LLC	Developer	\$ 10,745,000	0.20%
Zane Properties Corporation	Apartments	7,486,730	0.14%
The Flats on Memorial LLC	Apartments	7,471,040	0.14%
Creekside Acquisitions	Apartments	7,201,390	0.13%
Lancaster Apartment Properties	Apartments	6,958,450	0.13%
Brentwood Lake Apartments	Apartments	6,186,190	0.12%
American Homes 4 Rent	Developer	5,910,590	0.11%
AH4R Properties LLC	Developer	5,845,790	0.11%
Kroger Company	Grocery	5,719,740	0.11%
Pickerington Owner 1, LLC	Developer	5,623,500	0.11%
Total		\$ 69,148,420	1.29%
Total Countywide	Valuation	\$ 5,357,544,440	

CONTACT US!

Settlements/Admin – (740) 652-7020 • Real Estate - (740) 652-7030
co.fairfield.oh.us/auditor • FairCoAuditor • FairfieldCountyAuditor • FairCoAuditor • fairfield-county-auditor



2014

<u>Taxpayer</u>	<u>Type</u>	<u>Assessed Valuation</u>	<u>Percent of Assessed Valuation</u>
RVM Glimcher LLC	Developer	\$ 17,700,300	0.56%
Creekside Acquisition	Apartments	6,936,370	0.22%
TEG Brentwood LLC	Developer	6,496,170	0.21%
Pickerington Apartments LLC	Apartments	5,946,260	0.19%
Lakes Edge LLC	Apartments	4,964,150	0.15%
AERC Turnberry Holdings LLC	Developer	4,685,330	0.15%
Regency Centers LP	Developer	4,663,240	0.15%
Lancaster Midtown LLC	Developer	4,494,130	0.14%
DFG Lancaster LLC	Apartments	4,492,660	0.14%
Pickerington Square LP	Retail	4,393,930	0.14%
Total		<u>\$ 64,772,540</u>	<u>2.05%</u>
Total Countywide Valuation		<u>\$ 3,161,437,160</u>	

The amounts presented represent the assessed values upon which 2023 and 2014 collections were based.

CONTACT US!

Settlements/Admin – (740) 652-7020 • Real Estate - (740) 652-7030

co.fairfield.oh.us/auditor •
 FairCoAuditor •
 FairfieldCountyAuditor •
 FairCoAuditor •
 fairfield-county-auditor

May 10, 2024

Dear Commissioners Davis, Fix
and Levacy

As residents of Amanda Township
for 59 years and at our present
home at 5350 Barr Road for
57 years and within 1 mile of
Solar Project, we are asking you
to do ALL that you can to create
exclusionary zones in the unincorporated
areas of Fairfield County to prevent
utility scale solar projects.

Thanks for all that you do.

Ada M. Bradney
Jack L. Bradney

Fairfield County Board of Commissioners
210 East Main Street Room 301
Lancaster, OH. 43130

May 7, 2024

Commissioners Davis, Fix, and Levacy,

I must urge you to pass the exclusionary zone prohibiting utility-scale wind and solar projects in all unincorporated areas of Fairfield County.

For well over one year, I have been researching the pros and cons of these two forms of energy generation and have found that neither constitute using our prime farm land in this way. I firmly believe that Fairfield County will be better served by letting this "opportunity" go unanswered.

Thank you for your consideration.

Sincerely,



Melissa Hoover Connor

7710 Cattail Road NE
Pleasantville, OH. 43148
614-374-1352

Dear Commissioners,

Attached is a copy of the letter that was sent out by EDF Renewables regarding the Eastern Cottontail solar project announcing the commencement of their process before applying to the Ohio Power Siting Board.

Please note the date of EDF's first public meeting is 8 days after the meeting you have scheduled to consider approval of the designation of unincorporated Fairfield County as a solar exclusion zone.

It is imperative that our exclusion resolution be approved at your scheduled May 21st meeting!

This has been a long process, let's carry this across the goal line next Tuesday! There are many that are standing behind you.

**Jeff Williamsen
1201 Winding Oak Dr S
Greenfield Township
Baltimore, OH 43105
813-382-2625**



burst@emailreform.com

To Contact Web; Menningen, Rochelle M

Reply
 Reply All
 Forward

Tue 5/14/2024 2:41 PM

CAUTION: This email originated from outside of the organization. Do not click links or open attachments unless you recognize the sender and know the content is safe.

Your Name*: Ramon Shupe

Office / Department*: Commissioners'

Other: Department:

Email*: randeshupe510@gmail.com

Phone*: 740-969-2564

What can we do to help? NOTE: If this is an urgent request please call the appropriate office* we wish to express a request that you vote yes on exclusionary zones for all unincorporated areas of Fairfield county with regard to a solar industrial plant in Amanda Twp. or AnyWhere in Ohio!!!

5/12/2024

Board of Commissioners for Fairfield County
210 East Main Street
Lancaster, OH 43130

Dear Commissioners Davis, Fix and Levacy:

I am sending you this letter as a resident asking you to create exclusionary zones in the unincorporated areas of Fairfield County to prevent utility scale solar projects.

I live within one mile of proposed solar field in Walnut township and am a Fairfield County resident. I also am the daughter of a farmer and love the farm fields.

My concerns include quality of life for nearby residents, neighboring farms, and wildlife.

These solar farms not only affect the above but they are also simply taking the "fair" fields of Fairfield County and making them ugly and industrial. I often walk down Ridge Rd to Cedarhill Rd and the farm where the solar panels will go is one of the prettiest sights around....it would truly be a shame. Please create exclusionary zones in the unincorporated areas of Fairfield County as soon as possible. Thank you.

Sincerely,

Amy Mosley

May 13, 2024

Board of Commissioners for Fairfield County
210 East Main Street
Lancaster, OH 43130

RE: Exclusionary zones for solar projects

Dear Commissioners Davis, Fix, and Levacy,

It's been two years since the last time I wrote you about the possibility of solar invading our rural township. It was a basic letter that stated that I opposed solar on prime farmland in hopes that that would be the end of our discussion; yet here we are, solar taking up so much of our precious time and resources.

I am not saying that solar is a bad thing. I think alternate energy has its place but not on what the USDA classifies as prime farmland. My husband is a third generation farmer here in Amanda Township. Our home was build by his grandfather in 1954. We have resided at 9650 Lancaster Circleville Road, Amanda, Ohio for the past 26 years. Our farm and home would be almost completely surrounded (the only barrier to the south is another home) by solar panels if you allow these projects to go through. I am asking that you create an exclusionary zone and fight with our township against solar.

Why? Over the past two years you have heard from so many citizens about why we do not want solar in our area. My reasons are the same as theirs. It'd difficult for me to put them in order from greatest to least because they all are valid reasons to consider this as a negative thing for our township. The contract that for the land that is leased directly to the west and north of our farm and home was signed by a man who passed away and regretted his decision. He attempted to be released from his contract but was refused by the company. More land to our north that has been leased was not even leased by the family who owns the land but by an attorney because it is in a trust. The family did not even know the land was leased until the were approached by fellow neighbors asking why they made this particular decision and were shown the map. Are you willing to be a part of the crookedness of these solar companies? National Grid Renewables readily admitted to me that many things went wrong and have not been remedied with the Yellowed project when they approached me back in the Fall of 2023. Fairfield County has a good name that is meaningful, with history and beauty attached to it. As Commissioners, you have actively sought the opinions of your constituents (the new land use plan states that preserving farmland is a top priority) and we are shouting loudly that we do not want solar in areas that are actively zoned agricultural.

As a Mom of 10 children, ages 3-21, who homeschools, living beside an active construction project for who knows how long will be a gigantic distraction to our daily living. We bought our home, from my father in law almost 14 years ago because this is where we desired to bring up our children in the way they should go. We desired a country life, with much of it spent outdoors, enjoying nature and farm life. Waking up each morning to heavy trucks and machinery constantly moving up and down our road, the constant driving of the posts to mount the panels makes me cringe. It will be difficult to spend time outside (like I said, surrounded) with all the dust and noise a project will create and even more difficult to homeschool (so many distractions. I fear for the safety of my kids as there will be so many unfamiliar people so close to our home, turning around in our driveway, skirting the edges of our property on a daily basis. During the summer, my family enjoys taking walks, exploring a small creek on our property

and often we see deer dash into the woods. I know there are other forms of wildlife that will be affected if a project of this size is allowed to go through including coyote, rabbits, groundhogs, moles, squirrels, numerous birds and even the possibility of bald eagles, our national bird, who nest approximately 3 miles from our home on State Route 752 near Ashville, Ohio. Quiet summer moments, grilling out with family and friends, sunset walks and bike rides on the back country road will be ruined for our family if you do not create an exclusionary zone here in Amanda Township.

There are much better options for solar than prime farmland. As a farmer's wife for the past 26 years I have watched my husband give everything to provide financially for our family through agriculture. My 15 year old son, Jude, has already told us that he wants to farm full time when he graduates and has already been a big help during the most recent planting season. He works ground and plants beans. What will be left for my youngest son Jonas, if we set a precedent that big corporations and unknown companies can just swoop in with the mighty dollar and do what they want? Jason is not willing to risk his integrity for the dollar because he believes that farming is essential to the economy and the loss of production of food will impact the world. The damage industrial solar, on land zoned for agriculture, will be detrimental to the fields we farm closest to the leased area. This project will damage tile and drainage and cause flooding to nearby fields (lowering yields and production) and a home directly across from it. It will be impossible to restore the land to its former state due to removal of topsoil (they will have to level because there are rolling hills) and compaction. Our small, township fire department with volunteers would in no way be able to put out any fire created during construction or after the project is complete, leading it to likely spreading to our adjacent field, barns, and home. "Agriculture is now, as it's always been, the basis of our civilization." President Theodore Roosevelt

We are firm believers in property rights; especially living out in the country. We don't want to be subject to an HOA or other organizations telling us what we can or can't do with our property. We have Township Trustees in place to hold us accountable and to properly educate neighbors about their expectations when they move into the area. People are moving here to be away from construction and industry, not to be near it. They are moving here under the impression they are getting away from city living in the "FAIRFIELDS" of Fairfield County. Allowing an industrial solar project, not a "farm" by any means of the vocabulary word to take over our township would decimate our current property values. This is not about property rights but about the good of the whole county/township. My right as a landowner and homeowner needs to be protected. We bought our farm under the impression that we would always be surrounded by things that are rural and agricultural. Which brings me to the point that only one landowner actually lives near the project area that they leased. I live directly beside a project area leased by a landowner that will not have to endure, that hasn't had to endure the what-ifs of solar, the construction of solar and the unknowns of solar. My oldest son has already endured brain cancer once at 15. There are no long term studies to what solar does long term to people, property, WATER, because large scale solar projects have not been around long enough to have them.

Please Commissioners, I'm desperate, do not make my family endure the what-ifs any longer. Please, without hesitation, create exclusionary zones, including Amanda Township, and stop industrial solar and all the negatives that will come alongside it from invading our county. We do not believe in any way that allowing solar in our county will serve and be in the best interest of the people here (energy created doesn't even stay here) and is definitely not a necessity!

Thank you for serving our county.
Respectfully your constituent,
Sarah Leist, letter writer

Jason Leist, farmer and property owner in Fairfield, Pickaway, Hocking, and Ross Counties

Luke Leist, Eden Leist, current voters

Lacey Leist, Jude Leist, Seth Leist, Ruby Leist, Sawyer Leist, Gretchen Leist, Gulianna Leist, and Jonas Leist, children still residing in our home that are watching and waiting alongside us

To: Steven Davis, Jeff Fix and David Levacy,

Hi. My name is Pam Covell. I (and my late husband) signed a lease in October 2020 with National Grid Renewables. Our leased property would be part of the Carnation Solar Project.

I'd like to keep this email as brief as possible so here it goes.

Unfortunately, my husband and I made a mistake! We signed the lease before doing enough research! If we knew then what we know now we would have NEVER signed that lease in 2020!! I feel like we were deceived by National Grid! With the uncertainty or newness of solar panels, maybe there was only limited information to be given!? I just wish there had been more discussions of the area it would encompass and the advantages or disadvantages it would have for the residents within the project area and the entire community !! By the beginning of year 2022..... we wanted OUT !! After hearing concerns from our community and neighbors in the project area and seeing what an eye-sore the panels were, we were no longer interested in leasing our land!!! In 2022 my husband, Pat, had met with an attorney to see if there was any way that we could get out of our lease, but we learned that was not possible. SO, we decided to just wait it out, and pray in the meantime that it would FAIL !!!

More unfortunately, my husband lost his life unexpectedly due to a tragic motorcycle accident in September of 2022!! His loss was huge and mourned by many!! Not just in our community but abroad! So, I am left to fight this fight for both of us!! Save not just our farmland but our neighbor's farmland!! Keep in place the peace and tranquility they feel when sitting on their front or back porches!! Keep the beauty THAT IS, in that area!! Save a reputation that Pat and I have established with the Amanda community!!

Pat and I were born and raised in Fairfield County. Our children were raised in Fairfield County. Our grandchildren as well! ALL of us attending Amanda Clearcreek schools! We started our business, Treton Inc. in Fairfield County. Treton is an established business of almost 18 years and well known in the Amanda area as well as Fairfield County. We are located just outside of Stoutsville. We have always and continue to be big supporters/sponsors for Amanda Clearcreek sports and numerous charities and outings held by the Amanda community and surrounding area.

I know there is much pushback from the community!! We've experienced it on a personal level and business level. The Amanda community is NOT HAPPY about this project !! And I stand with them!! In spite of the fact that I am one of those awful and now regretful landowners that leased my property !! I am sad, scared, and sick of the thought of this project succeeding!! PLEASE listen to me and all the community when we say, "STOP THIS SOLAR THING" !!!

Thank you for your time and consideration!

Respectfully,
Pam Covell



Pamela S. Covell

Treton Inc. ~ President

O: 740.969.9230

F: 740.969.9238

Cell: 740.497.8734

pam@tretoninc.com

Your Name*: Ramon Shupe

**Office /
Department*:** Commissioners'

**Other:
Department:**

Email*: randeshupe510@gmail.com

Phone:** 740-969-2564

**What can we
do to help?**

NOTE: If this is an
urgent request please
call the appropriate

office *:

we wish to express a request that you vote yes on exclusionary zones for all unincorporated areas of Fairfield county with regard to a solar industrial plant in Amanda Twp. or AnyWhere in Ohio!!!

Hi..hope everyone is good...my name is Michelle rodgers..my husband and I found our PERFECT Lil house 🏠 about 19yrs ago..it was only for rent at that time..David and I made it our home..just breath taking sunsets and beautiful land and amazing wildlife all around...WE had our wedding on this picture perfect property📍..UNFAIR AND UNFORTUNATELY my David was killed in a crash...my world destroyed...After that our landlord wanted to see if I wanted to buy our home on a land contract..I said ABSOLUTELY..so many memories here and new ones to be made..welp our contract is up in July and our Lil home on the hill will officially be ours!!!!..Please vote to keep our little peice of Heaven free from those horrible solar panels..this is now our FOREVER HOME ..PLEASE HELP US ALL KEEP IT THAT WAY...thank you for your time and all you do for our county that we all love cherish and RESPECT...THANKS AGAIN

Larry Bond
5234 Barr Rd. SW
Amanda, OH. 43102
May 11, 2024

Fairfield County Commissioners
210 East Main Street
Lancaster, OH 43130

Dear Commissioner Dave Levacy,

As a resident of Amanda Township in Fairfield County, I'm asking you to take action to prevent the use of prime farmland for large scale solar projects. I live less than a mile from the Cedar Hill Road planned solar field, but my concerns are deeper than the "not in my backyard" perspective and those concerns extend to the other large solar projects in Fairfield County.

My concerns include:

- Loss of prime farmland. Projects of this type in neighboring counties have shown little regard for the land with topsoil scraped down to expose subsoil. Any suggestion of farming "between the panels" is deceptive and the restoration of that land to farmland upon removal of the panels at some point in the future is unlikely. Soil removal has been done without regard to existing drainage of those fields.

- Physical presence of large numbers of panels. Solar companies don't want to address the heat created by large black panels. Only about ten percent of the solar energy reaching the panels will be converted to electricity, leaving ninety percent to be reflected or converted to heat. What are the effects on surrounding properties from the possible heat islands created?

- Long term prospects. My experience with solar panels in Ohio have shown very little electricity produced in November through February and reduced efficiency with age worse than marketers promised. If and when government subsidies are reduced, will the operating companies continue to maintain unprofitable panels and associated equipment? What happens if a solar panel field is damaged by hail such as the recent experience in a field in Texas. I fear that the operating company in such a situation would simply declare bankruptcy and walk away.

I ask that you consider these concerns as you are asked to take action for our county.

Respectfully,

Larry Bond

May 15, 2024

Board of Commissioners for Fairfield County
210 E Main St
Lancaster, Ohio 43130

RE: Exclusionary zones for Solar Projects

Dear Commissioners Davis, Fix and Levacy:

I am sending you this letter as a life time resident, land owner, and a Proud farmer's Daughter. I am pleading with you all to PLEASE create Exclusionary zones in the Unincorporated areas of Fairfield County to prevent utility scale solar projects or Any type of solar project that is out there.

I am a Fairfield county resident and live within a few miles of the proposed land and When I visit my daughter and grandsons I will be right next to it. They are definitely not a pretty sight to see. My daughter and her family have over 40 acres they purchased to build their lifetime dream home along with all the amenities of the beautiful country side. They love to spend time on their land by hunting, hiking, exploring, and just enjoying The beauty of the nature of their beautiful property they work so hard to own. It's amazing the wildlife that passes through their property every day.

My concerns are many that come with this issue.

These solar panel farms do not benefit us what so ever. They are a nuisance and eye soar. They ruin the once flourishing farm ground so it's not able to be used again, they take away From the wildlife and their refuge, they will lower our property values, they will just plain and simple not be welcomed at all. The only benefit I see is to the landowners pocketbook. Whose to say that these companies wont go bankrupt, wont stand up to their contract, wont comply with the restrictions? It's been already proven that an attorney is needed for the landowner to protect themselves when this happens. Why would we want something that does not benefit us? There are plenty of other areas and places to install these..... like Florida, Georgia, the Carolina's, Alabama, Texas, where the sun shines more than OHIO! I'm sure people in these areas would welcome them where they are in the middle of no where.

Please Please don't let these hideous panels become a thing of our daily lives and beautiful Landscape.

I again, respectfully ask that you create exclusionary zones in the unincorporated areas of Our beautiful Fairfield County as soon as possible!

Thank you so much for your time,

Rena' Ruble Kilby
3320 Lancaster Circleville Rd Lancaster, Ohio

Good evening Commissioners Davis, Fix and Levacy:

As the meeting on May 21 approaches my family and I want you to know you have our full support in creating exclusionary zones in the unincorporated areas of Fairfield County to prevent the large scale solar projects in our community. As life long residents of Fairfield County my wife and I chose to stay and raise our two children here because we love the people and the beautiful and quiet countryside. With the growing possibility of an approximate 1000 acre solar field going in less than 2 miles from our home we along with our neighbors are growing quite concerned. Our concerns range from the loss of the beautiful landscape (which is a large part of why we moved to our home) to the destruction of land better suited for agriculture. Having seen the progression of the solar fields on Route 22 outside of Washington Courthouse I can't imagine what I would take to properly return those fields back to useful farmland when to solar companies are done with the land. I think there must be much better locations throughout our community that could hold large solar fields. There must be land that isn't suitable for agriculture or the roofs of large warehouses to parking lots that could double as shade for our vehicles. I understand you must weigh the rights of the land owners with leases with the solar companies but what about those of the rest of the county? My family, your neighbors are asking for your help to keep our community beautiful and peaceful for us and future residents by creating exclusionary zones in the unincorporated areas of Fairfield County.

Thank you for your time,

Chris, Roxanne Sams and family

614-214-7545
740-500-2212

10540 Lancaster-Circleville Rd
Amanda, OH 43102

Board of Commissioners for Fairfield County
210 East Main Street
Lancaster, Ohio 43130

May 11, 2024

Dear Fairfield County Commissioners:

We are writing to you in regards to our opposition to the proposed industrial solar projects in Fairfield County. First, we would like to thank you for the evening public meetings so that county residents have a better opportunity to attend.

Tina attended your April 30, 2024 meeting, but chose to not speak in opposition to the industrial solar projects on prime farm ground because her demeanor about this topic has turned to disgust, and she did not want to speak in a manner that would not be professional.

We are disgusted by the foolishness, ignorance and greed that has gripped this issue. The foolishness is the industrial solar companies wanting to bring solar projects to an area of the country that has such little efficiency for large industrial solar energy. The ignorance is the number of people who are believing that these projects would be beneficial to our county - economically and environmentally. And we are disgusted at the observed greed to promote these projects, at the great negative environmental and agricultural costs.

Also, we are disgusted by our inability to trust the players involved in this issue. We do not trust the solar companies who, we believe, are not being honest about the environmental, economic and social impacts to our rural communities that would be involved. We do not trust the unions who seem, in our opinion, to inaccurately represent the actual number of jobs that would be created. And unfortunately, we do not trust the land owners who have signed on with the solar companies and threaten our rural communities and future agricultural potential of thousands of acres of prime farm land.

We are thankful that we have been able to trust several of the township trustees, who, seeking to represent the desires of their constituents, have created resolutions to keep industrial solar out of rural residential areas of their townships. [For us, specifically, we are thankful for Bill Yates and Doug Leith in Walnut Township.]

We are hoping to be able to trust you, as commissioners, to make the right decision to create exclusionary zones for solar projects, keeping industrial solar out of rural residential and agricultural areas in Fairfield County. At the many meetings regarding this topic, your constituents have spoken with intelligence, truth and heart. We, all, have made it clear that protecting the prime farm land our rural communities in Fairfield County will be one of the most important and impactful decisions you will ever make. Please act with immediate diligence and pass whatever measures are necessary to create the needed exclusionary zones for solar projects in Fairfield County.

Thank you for your attention to this matter. Be blessed,

Mike and Tina Milenovic

4292 Canal Road, Pleasantville

David Levacy, Commissioner
Jeff Fix, Commissioner
Steve Davis, Commissioner
210 East Main Street, Room 301
Lancaster, Ohio 43130

Bill Yates, Trustee
Terry Horn, Trustee
Doug Leith, Trustee
11420 Millersport Road
Millersport, Ohio 43046

Dear Commissioners and Walnut Township Trustees,

I am writing today in support of the Eastern Cottontail Solar project in Fairfield County.

We have the ability to create high-wage jobs close to home, adding value to my community and our local economy. Our energy supply should be diverse and provide opportunities for our workforce. Projects such as Eastern Cottontail help facilitate the development of a thriving workforce of local Ohioans.

Eastern Cottontail Solar will support approximately 450 project development and onsite labor jobs, in addition to 7 long-term jobs for operations and maintenance.

These construction jobs are essential to the health of our economy and development as well. Local small businesses such as restaurants will see a measured increase in traffic through the project building, driving incentives to create more business within the community and further supporting Fairfield County. A project like this is an invaluable way to create economic growth without sacrificing the community.

I urge you to approve this project.

Name: Grace Schmalfelch

Address: 1612 Bushhill dr Lancaster OH

cc: Ohio Power Siting Board

David Levacy, Commissioner
Jeff Fix, Commissioner
Steve Davis, Commissioner
210 East Main Street, Room 301
Lancaster, Ohio 43130

Bill Yates, Trustee
Terry Horn, Trustee
Doug Leith, Trustee
11420 Millersport Road
Millersport, Ohio 43046

Dear Commissioners and Walnut Township Trustees,

I am writing to say I am in support of the Eastern Cottontail Solar project in Fairfield County for many reasons, one being the positive benefits this project would have on our local and statewide environment.

We must bring clean, non-polluting development into our communities and state, especially those that can help us meet a growing energy demand.

Not only would the development of Eastern Cottontail ensure that Fairfield preserves farmland for future generations, it would also maintain the robust wildlife habitat better than a housing development or other infrastructure that may be placed on the land.

Renewable energy projects like Eastern Cottontail Solar are an important part of the future of Ohio's economy and environment. The economic, community, infrastructure, and health benefits this project will bring our state are significant.

I urge your support of the Eastern Cottontail Solar Project.

Name: *John Knapp*

Address: *4890 Township rd 138 NW Somerset*

cc: Ohio Power Siting Board

David LeVacy, Commissioner
Jeff Fix, Commissioner
Steve Davis, Commissioner
210 East Main Street, Room 301
Lancaster, Ohio 43130

Bill Yates, Trustee
Terry Horn, Trustee
Doug Leith, Trustee
11420 Millersport Road
Millersport, Ohio 43046

Dear Commissioners and Walnut Township Trustees,

I want to urge you to approve the permit application for the Eastern Cottontail Solar project being developed in Fairfield County.

The Eastern Cottontail Solar project represents tangible growth and development for Fairfield County. It generates sustaining annual revenues and construction jobs. As a resident of Fairfield, I am always in favor of supporting development within our community.

Eastern Cottontail Solar also brings benefits to critical municipal services, including schools and fire departments. These community benefits create opportunities for new businesses and more development in Fairfield County that positively impact our way of life.

In addition to the wonderful benefits our community would receive, Eastern Cottontail would ensure Ohio remains at the forefront of innovation. To maintain our reputation, we must continue to encourage development of all kinds, including diverse energy development such as solar, within our state.

Thank you.

Name: *Matthew A. Blair*

Address: *1536 River Valley Circle S.
Lancaster, OH 43130*

cc: Ohio Power Siting Board

I am writing to say I am AGAINST the Eastern Cottontail Solar project in Walnut Township because it will increase my cost of electricity.

Wind and solar advocates often cite a metric called the [Levelized Cost of Energy \(LCOE\)](#) to claim that these energy sources are cheaper than coal, natural gas, and nuclear power plants.

However, these claims, which are already tenuous due to [rising wind and solar costs](#), ignore virtually all of the hidden real-world costs associated with building and operating wind turbines and solar panels while also keeping the grid reliable, including:

- Additional transmission expenses to connect wind and solar to the grid;
- Additional costs associated with [Green Plating](#) the grid;
- Additional property taxes because there is more property to tax;
- “Load balancing costs,” which include the cost of backup generators and batteries;
- **Overbuilding and curtailment costs incurred when wind and solar are overbuilt to meet demand during periods of low wind and solar generation and are turned off during periods of higher output to avoid overloading the grid;**
- These comparisons also ignore the cost differential between low-cost, existing power plants and new power plants.

When factoring in the above parameters (Source: Isaac Orr, Center of the American Experiment):

- The LCOE for Wind is 7.8 times that of Coal, 10 times Natural Gas CC, 2.9 times Natural Gas CT, and 7.3 times Nuclear.
- The LCOE for Solar is 13.5 times that of Coal, 17.4 times Natural Gas CC, 5 times Natural gas CT. and 12.7 that of Nuclear.

How that is reflected in actual rates is not a one-to-one but you can bet that electric utility costs in areas in the US that have aggressive ‘green’ programs have been increasing at an alarming rate.

I urge you to REJECT the application of the EDF/Eastern Cottontail solar project.

Cc: Fairfield County, OH Commissioners

URL: <https://dis.puc.state.oh.us/DocumentRecord.aspx?DocID=0b109d92-f024-4a82-8c81-edf367d4223f>

Date & Time: 5/17/2024 at 08:24:05.4407728 EST

Case Number(s): 24-0495

Summary: Public Comment electronically filed by Jeffrey Williamsen.

Confirmation Number: 0d3cd65f-ffa0-4ea0-9546-efb38c609f43

Jeffrey Williamsen
1201 Winding Oak Dr S, Baltimore, OH 43105
813-382-2625

May 15, 2024

Board of Commissioners for Fairfield County
210 East Main Street
Lancaster, OH 43130

RE: Exclusionary Zones for Solar Projects

Dear Commissioners Fix, Dewey and Davis:

I am sending this letter as a land owner in the Amanda Township asking you to create exclusionary zones in the unincorporated areas of Fairfield County to prevent utility scale solar projects. I live adjacent to land currently being considered for such a project.

I am concerned that these utility scale projects will cause the loss of prime farm land that will never be farmed again due to soil compaction and damage to topsoil. It will forever change the farmland that I believe is at the heart of Fairfield County. I moved to my farm over thirty years ago because it was an agricultural

property and I want it to stay that way. The agricultural zoning drew me to this particular property and rural residential rights need to be protected.

In addition to my love of the agricultural setting, I am also concerned that my property value will go down significantly if I am surrounded by such an invasive utility project. Who will want to live on a farm surrounded by ugly solar panels?

I believe that such projects are better suited to more industrial areas or on smaller scales such as home or business rooftops.

I ask that you create exclusionary zones in the unincorporated areas of Fairfield County as soon as possible.

Thank you for your time and attention.

Judith A. Cain
9705 Westfall Road SW
Amanda, OH 43102

Dear Commissioners Davis, Fick and Levoacy

It seems that people today are fixated on the "here and now" and have somewhat of a "me" attitude. No one seems to know or care about history or "the past", nor do they care about planning for the future. We as a people are only on this earth for a very short time in the big scheme of things and we are only caretakers of this earth for the period of time that we are here. Therefore, it is our responsibility to leave this earth and this land in better shape than when we found it for the next generation to steward.

My name is Jim Jepsen, and I am a 3rd generation farmer living in Amanda township of Fairfield County. My Grandfather's farm was in Violet township, outside of Canal Winchester, and is now covered by warehouses. My Father's farm, where I grew up, is in Bloom township and is literally surrounded by housing developments. My farm, where my wife and I reside, is literally within a stones throw of one of the proposed industrial solar developments in our county. I am not naive enough to believe that growth and development are not inevitable, but to often I believe decisions are made based on the financial or political gain of a chosen few,

with no regard for the lasting repercussions of these decisions for the many, whose lives will be affected for generations to come.

Let me be clear. I am not necessarily anti-solar. We, as farmers, use it ourselves to provide alternative power to our farms by utilizing everything from panels on our barn roofs, to solar powered fence chargers. But the idea of sacrificing thousands of acres of some of the best soil in this country, let alone Fairfield County, seems reckless and irresponsible. Farmers are naturally conservationists and environmentalists. We know that to provide a sustainable food source for a growing population, we must take care of our number one resource, which is the farmland.

According to the U.S. Census Bureau, the United States population increases by one person every 24 seconds, or 3600 people per day. In contrast, according to the U.S. Department of Agriculture, the United States loses 175 acres of farmland every hour, or 4000 acres per day. This ratio is simply not sustainable. I understand that this growing population will need an affordable, reliable, sustainable energy source, but using

this county and this country's number one non-renewable, non-replaceable, resource of farmland is not the answer. There has to be a better solution, but that is a discussion for another time.

You gentlemen have a very important job to do, and decision to make. I know that you have pondered this situation for many months now, but the time has come to take a stand. I urge you to set precedent and vote to create exclusionary zones in the unincorporated areas of Fairfield County to protect our farmland from large scale industrial development. Future generations are depending on you.

Thank you for your time,
respectfully submitted,

Jim Jepsen

5270 Drum Rd.

Amanda, Ok. 43102

614-560-5919



OHIO
UNIVERSITY
Chillicothe

101 University Drive
Chillicothe OH 45601-0629

T: 740.774.7200
F: 740.774.7214
W: www.chillicothe.ohiou.edu

May 16, 2024

Fairfield County Board of Commissioners
210 East main Street, Room 301
Lancaster, Ohio 43130

Dear Fairfield County Commissioners,

I am writing this letter in support of National Grid Renewable with whom we have partnered since 2021. The plans to begin work on the 274 megawatt solar photovoltaic electric generating facility located on about 2,000 acres now called The Yellow Bud Solar Project first led to a representative from National Grid Renewable reaching out to OHIO University Chillicothe. Since then, our partnership with the organization that provides cost-effective renewable energy generation has grown in meaningful ways.

National Grid Renewable has been an excellent community partner with whom we have collaborated in the creation of an Education Cooperation Agreement as part of the Ohio Qualified Energy Project (QEP) Exemption under Ohio Revised Code Section 5727.75. The Education Cooperation Agreement between Yellowbud Solar Project and OHIO Chillicothe has allowed us to realize an anticipated and welcomed revenue stream that can be directed toward university programs in Science, Technology, Engineering, Mathematics, and Education related to renewable energy. Additionally, Yellowbud has agreed to provide onsite tours to our students on an annual basis which will give our students an authentic and up-close opportunity to learn about the solar energy industry.

In sum, as an educational institution, OHIO Chillicothe has benefited from our partnership with National Grid Renewables. It has enabled us to enhance some of our educational opportunities that have a positive impact on our students and help to keep them competitive. I believe other communities can also benefit from such collaborations and would encourage this exploration.

Sincerely,

Roberta Milliken, Ph.D.
Dean of Campus and Community Relations
millikenr@ohio.edu

Dear Commissioners Steve Davis, Jeff Fix, and Dave LeVacy,

I am a 46 year resident of 9575 Westfall Rd. Amanda, Ohio. I am deeply concerned about the possibility of a solar power plant right across from my front yard.

I am concerned for many reasons including environmental, loss of property value, and loss of my current quality of life. I am also concerned about how this solar power plant would affect the hard-working farmers in my area who farm the land.

I urge you to Pass the resolution designating all or part of the unincorporated area of the Fairfield county as a restricted area, prohibiting the construction of large solar facilities, and wind farms.

Thank you,
Linda Werner

May 17, 2024

Board of Commissioners for Fairfield County

210 East Main St.

Lancaster, Ohio 43130

RE: Exclusionary zones for Solar projects

Dear Commissioners Davis, Fix and Levacy,

We are residents and a land owner in Amanda Township/Fairfield County and writing to ask you to create exclusionary zones in the unincorporated areas of Fairfield County to prevent utility scale solar projects.

We are very concerned and ask that you protect our beautiful, rural community. My husband has lived here his whole life and helped his grandfather farm as he grew up in this beautiful farm country. We raised our three sons here. We love living here with the beautiful, peaceful, rolling fields with wonderful sunrises and sunsets! I can't imagine looking out to a mass field of solar panels. Having served on Amanda Township's Zoning board, the property zoned as agricultural and rural should be protected by our zoning guidelines. Isn't that what they are for....to protect our property and our rights as landowners?? As a neighboring, concerned person of this community, I ask that you please protect our farmland. The value of our property is at stake as well. We would lose prime farmland, this would damage the soil and leave the land never to be farmed again. We feel there are better locations for projects like this in more industrial areas or businesses and warehouses. Our children and grandchildren live here in Amanda Township as well. Our children chose to stay in this area to raise their children in the country, with the amazing farmland, nature and wildlife.

I again ask you to create exclusionary zones in the unincorporated areas of Fairfield County as soon as possible.

Thank you for your time and consideration.

Jill and Jeff Pontius
343 Cedar Hill Rd. SW
Amanda, Ohio 43102

May 18, 2024

Dear Commissioners,

Thank you for allowing me to voice my concerns about the pending solar panels that will surround our land in Amanda. Your decision will change the lives of my family and my neighbors. My husband, Randy and I, along with our Aunt are the owners of Clearcreek Country Vineyard on Westfall Road.

Our Uncle Gary, Aunt Shirley's husband, dreamed of putting an operating vineyard and tasting room on his family's farm for many years before he retired. He worked tirelessly to prepare for it. He drove back and forth from Lancaster, PA to prep the property to start his dream for several years. He planted his vines, built a working barn and started building the house of his dreams where he and his wife would retire, enjoy the fruit of his vines and live on his homestead the rest of his life.

Unfortunately, in 2011, Gary passed away soon after his retirement without seeing his dream become a reality. His wife, Shirley, with our help took on the challenge of making the vineyard a business where others could purchase his wine and enjoy the country setting.

Fast forward to today. The vineyard is celebrating its 10 Year Anniversary as an operating vineyard and winery. Shirley, Randy, myself and several of our adult children continue to work the vineyard and build the business Gary put in motion. We have created a place where others can come, relax, enjoy the calm country setting and share a glass of wine with friends. Our family is truly blessed to have this opportunity, and we want to be able to continue to share what we have with our family and our community. Through the years, our customers come out to the vineyard to enjoy the beauty surrounding us. The peaceful sunsets. The sounds of the animals are soothing and restful. Our customers retreating from the city are blown away by our view. We laugh sometimes when they comment about how beautiful a wheat field is or how relaxing it is to look at a field of corn, because to us, it's just what we expect living in the country. And there is not a day that goes by that we are not thankful. And we never take this property or this business for granted. Especially now.

Solar Panels surrounding our vineyard will change life for us. We have 4 generations and 5 households of our family living within an eighth of a mile of our property. I do not have to share with you the potential negative aspects of what the solar panels are going to do to our view, our soil, the water supply, the wildlife and property value in our area. I know those fighting against this in our community have already given you all of this information. I am also assuming, you have done your research so you will be able to make the best decision for our community. Our business will never be the same if our view is solar panels. They are directly beside us and behind us. Maintaining our healthy lifestyle is also at stake with toxins filling our water and damaging our soil.

With all that being said, I understand property owners have the right to do whatever they want with their property, but when it affects the livelihood and health of their neighbors, I feel we need to stand up for what's right. We need YOU. We need you to stand up to this for us because we cannot do it on our own. We can't calculate right now how much this will change our lives, but we know it will. It's a heaviness that hangs over many families in our community. Thank you for listening. I appreciate your time.

Christine Evans

Owner, Clearcreek Country Vineyard and Winery

Hi. Please pass the zone to protect our county. It would be greatly appreciated so we would still have our working farm lands. Need to protect our land for our younger relatives!!

Thanks.

Linda Beth Smith.

12068 Bright St

Millersport, OH 43046

Dear Commissioners Davis, Fix, and LeVacy:

I am sending you this email as a concerned citizen asking you to create exclusionary zones in the unincorporated areas of Fairfield County to prevent utility scale solar projects. I am a Fairfield County landowner.

As a landowner, I have many concerns. A couple of my main concerns are:

- Agriculture – loss of prime farmland, damage to field tiles, noxious weeds, land will possibly never be able to be farmed well again due to soil compaction and damage to topsoil, the loss of a generation of farmers who know how to care for the land
- Disruption to the wildlife in the area – deer and other wildlife will be disrupted causing accidents, loss of habitat, and even death to the wildlife. There are known nests of bald eagles in this area,
- Property rights – the property rights of nearby and adjoining landowners who chose to live and invest in their property as an area zoned as agricultural and rural residential need to be protected

I again urge you to create exclusionary zones in the unincorporated areas of Fairfield County

Thank you for your time.

Beverly Sturm

1556 Rathmell Road

Lockbourne, OH 43137

[E] ban utility size solar projects



Jim and Margo Washburn <jimbo.165@hotmail.com>
To [Contact Web](#)

[Reply](#) [Reply All](#) [Forward](#) [Share](#) [More](#)
Sun 5/19/2024 10:45 PM

Start your reply all with: [Thank you!](#) [Received, thank you.](#) [I would be happy to participate.](#) [Feedback](#)

CAUTION: This email originated from outside of the organization. Do not click links or open attachments unless you recognize the sender and know the content is safe.

I am sending you this email as a concerned citizen asking you to create exclusionary zones in the unincorporated areas of Fairfield County to prevent utility scale solar projects.

Laurie Powers
8640 Lancaster-Thornville Rd NE
Pleasantville Ohio 43148
Ohio Power Siting Board

Case #24-0495-EL-BGN

May 18, 2024

I am writing to you to voice my concern and opposition to the Eastern Cottontail industrial solar project in our community. To make myself clearer, I am absolutely totally against this project and ask that you listen to us as those who will be affected negatively by this project and approve the proposed exclusionary zone.

We have lived here in our house since 1988. We have made many improvements to add to the value of our home over the years. Several realtors have told us that if Eastern Cottontail is approved to have industrial solar panels all around it will definitely cause our property value to decrease by up to 40%. Why should that be allowed?

Our property has been affected by broken field tiles already by retaining water when it rains. The issue of more water due to more broken-field tiles by the process of Eastern Cottontail installing the solar panels is a huge concern of ours. Even though they have said it will not, what guarantee do we have that it won't and what will be done when we have flooding issues?

Health concerns about what the industrial solar panels will do to our ground water and the soil is huge! This is something that plays very heavily on me. We have raised livestock and raised our own food in the past and with the increasing costs of things have considered doing it again but with this concern I would not. I'm not even sure I want to drink the water or even shower knowing that there are so many unaware chemicals draining into the ground and into our well water.

The unsightly views are something that I never thought would be an issue in our beautiful farmland surrounding our home. Siting on the back porch and just taking in those beautiful and peaceful views have always been my relaxing place. That will totally not be the case if Eastern Cottontail is permitted to go through with this project. Coming down Cattail Rd to 188 stop sign is an issue with the poor visibility. Having that field full of industrial solar panels will make that even worse.

To change the zoning to benefit only a few compared to those against it is not using the American judicial system the way it was created for. We who live here should have the right to vote on what happens in our community, not those who don't. I ask that you please take our opinions and concerns and do what's right for us

Thank you for your time and sincere consideration in this matter

Laurie Powers Cc: Fairfield County Commissioners

4/29/24

Board of Commissioners for Fairfield County
210 East Main Street
Lancaster, Ohio 43130

RE: Exclusionary Zones for Solar Projects

Dear Commissioners:

I am sending you this letter as an Amanda Township Landowner, farmer, and business owner. I am asking you to create exclusionary zones in the unincorporated areas of Fairfield County to prevent utility scale solar projects. My land is within three miles of the proposed area and I am concerned with the impact that a solar project will have not only on my land but for all residents of Amanda Township.

I was born and raised in Amanda Township and it has been my dream to farm the land that I once explored as child. Now that my boys and I own the land, we are working to preserve this land for our future generations. We have been working for many years to continue to use our land to raise and harvest crops, as well as creating a habitat for our local wildlife to thrive. The idea of prime agricultural land being destroyed for the use of solar projects, is a travesty. Not only are we taking the use of land away, but we are opening the door for major issues resulting from the construction of the area.

Construction of this magnitude, will most definitely cause major issues for the Amanda Township area. I currently live near the new Google plant that is being built on Whiley Road. From day one there have been many issues. First there has been the destruction of land, that is now the site of a major building project. As this construction takes place there has been major issues with dust, traffic congestion, accidents, and road damage. Whiley Road has been repaired once, but currently is in need of repair again, due to the heavy loads that are transported on it. Not only have these issues plagued nearby residents, but everyone living adjacent to the property has had to put up with noise, lighting, and they have lost their lovely view of the countryside. Not only are they dealing with these issues, but will never be able to receive the true value of their homes, if they decide to sell.

Many of the people I have known all of my life have been affected by the Google construction. I have seen how it has left a negative impact on them and their properties. I do not want the same situation to happen to those friends and neighbors of mine in Amanda Township. To lose the lovely views that many of them have from their properties would be a tragedy.

This project will not only effect humans but also our local wildlife. Once construction starts animals will have no choice but leave their current habitats in search of new. This will cause them to move through the area and more than likely will come in contact with drivers, endangering not only themselves but humans as well. Construction in this area would cause is the destruction of the natural habitat for our local wildlife. The projected site of the solar project, is known to be frequented by our country's national symbol, the Bald Eagle. It is important to note that while Bald Eagles are no longer on the Endangered Species list, they are still protected under the federal Bald and Golden Eagle Protection Act, as well as state law. There is much wildlife, in our area that need this land and what it provides. By using this land for a solar project, we are risking the loss of habitat, soil, and plants. All of these items are important components for wildlife survival. What wildlife does not need is the disruption of their migration paths, loss of habitat, soil erosion and soil health. Solar panel projects have not only caused

these issues but have also been known to create high temperatures, water runoff, as well as reflective surfaces that can cause "Lake Effect".

I do not feel that this project will benefit Amanda Township or Fairfield County. It only benefits people in other states, where the electricity will be routed to, and for the property owners of the project site. A majority of these property owners will not be affected by the issues outlined above, as they do not reside in the area.

Thank you for your time,

Matthew J. Kleinline

Matthew J. Kleinline

Sent from my iPhone

Dear commissioners Davis ,Fix and Levacy, I am writing to urge you to pass exclusionary zones for rural residential areas of Fairfield county. Industrial projects do not belong near our homes and families, affecting every thing from traffic to noise and property values. Thank you.

Karl Elder

5669 Elder Rd NE

Pleasantville, Ohio 43148

From: [eric.vaughn](#)
To: [Contact Web](#)
Subject: [E] No Solar
Date: Monday, May 20, 2024 9:24:58 AM

CAUTION: This email originated from outside of the organization. Do not click links or open attachments unless you recognize the sender and know the content is safe.

To whom it may concern,

I am writing to express my strong concern regarding the installation of solar panels near my property. I do NOT want to be next to a solar farm. The destruction of the land, soil, trees, and destruction of the value of the surrounding community would be enough to cause a house, being next to a solar farm would be enough to cause the roof to fall.

We also don't benefit from it at all. Do we get a tax break or do we get cheaper electricity? No, we don't. Generated or lower property value. No. The only people that benefit, don't have to be next to it.

I am a major renewable energy, but not where it is a legitimate. On farmland in a low sunlight, date and destroying the surrounding community does not make sense.

Thank you for your time,
Eric Vaughn
Address: 12345 Main Street, Suite 100, Road

Thank You
for serving
Fairfield County

5-10-24

Dear Mr. Severy,

I am writing this note to
ask you to please vote YES
to create exclusionary zones.

Thank you,
Catherine J. Ryan
217 S. Mt Pleasant
Lancaster OH 43130

5-18-24

Dear Mr. Fitz,

I am writing this note
to ask you to please vote
YES to create exclusionary
zones.

Thank you,
Catherine Ryan
217 S. Mt Pleasant
Lancaster OH 43130

From: [Marshall, Rebecca @ Columbus](#)
To: [Contact Web](#)
Subject: [E] Exclusionary Zones for Solar Projects
Date: Monday, May 20, 2024 9:57:49 AM

CAUTION: This email originated from outside of the organization. Do not click links or open attachments unless you recognize the sender and know the content is safe.

Dear **Commissioner David, Jim and Cecilia**

I am sending you this email as a concerned citizen asking you to create exclusionary zones in the unincorporated areas of airfield county to prevent utility scale solar projects. I am an airfield county resident and owner, residing at 11111 State Rd, Middletown, Ohio.

Scale solar zones on 10 or 20 acre and should **NOT** be allowed. These type of solar projects will negatively affect the quality and value, protect state and rural water rights that we voted to this county for. It will harm the local environment, wildlife and deplete the local economy that depend on agriculture and tourism. **But please do not mention the personal health of the county or solar generation as the amount and use is a very inefficient and long term local energy and residential rooftop and not in open or forested, agricultural and rural land.**

I urge you to create exclusionary zones in the unincorporated areas of airfield county.

Thank you for your time.

Rebecca Marshall | Senior Real Estate Manager

[BR](#) [Project Management](#)

200 Civic Center Drive, Fourteenth Floor | Columbus, OH 43215

T 614 430 5010 | F 614 224 1767 | C 614 565 8865

rebecca.marshall@cbre.com | www.cbre.com/columbus

Follow CBRE: CBRE.com | [LinkedIn](#) | [Twitter](#) | [Instagram](#) | [Facebook](#)

Please consider the environment before printing this email.

This email and any attachments contain information that is confidential or attorney-client privileged and a confidentiality in disclosure. The content of this email is intended only for the recipient(s) listed above. If you are not the intended recipient, you are directed not to read, disseminate, distribute or otherwise use this transmission. If you have received this email in error, please notify the sender immediately and delete the transmission. Deletion of this message is not intended to waive any applicable privilege.

Details about the personal data CBRE collects and why, as well as your data privacy rights under applicable law, are available at [CBRE – Privacy Policy](#).

From: [Bickers, Greg](#)
To: [Contact Web](#)
Subject: [E] Exclusionary Zones for Solar Projects
Date: Monday, May 20, 2024 10:09:38 AM

CAUTION: This email originated from outside of the organization. Do not click links or open attachments unless you recognize the sender and know the content is safe.

Dear Commissioner David, Jim and Cecilia

I am sending you this email as a concerned citizen asking you to create exclusionary zones in the unincorporated area of Fairfield County to prevent utility scale solar projects. I am a Fairfield County resident and owner, residing at 11111 State Rd, Middletown, Ohio.

Scale solar zones on 10 or R and should **NOT** be allowed. These type of solar projects will negatively affect the quality and pace, protect the land and rural way of life that we voted to this county for. It will harm the local environment, wildlife and deplete the local economy that depend on agriculture and tourism. **But please do not mention the personal health of the county or our generation as the amount of land use is a very inefficient and long term local and residential rooftop and not in open or forested, agricultural and rural land.**

I urge you to create exclusionary zones in the unincorporated area of Fairfield County.

Thank you for your time.

Greg Bickers
Senior Manager Workplace Ops
Talent & Enterprise Services, Workplace Operations
[Greg Bickers | Fairfield Mutual](#)
State Auto Insurance | Fairfield Mutual Insurance
11111 Broad St, Columbus Ohio 43001
Office
Email

From: [Linda Watts](#)
To: [Contact Web](#)
Subject: [E] Exclusionary Zones for Solar Projects
Date: Monday, May 20, 2024 10:12:57 AM

CAUTION: This email originated from outside of the organization. Do not click links or open attachments unless you recognize the sender and know the content is safe.

Board of Commissioners for Fairfield County
100 East Main Street
Canton, Ohio 44705

Dear Commissioners Steve Dard, Dennis, and Dale DeLoe

I am sending you this letter as a land owner/owner in Grand and Hoping Township Fairfield County and would like to ask you to create an exclusionary zone in the unincorporated area of Fairfield County to prevent utility poles from being erected. While our land is primarily farmed, we do have a small wooded area filled with wildlife and several habitats for a wide variety of animals.

I have been trying to follow the information I can find about the Industrial Utility Pole Project proposed for Grand Township. While we would want to give you credit for the need our nation is in, the history has shown us what can happen when there is no way to feed the population. This is on one point, several other concerns are yours to residents. The project will create a wide area of damage in an area including rain water runoff directed around the area, overgrowth of wild weeds no longer needed for farming. The amount of time to recoup the land back into farming will double in the ten years. More trees are being cut down around the pole project cutting down on a township fire fighter and the loss of our rural beauty to construction project and the noise that comes with pole area.

My husband worked very hard to be able to live in this beautiful area of Fairfield County and now that we, along with many others are the age of retirement, would it be taken for the benefit of a few cities elsewhere?

Farmland has always been an important asset in this area. Going far away in it will be lost due to not only the agriculture industry, but also their knowledge being passed down to the future farmer needed to grow enough for feeding our nation and the world.

Please consider the mentioned factors as you vote for the benefit of our County and our constituents. Please create an exclusionary zone in the unincorporated area of Fairfield County as soon as you can.

Thank you for your assistance and your time with this important matter.

Linda Watts
1000 Harg Rd W
Grand, Oh 44705

From: [Michael Ayers](#)
To: [Contact Web](#)
Subject: [E] Industrial Solar
Date: Monday, May 20, 2024 10:37:57 AM

CAUTION: This email originated from outside of the organization. Do not click links or open attachments unless you recognize the sender and know the content is safe.

As owners of a 450 acre grain farm, we are opposed to allowing good productive farmland to be made into solar farms.

This has been a family farm for the last 80 years with 4 generations still living on the farm.

Mike and Carlene Ayers

From: [Jennifer Farmer](#)
To: [Contact Web](#)
Subject: [E] Amanda Township solar project
Date: Monday, May 20, 2024 10:59:49 AM

CAUTION: This email originated from outside of the organization. Do not click links or open attachments unless you recognize the sender and know the content is safe.

Dear Commissioners Davis, Fix & Levacy,

I am writing in regards to the possible building of an industrial solar complex in Amanda Township. I ask that you vote YES for exclusionary zones in this area.

My family has lived in the township for almost 15 years and we chose our home due to its rural location and slower pace of life. We were shocked and disappointed to find out that there was a plan to build industrial solar panels across the street and properties around our area.

Please consider the impact on our family and our neighbors due to the dust, traffic, construction noise and possible drainage issues. Also, no doubt, our property value would decrease which in turn would reduce property taxes collected by the county. The negative effects of this project far outweigh the positives.

We enjoy our home and seeing deer in the fields, hearing pheasants close by and all the other wildlife that frequent. It would be devastating to see this agricultural land be put to industrial use.

I appreciate your consideration of voting yes on creating an exclusionary zone in Amanda Township.

Sincerely,
Jennifer Farmer and family
9695 Lancaster Circleville Rd.
Amanda, OH 43102

- he dust, noise, traffic, drainage issues, or other problems with construction
- The reduction in your property values the project would cause- Research shows this is more pronounced in rural areas like ours and with larger projects like the proposed project.
- Damage to field tiles causing damage to nearby farms and homes.
- Permanent change from an agricultural area to an industrial site.
- ***These are not solar farms, but industrial solar complexes.***

He is asking you to ignore you to peace protect our country and making the one our friend are
horrible for the environment in to a and waste a we have an eye core. We do not need nor want the in
our country. They are a waste of one and threat to to the environment. So at what this
earth has to offer. So are destroying her with the our friend. Let alone to a and other thing. Reg
o you to a the environmental one to that our friend can be used a the were meant to be used.

Thank you.

Roger

RE: Approve the proposed exclusionary zones for Solar Projects

Case #24-0495-EL-BGN

Email: Contact@fairfieldcountyohio.gov

Website: WWW,OPSB.OHIO.GOV

Date: 5/20/2024

Fairfield County Board of Commissioners

210 East Main Street

Lancaster, Ohio 43130

Dear Commissioners Davis, Fix and Levacy along with the Ohio Power Siting Board

I am writing this letter to address my concerns with this new solar energy that will be placed in my backyard. I believe this needs to be further researched as there is a lot of disinformation. As always, more truthful info seems to come out later than at the beginning. I have been doing a lot of research in our area as well as other areas with these solar projects.

Reasons for my concerns:

1. Flooding, lightning strikes, topography, weeds, solar company honoring its agreements, levies and taxes, fixed sum levies and increases, wastelands, incurable defects labels by real estate, thunderstorm and tornado incubators and magnets, hail damage, noise and the liens against our property when solar company does not pay their bills.
 - A. Company only fixes main tiles, not the laterals
 - B. Texas recently had a lightning storm that demolished the solar tiles
 - C. When planting the posts, land flow is changed so water runoff flows differently now
 - D. How often will they mow. Indian Lake Ohio project weeds were taller than the panels
 - E. Solar company companies in Indian Lake Ohio has changed hands 3 times already. Also individual folks who signed on for solar panels in Ohio cannot get the solar companies to repair the product. Three different companies are involved so you have to wade through all 3 companies to see who has the parts and who does the installation.
 - F. Solar companies go bankrupt or gov't subsidies change, the pilot money goes to so you have nothing.
 - G. Areas that have fixed sum levies will have the taxes not being paid and that will be divided among the taxpayers.
 - H. What happens if the property is abandoned, who long would decommissioning take along with returned back to agricultural zoning?
 - I. Solar may be labeled as incurable defect by the real estate industry. Incurable defects may diminish property values, reduce assessment values, lower taxes raised on the town, county and school.
 - J. Solar farms become thunderstorm and tornado incubators and magnets

This was written by retired aerospace engineer, George Franklin and posted to the internet on Dec 22, 2023.

Solar panels are at best about 20% efficient. They convert almost 0% of the UV light that hits them, none of the visible spectrum and only some of the IR spectrum. At the same time as they are absorbing light, they are absorbing heat from the sun. This absorbed HEAT is RADIATED INTO the adjacent ATMOSPHERE. It should be obvious what happens next. When air is warmed, it rises. Even small differences in ordinary land surfaces are capable of creating powerful forces of weather like thunderstorms and tornadoes. These weather phenomena are initiated and reinforced by land features as they are blown downwind, It is all too obvious to me what will happen with the heat generated by an entire solar farm. Solar farms will become thunderstorm and tornado incubators and magnets.

Solar panels are dark and they emit energy to the space above them when they are not being radiated. This is known as black-body radiation. Satellites flying in space use this phenomenon to cool internal components. If they did not do this, they would fry themselves.

So solar farms not only produce more heat in the summer than the original land that they were installed on, but they produce more cooling in the winter, thus exacerbating weather extremes.

There is nothing green about green energy except the dirty money flowing into corrupt pockets. There is no such thing as green energy. The science does not exist. The technology doesn't exist. We are being pushed to save the planet with solutions that are worse than the problems.

Comments from the article: Many of the solar panels in southern Illinois are trashed in hail storms. One place had to replace the panels twice, then gave up and took it all out.

- K. Hail Storm on 3/16/24 in Needville Texas Large solar farm leaking in the water tables. Massive damage.

Perhaps if these solar panels are so necessary, we can come up with other solutions:

1. In South Korea, the solar panels are in the middle of the highway and have bike paths beneath them.
2. Place them in the cities on top of buildings instead of using our prime farmlands.

It is just so sad to see this happening in my backyard. I just recently retired and paid off my house. With all the reasons for my concerns listed above, **especially letter J**, I again believe we need to rethink this.

Just like the other solar projects, such as wind mills and electric cars, they are not working out to produce the carbon reductions and savings as they represented in the beginning.

Why would we want to jump on these solar panels and ruin our valuable farmlands with runoffs and storm damages poisons, reduce our property values, create a possible financial ruin for our county with levies, taxes and liens and all the noise. We cannot even be assured that these solar companies will uphold their commitments to repairs, to maintain the weeds and tell the truth as so much disinformation has been spoken.

Thank you for your time,
Cindy and Mike Claar
4675 Canal Rd.
Pleasantville, Oh 43148
www.Citizensforfairfields.org

Footnotes:

Indian Lake Ohio meeting notes see A-H above
Stop Solar Farms article under Citizen for Fair Fields see I above
Stephenville resident, George Franklin article from retired rocket

5/15/2024

Board of Commissioners for Fairfield County
210 East Main Street
Lancaster, Ohio 43130

RE: Exclusionary zones for Solar projects

Dear Commissioners Davis, Fix and Levacy:

I am sending this letter as a home owner less than a quarter mile from a proposed solar project (Amanda Township / Carnation Solar project), 9726 Ridge Road. I am asking you to create exclusionary zones in the unincorporated areas of Fairfield County OH to prevent utility scale solar projects.

This acreage for this proposed site is prime agriculture fields. It currently produces valuable yields for the residents right here in Fairfield County and throughout Ohio. Not only as a food source for ourselves/livestock but the vast number of jobs it entails to go from seed to table impacting our community. Eliminating this production will cause higher prices for our community and loss of jobs that are not one and done.

My biggest concern is my property rights. We moved to Amanda with the reassurance that Amanda Township was **ZONED FOR OUR PROTECTION**. We had every confidence that the property we purchased would be protected by the legality of the zoning implemented. We have invested money, time not to mention buying local materials from surrounding suppliers for the improvements to our home. Our home is our most valuable asset and should only be increasing in equity. Our home with all its improvements and care only **adds value** to our surrounding neighbors, and vice versa. This proposed site does the complete opposite to the surrounding homeowners. All our painstaking equity grown in our homes will be eroded by our neighbors' decision to add value to their acreage but in contrast will be catastrophic to the surrounding landowners' values and property rights.

Another area of concern is our current infrastructure of roads in our Township's. Our roads were not developed to handle Industrial traffic and will pose a danger to other drivers and pedestrians that use these roads for their personal travel. The roads are narrow with soft shoulders and are completely different than the State Routes where other industrial solar fields in the state are located.

These fields are vast habitats for wildlife including if not most importantly our most important pollinator the BEE. OSU has done studies on how valuable soybean fields are to the population of our bees. I have just named a few important reasons what utility solar projects can be detrimental to our beautiful Fairfield County. **LAND IS A FINITE RESOURCE**. Agriculture field is not a blank slate. It is already being productive in a vast number of ways to our community.

I am asking you to create an exclusionary zone in the unincorporated areas of Fairfield County as soon as possible.

Thank you,

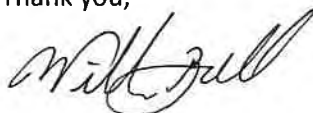

William Ball

5/15/2024

Board of Commissioners for Fairfield County
210 East Main Street
Lancaster, Ohio 43130

RE: Exclusionary zones for Solar projects

Dear Commissioners Davis, Fix and Levacy:

I am sending this letter as a home owner less than a quarter mile from a proposed solar project (Amanda Township / Carnation Solar project), 9726 Ridge Road. I am asking you to create exclusionary zones in the unincorporated areas of Fairfield County OH to prevent utility scale solar projects.

This acreage for this proposed site is prime agriculture fields. It currently produces valuable yields for the residents right here in Fairfield County and throughout Ohio. Not only as a food source for ourselves/livestock but the vast number of jobs it entails to go from seed to table impacting our community. Eliminating this production will cause higher prices for our community and loss of jobs that are not one and done.

My biggest concern is my property rights. We moved to Amanda with the reassurance that Amanda Township was **ZONED FOR OUR PROTECTION**. We had every confidence that the property we purchased would be protected by the legality of the zoning implemented. We have invested money, time not to mention buying local materials from surrounding suppliers for the improvements to our home. Our home is our most valuable asset and should only be increasing in equity. Our home with all its improvements and care only **adds value** to our surrounding neighbors, and vice versa. This proposed site does the complete opposite to the surrounding homeowners. All our painstaking equity grown in our homes will be eroded by our neighbors' decision to add value to their acreage but in contrast will be catastrophic to the surrounding landowners' values and property rights.

This area of Fairfield County is so beautiful that it is regularly used as a **recreational scenic bikeway** for multitudes of bikers and motorcyclists enjoying the beautiful scenery as together these routes connect more than 400 Ohio communities for intrastate travel, recreation and tourism. Do you really think bikers/tourists will continue to use this scenic bike route travelling into our community with a view of high steel fencing, pillars of concrete and fields of black shiny glass?

These fields are vast habitats for wildlife including if not most importantly our most important pollinator the BEE. OSU has done studies on how valuable soybean fields are to the population of our bees. I have just named a few important reasons what utility solar projects can be detrimental to our beautiful Fairfield County. **LAND IS A FINITE RESOURCE**. Agriculture field is not a blank slate. It is already being productive in a vast number of ways to our community.

I am asking you to create an exclusionary zone in the unincorporated areas of Fairfield County as soon as possible.

Thank you,



Kathleen Ball

OUR CHANGING NEIGHBORHOOD

LET'S SAVE THIS PICTURE FOR OUR HISTORY BOOKS.

LOOKING NORTHEAST FROM THE CORNER OF CEDAR HILL ROAD AND RIDGE ROAD, AMANDA TOWNSHIP



BRUCE E. BABCOCK 5/12/2024

Bruce & Marlene Babcock
11155 Stout Road SW
Amanda, Ohio 43102



Commissioners,

Thank you for recommending the Lancaster Festival for the Chamber Non Profit of the Year. It is a great honor to be recognized by our community. Your support is very much appreciated!

All my best,
Deb Connell



How to Make Address Changes

Auditor's Real Estate Office

Mailing Address Changes

A request to change a mailing address can be made by visiting <http://real-estate.co.fairfield.oh.us> and attaching the report for the property associated with the change. Once at the report page, the report owner can click on the red link under the Owner Information tab.

Property owners will need to submit information for mailing address, name of the requester, phone number of the requester, email address for the requester, and the relationship to the property owner.

Once the request is submitted, the office is notified of the change and will proceed with updating the record according to the redoubt, address change were requested by calling the office to have the information changed or re-release, including a tutorial can be found here:

<http://itmm.R-address-change>

Questions Regarding Site Addresses

If there is a question regarding a site address (e.g. house number), please use the link mentioned above. The Auditor's Office may need to contact you or the Engineer's Office for further clarification.

Treasurer's Office – Tax Bills

Please see the Treasurer's office advised when you move, change lender, or desire your tax bill to go to a different address using the MMR MMR TORM FORM found here:

<http://itmm.MMR>

Return it to:

James N. Bahnsen
Fairfield County Treasurer
210 E Main St. Rm. 105
Lancaster, OH 43130

Or via email to auditeat@fairfieldcountiohio.gov

Please note that you have a unique parcel ID number for which you want the mailing address changed, please list the address on the form if you do not need to submit separate forms for each parcel number.

According to the Ohio Revised Code, failure to receive an address required by this section does not excuse failure or delay to tax an estate shown on such form, except as provided in division B of section of the Revised Code, avoid an penalty, interest, or charge for such delay.

CONTACT US!

Settlements/Admin – (740) 652-7020 • Real Estate - (740) 652-7030

co.fairfield.oh.us/auditor • FairCoAuditor • FairfieldCountyAuditor • FairCoAuditor • fairfield-county-auditor



FOR IMMEDIATE RELEASE

Monday, May 20, 2024

Fairfield County Auditor Employees Graduate from Ohio University’s Women’s Leadership Summit

Lancaster, Ohio - County Auditor, Dr. Carri L. Brown is pleased to announce that three of her team members have participated in Ohio University’s Women’s Leadership Summit held at the Lancaster campus and organized by Dr. Pam Kaylor and Dr. Candice Thomas-Maddox. On May 18, 2024, Jen Dickerson, Michelle Wright, and Crystal Walker graduated from this Leadership Summit.

This comprehensive training program was designed for women to establish and enhance leadership skills. “We are thankful to these women leaders for their participation and investment of time into their leadership journey,” stated Dr. Brown.

Previously, Rachel Elsea and Angel Horn, also with the County Auditor’s Office graduated from this same program in 2023. Along with the most recent graduates, they will continue to participate in data gathering efforts to inform a study on the development of women leaders.

For more information about this new release, please contact Rachel Elsea, Communications Officer for the Fairfield County Auditor’s Office, at (740) 652-7030.



###

Follow Your Auditor’s Office On **Social Media!**



linkedin.com/company/fairfield-county-auditor



@FairCoAuditor



@FairCoAuditor



@FairfieldCountyAuditor



co.fairfield.oh.us/auditor



realestate.co.fairfield.oh.us



Newsletter

SERVE • CONNECT • PROTECT



FOR IMMEDIATE RELEASE

Monday, May 20, 2024

Dr. Carri Brown, Fairfield County Auditor, Awarded Recognition of Distinction from Ohio University – Lancaster

Lancaster, Ohio - On Friday, May 17, 2024, Dr. Carri L. Brown, Fairfield County Auditor, was awarded Recognition of Distinction from Ohio University Lancaster. Dr. Pam Kaylor and Dr. Candice Thomas-Maddox, both Communication Studies Professors at Ohio University, presented the honor in recognition of Dr. Brown’s “invaluable contribution as a Leadership Educator for the 2022-2024 Women’s Leadership Summit.” The Leadership Summit was a comprehensive training program designed for women to establish and enhance leadership skills.

“It is so humbling and such an honor to be a part of this tremendous effort with Ohio University. The Summit was a way to foster a culture of empowerment for women in our community. It was encouraging to witness how women were developing a growth mindset and were aspiring for excellence,” stated Dr. Brown.

Dr. Brown volunteered as an instructor and key member of the Women’s Leadership Advisory Committee, a committee that designed and organized the program.

If there are organizations who would like to have a presentation about leadership, Dr. Brown is available to share concepts from the Leadership Summit. For more information about this new release, please contact Rachel Elsea, Communications Officer for the Fairfield County Auditor’s Office, at (740) 652-7030.

###

Follow Your Auditor’s Office On **Social Media!**



linkedin.com/company/fairfield-county-auditor



@FairCoAuditor



@FairCoAuditor



@FairfieldCountyAuditor



co.fairfield.oh.us/auditor



realestate.co.fairfield.oh.us



Newsletter

SERVE • CONNECT • PROTECT



Fairfield County
Health
Department



Are you 60 or older and have a sewage system needing repair or replacement? We may be able to help!

Sewage Treatment System Repair - Healthy Aging Grant Funds Available

Health Aging Grant funds are currently available for low and moderate-income Fairfield County homeowners, who are 60 or older, with failing septic systems.

These funds can pay to repair or replace an existing system, or to connect to public sewers if available.

The Fairfield County Commissioners awarded these funds to the Fairfield County Health Department to address social determinants of health, including secure housing, and foster an improved quality of life for older residents.

These funds are only available for a limited time. Call the Fairfield County Health Department - Environmental Health Division, at (740) 652-2800 option#3, for more information about this Healthy Aging grant program.



Visit us on Facebook

Welcome to the May 2024 Imagine Newsletter



Imagine

To bring about a vibrant community where people lead lives of greater independence and make meaningful contributions.

Students around Fairfield County are counting down the days until the end of school. They are anxiously awaiting the end of homework and getting up earlier than a parent. I am excited, knowing that there will be no more nothing to do this summer. As a parent, I am thinking about how best to enrich their summer to make sure they don't forget all they have learned. We are excited to be part of a community of students, educational opportunities, and fun to see each of us learning and growing.



David Uhl, Superintendent

Whether you have children or not, I encourage you to get involved in our community through various activities. Go to an event, help out our great library and libraries. Take advantage of our grant program. Fairfield DD will be out and about at events around the county, and I hope we can connect.

David

Vibrant Community Connection

Exceptional Education

Core District is proud to announce the achievement of a 5-star rating through the Ohio Department of Education (ODE). This program recognizes and promotes learning and development in education and child care programs that meet and exceed licensing requirements. ODE-funded programs must participate and uphold a rating of 4 or above to continue receiving funding. Core District is proud to have achieved a 5-star rating in the past and is excited to have reached the highest rating given by the accrediting body. The staff, employees, training and creative power



Our schools want students to learn and grow each day, ensuring that students have access to an outstanding education.

"Building" Collaboration

Project Playhouse, through Habitat for Humanity Southeast Ohio, is a longstanding tradition in our community where volunteers build a playhouse, providing children with a safe place to play and imagine. Recently, a playhouse was constructed by students and volunteers at Saint Mary's School and donated to the playground at Core City School. This year, a unique bond was formed between the two schools as one family has become enrolled at Saint Mary's and a daughter attending Core City. This unique collaboration between three local organizations highlights how connections can create a strong community.



Building Strong Relationships

The most recent installment of our ongoing series features an update provided by Mick Miller on his goals and recent endeavors. The discussion in this episode highlights the importance of collaboration in fostering meaningful relationships that contribute to a richer and more satisfying life.

[Listen today at air.104.5fm.com](#)



Community Partnership Corner

Fairfield DD Staff Represent at PAR Annual Conference

Multifaceted DD employees participated in the Professional Development and Resource Roundtable annually. Participants gained valuable insight from experts across Ohio on current trends to professional in the DD field.



DD has a strong leadership presence within the organization as well with Dawn Butler, ICDP Director, fulfilling the role of Vice President, and David Chouhinterintendent, serving as a Board member.

Community Education

Our multifaceted DD, offering collaboration and establishing connections with valuable resources are integral to our work. We recognize the significance of establishing open lines of communication with other local agencies as a crucial aspect of this process. Service and support teams represent the multifaceted DD to promote service that multifaceted count on and assist service. This group of staff and community included child and adult social workers, as well as administrative staff. Multifaceted DD conducted a series of interviews and then answered questions about how to better collaborate going forward.



Fairfield DD Feature Department



The event takes the provider and community Resource Department collaborate with the service and support team in sharing resource, taking through situation, and identifying opportunities for people to be more independent and involved in their community. The event takes have been assigned to team at the prior contact person for support however, a provider and community Resource team will be working together to train for, share known resource, and deliver training as needed. Additionally, the event are not tied to online event discussion and will be on people taking ownership of their life goal and outcome by supporting a people to existing community resource and assisting people in reaching their full potential.

Upcoming Events

Lancaster Community Days Festival

May 17, 18, and 19, 2024

There will be a line up of event for the whole family at the fairfield county fairground. There will be a huge entertainment, food, craft, and entertainment. [Click here for more information](#)

Rockin' the Block

May 25, 26, and 27, 2024

This weekend long event in Midwayport include concert, a car show, bounce house and much more. [Click here for more information](#)

Mt. Pleasant Photography Club All-Ages Scavenger Hunt

Sunday, May 26, 2024, All day

Participate in the Mt. Pleasant Photography Club artworl scavenger hunt on the road border of the Main Street from Main through Union. Participants will get a chance to win a framed copy of their favorite exhibit photograph. [Click here for more information](#)

Saturday Cinema in Downtown Lancaster

Saturday, June 8, 2024, 8:00 pm

On Saturday, June 8th, Destination Downtown Lancaster will be showing Wonders, a free outdoor movie at the square with the bandstand. People can come our place, enjoy food, and participate in free movie activities starting at 8:00 pm. [Click here for more information](#)



**TO LEARN MORE OR REGISTER FOR EVENTS
VISIT OUR WEBSITE**

www.fairfielddd.com



Fairfield County Board of Developmental Disabilities | 795 College Ave, Lancaster, OH 43130

[Unsubscribe rochelle.menningen@fairfieldcountyohio.gov](mailto:rochelle.menningen@fairfieldcountyohio.gov)

[Update Profile](#) | [Constant Contact Data Notice](#)

Sent by communications@fairfielddd.com powered by



[Try email marketing for free today!](#)

[View a Website](#)

For Immediate Release



Media Contact:

Belle Communication

info@bellecommunication.com

Visit Fairfield County's 2024 Destination Guide Now Available



Lancaster, Ohio Magazine is filled with information and designed to help you discover the best of Fairfield County. The 2024 Destination Guide is available now at the Visitor Center in downtown Lancaster. It is the perfect resource for the community and a great way to learn more.

The Destination Guide features a page of information regarding attractions, events, restaurants, shopping, education, lodging, and more around the area. Readers can enjoy an article about Lancaster's recent designation as a Best Hometown in Ohio Magazine, or take an interactive quiz to determine which of Visit Fairfield County's themed trails is a match for them. The guide is a fun, educational and inspirational resource for anyone

interested in Fairfield County and a great way to learn more about it.

The 2020 Destination Guide cover feature two talented photographers during *Destination Downtown Lancaster's* annual *Wanted to Take a Picture* contest. The cover was chosen by *Visit Fairfield County* to highlight a signature, Best of Lancaster event that captures the essence of the local community and entertainment spirit.

To get your copy of the brand new 2020 Destination Guide, visit the *Visit Fairfield County* visitor center at 128 N. Broad Street in downtown Lancaster between 9 a.m. and 5 p.m., Monday through Friday or download a digital version of the guide in a PDF format on visitfairfieldcount.org, or buy a copy at the visitor center or a guide to be mailed to you.

For additional information, please call *Visit Fairfield County* at 614.885.1234.

To learn more about *Visit Fairfield County*, visit visitfairfieldcount.org, or follow the organization on Facebook <https://www.facebook.com/visitfairfieldcountohio>.

Visit Fairfield County: The Fairfield County Visitors and Convention Bureau is a non-profit destination marketing organization that promotes places to visit and things to do in Fairfield County to visitors and residents alike. The information center is located at 128 N. Broad Street in Lancaster, Ohio.

Visit Fairfield County
128 N. Broad Street, Lancaster, OH 43130
614.885.1234
visitfairfieldcount.org

Connect With Us



Fairfield County Visitors & Convention Bureau | 128 N. Broad Street | Lancaster, OH 43130
US

[Unsubscribe](#) | [Update Profile](#) | [Constant Contact Data Notice](#)



Try email marketing for free today!



FAIRFIELD COUNTY REGIONAL PLANNING COMMISSION

Listen and Learn

May 21, 2024

REGIONAL PLANNING COMMISSION

Established under the Ohio Revised Code but is a community-based organization

Guides long range and current planning activities within the county

Members include the county, cities, villages, townships and citizen representatives

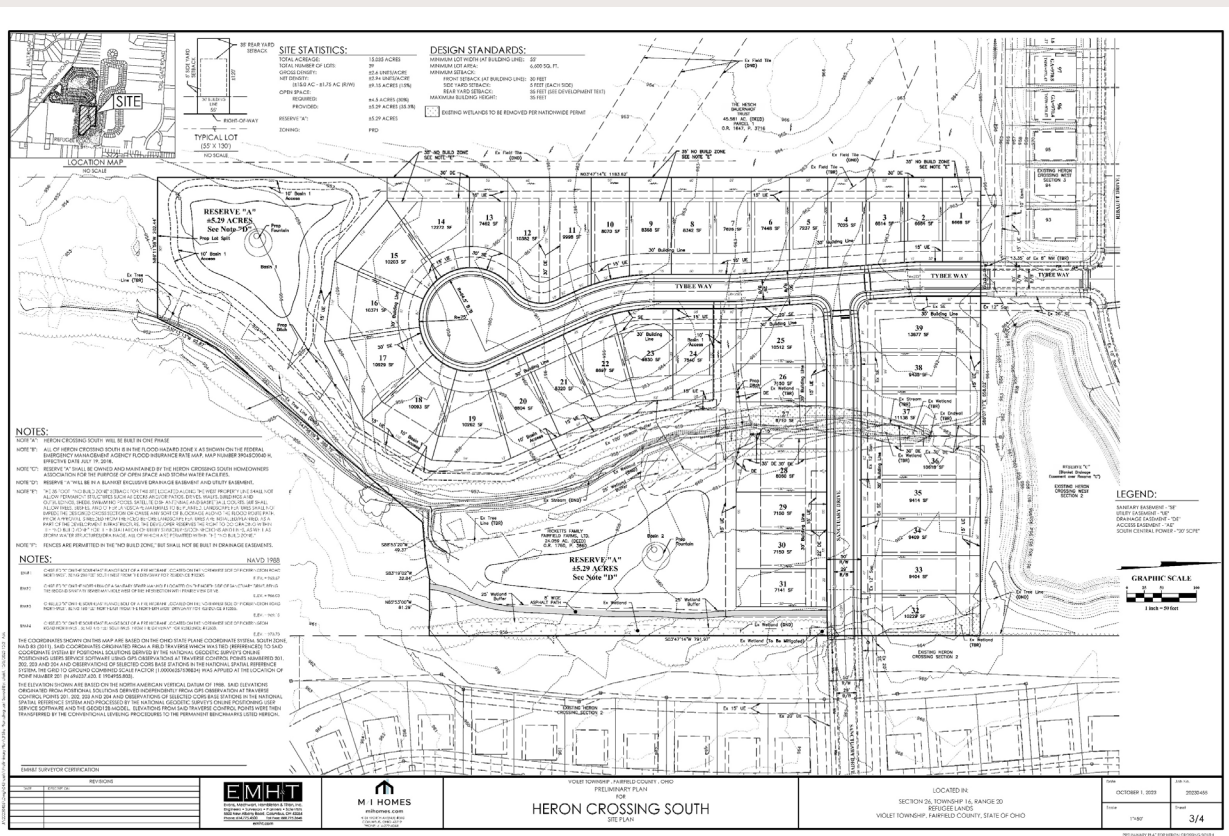
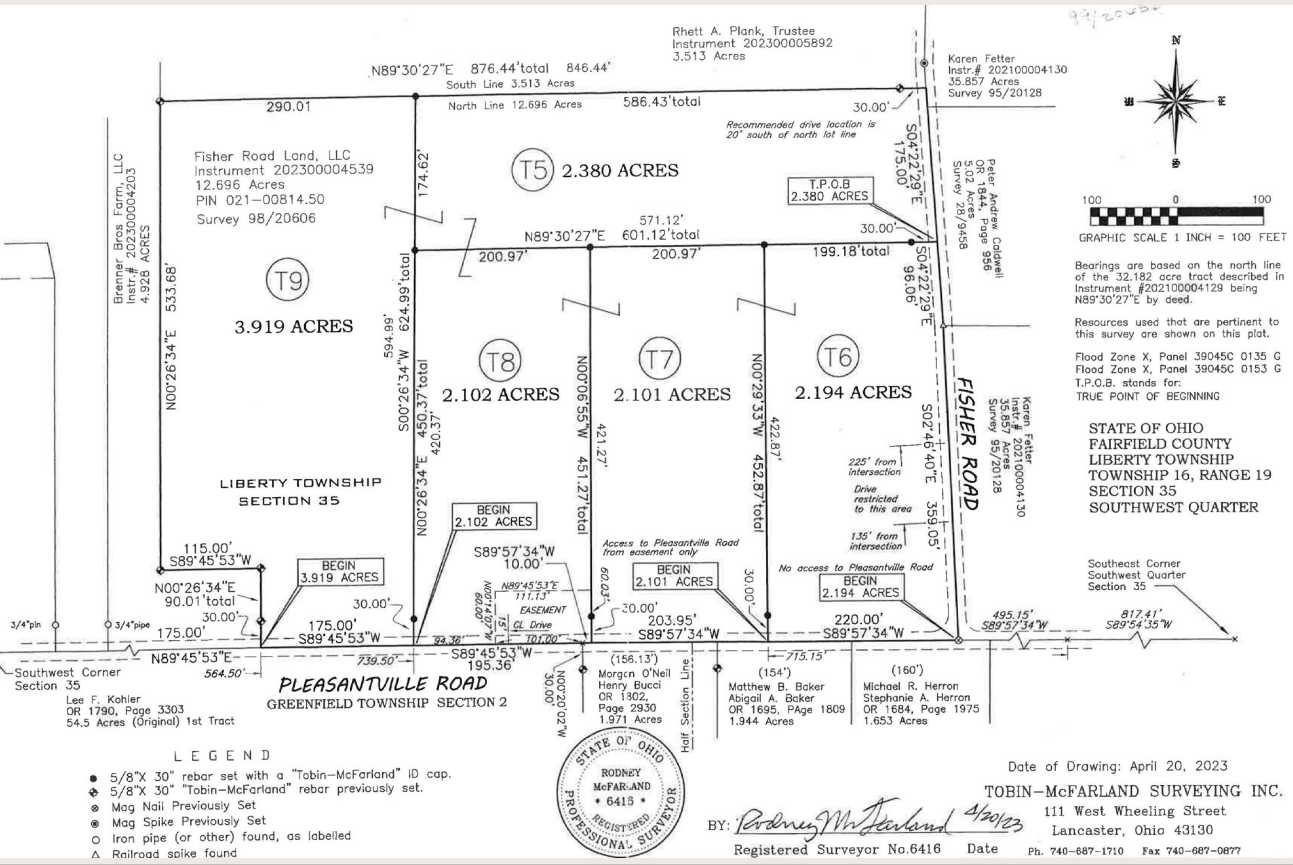

CURRENT PLANNING ACTIVITIES

Administration of the Fairfield County Subdivision Regulations



Date of Drawing: April 20, 2023
RODNEY McFARLAND SURVEYING INC.
 111 West Wheeling Street
 Lancaster, Ohio 43130
 BY: *Rodney McFarland* 4/20/23
 Registered Surveyor No. 6416 Date Ph. 740-687-1710 Fax 740-687-0877

		PRELIMINARY PLAN HERON CROSSING SOUTH SITE PLAN	LOCATED IN SECTION 35, TOWNSHIP 16, RANGE 19 SOUTHWEST QUARTER LIBERTY TOWNSHIP, FAIRFIELD COUNTY, STATE OF OHIO	DATE OCTOBER 1, 2023	SHEET NO. 3/4
--	--	---	---	-------------------------	------------------



CURRENT PLANNING ACTIVITIES

Administration of the Fairfield County Flood Damage Prevention Regulations

BLOOM TOWNSHIP

PLEASANT TOWNSHIP

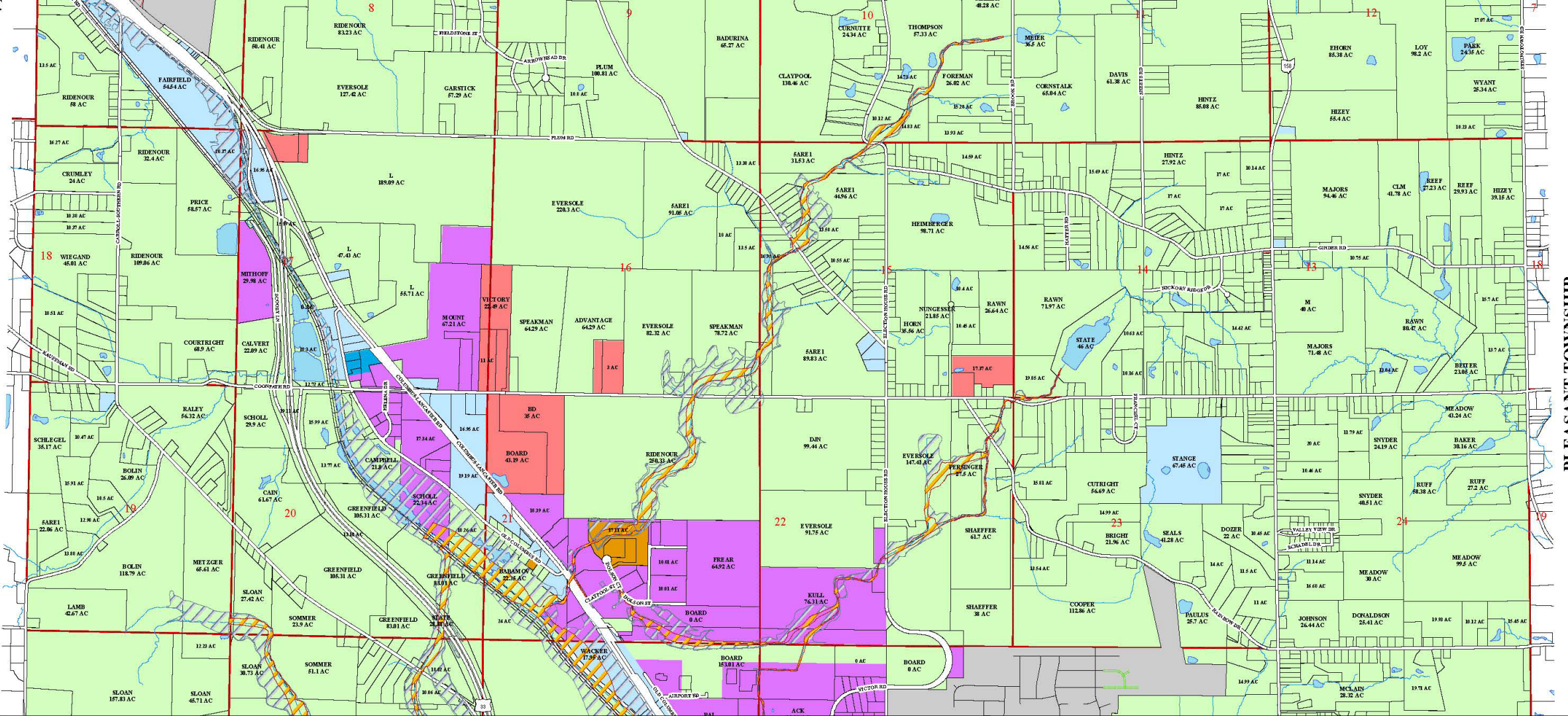

CURRENT PLANNING ACTIVITIES

Zoning Technical Assistance

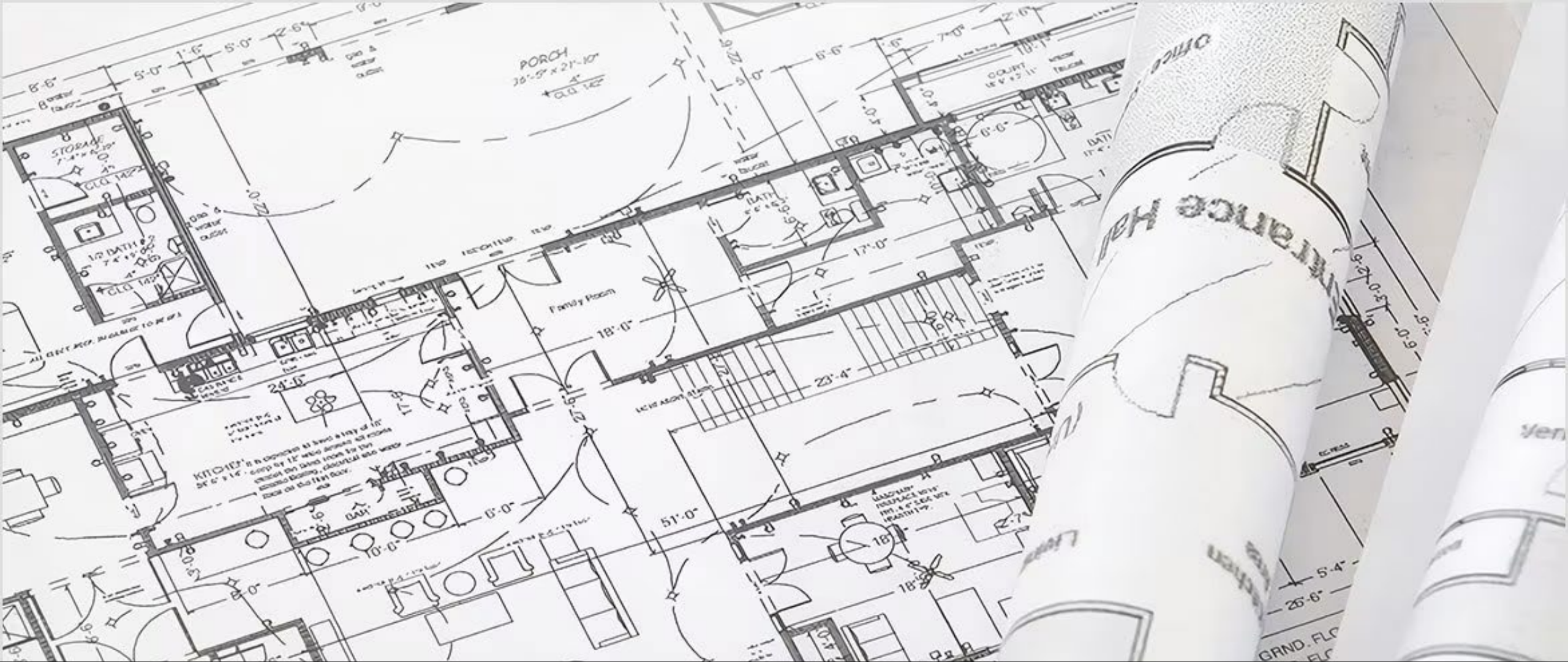

CURRENT PLANNING ACTIVITIES

Administer the Fairfield County Commercial Building Department

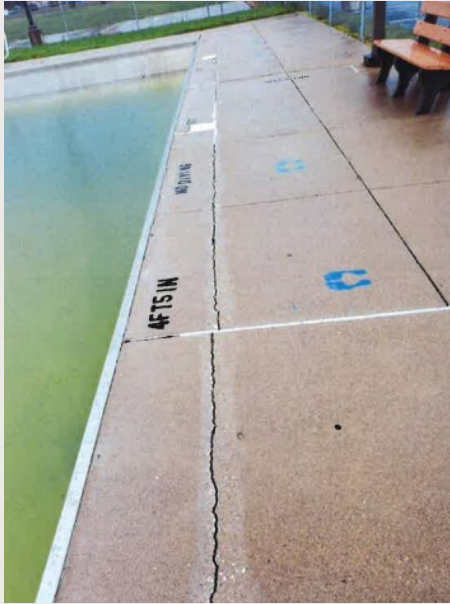

COMMUNITY DEVELOPMENT BLOCK GRANT

FAIR HOUSING



**EQUAL HOUSING
OPPORTUNITY**

- Race
- Color
- Religion
- Sex
- Disability
- Familial Status
- National Origin
- Military Status*

*Ohio

LONG RANGE PLANNING

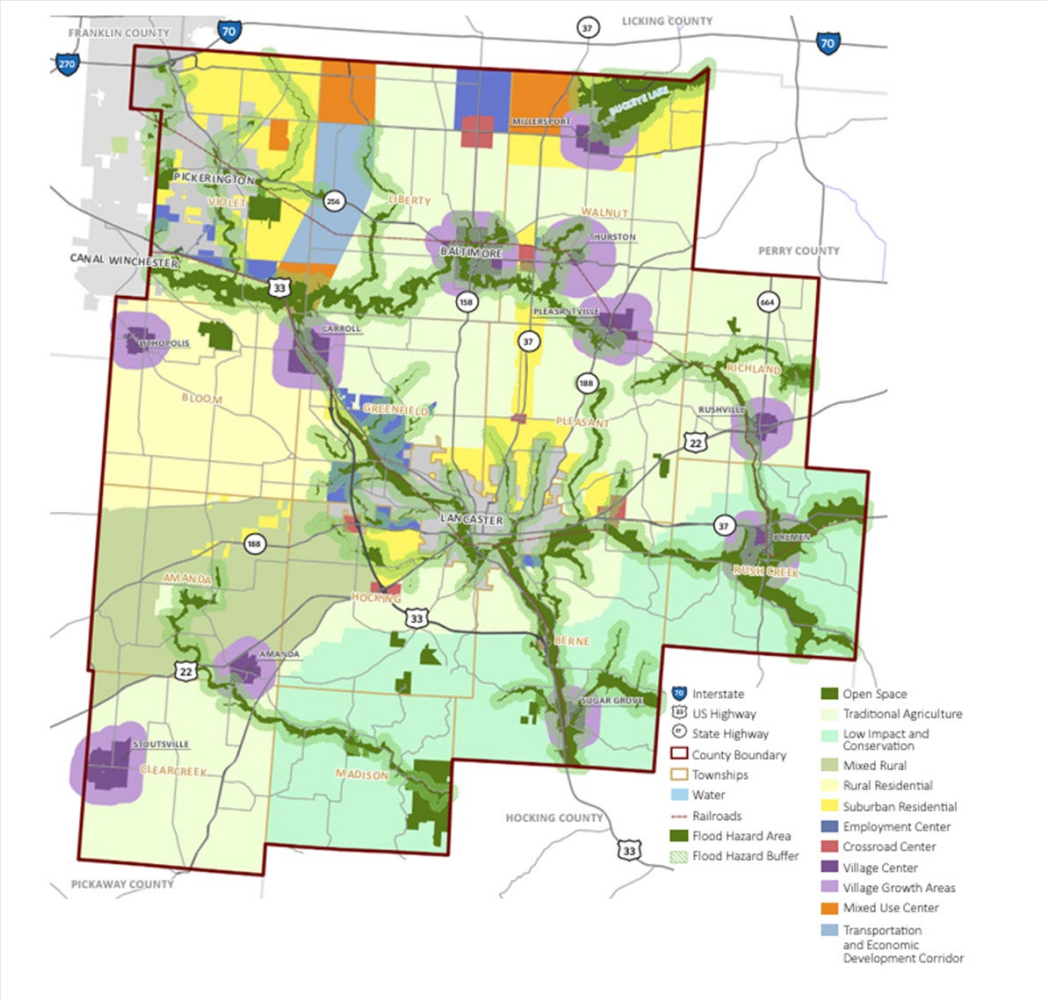
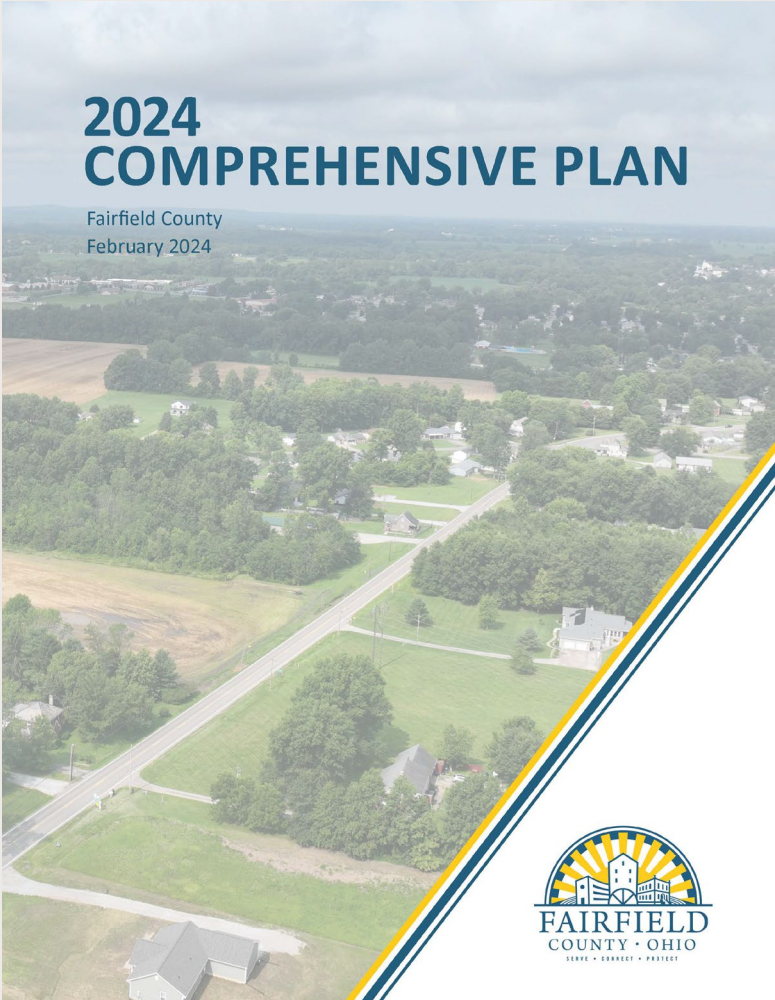

Open Space

Traditional
Agriculture

Low
Impact/Conservation

Mixed Rural

Rural Residential

Suburban Residential

Employment Center

Crossroad Center

Village Center

Village Growth Areas
SF, TF, MF

Mixed Use Center

Transportation &
Economic
Development

LONG RANGE PLANNING

a) Permitted, Special Exception and Accessory Uses

See Section XXX – Permitted, Special Exception, and Accessory Uses for each District.

b) Lot Area, Setback, Height, and Lot Coverage Requirements

Development Standards

Agriculture

Minimum Lot Size (Acres)	X
Maximum Density (utilize net acres)	X
Minimum Frontage (Feet)	X
Minimum Front Setback (Feet)	X
Maximum Front Setback (Feet)	X
Minimum Side Setback (Feet)	X
Minimum Rear Setback (Feet)	X
Maximum Height (Feet)	X
Maximum Lot Coverage (Percent)	X

Projection into required setback

Cornices, canopies, eaves (roof overhang), fireplaces-chimneys, bay window, porch, stoop, or other similar architectural features may project into a required setback up to two feet.

Exemptions from required side and rear setbacks.

Swimming pools, tennis courts, clotheslines, barbecue pits, playground equipment, portable or permanent dog run, house or kennel and similar structures customary and ancillary to the primary residential use of the property may be placed in a required minimum side or rear setback, but in no case shall such uses be closer than ten (10) feet from a side or rear lot line.

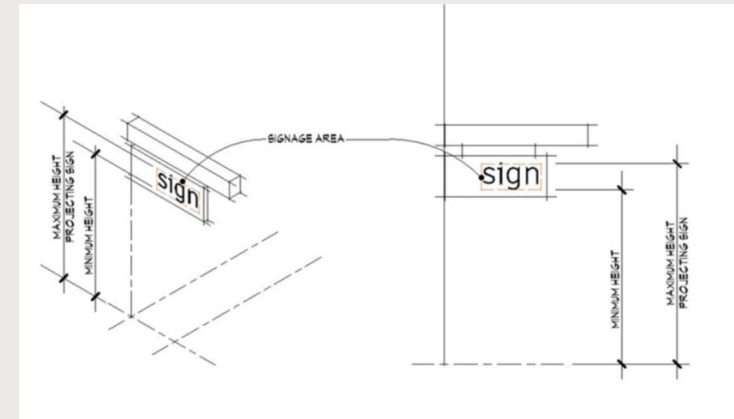
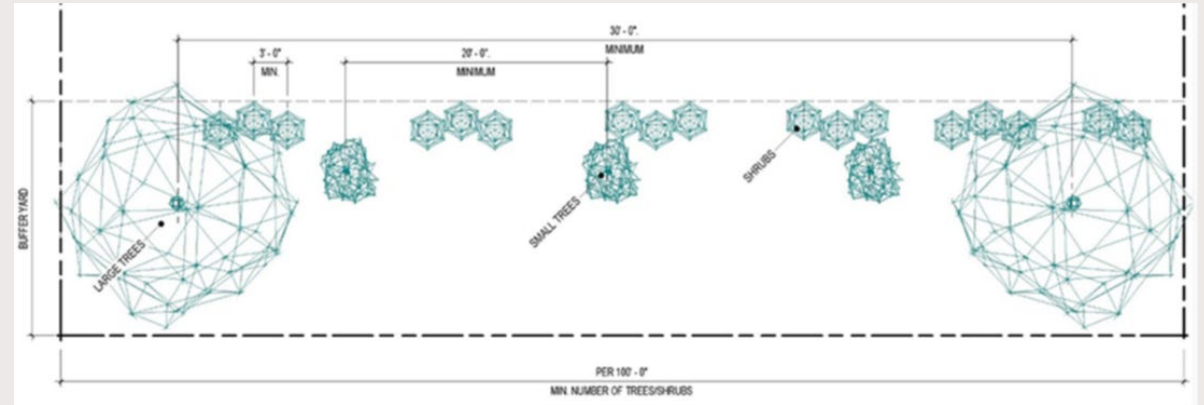

MODEL ZONING CODE



REGIONAL PLANNING COMMISSION MEETINGS

- First Tuesday of every month
- 6:00 p.m.
- Fairfield County Record's Center

138 West Chestnut St.

Lancaster, OH

43130

Contact Information:

Phone: 740-652-7110

www.co.fairfield.oh.us/rpc

QUESTIONS?



Airport Update 5/21/24

Since we last met

- Completed Master Plan and Drainage Study
- Developed and sought funds for Entrance Road
- Awarded \$366,000 grant for obstruction removal
- Water/Sewer Upgrade
- Developed new Land Lease

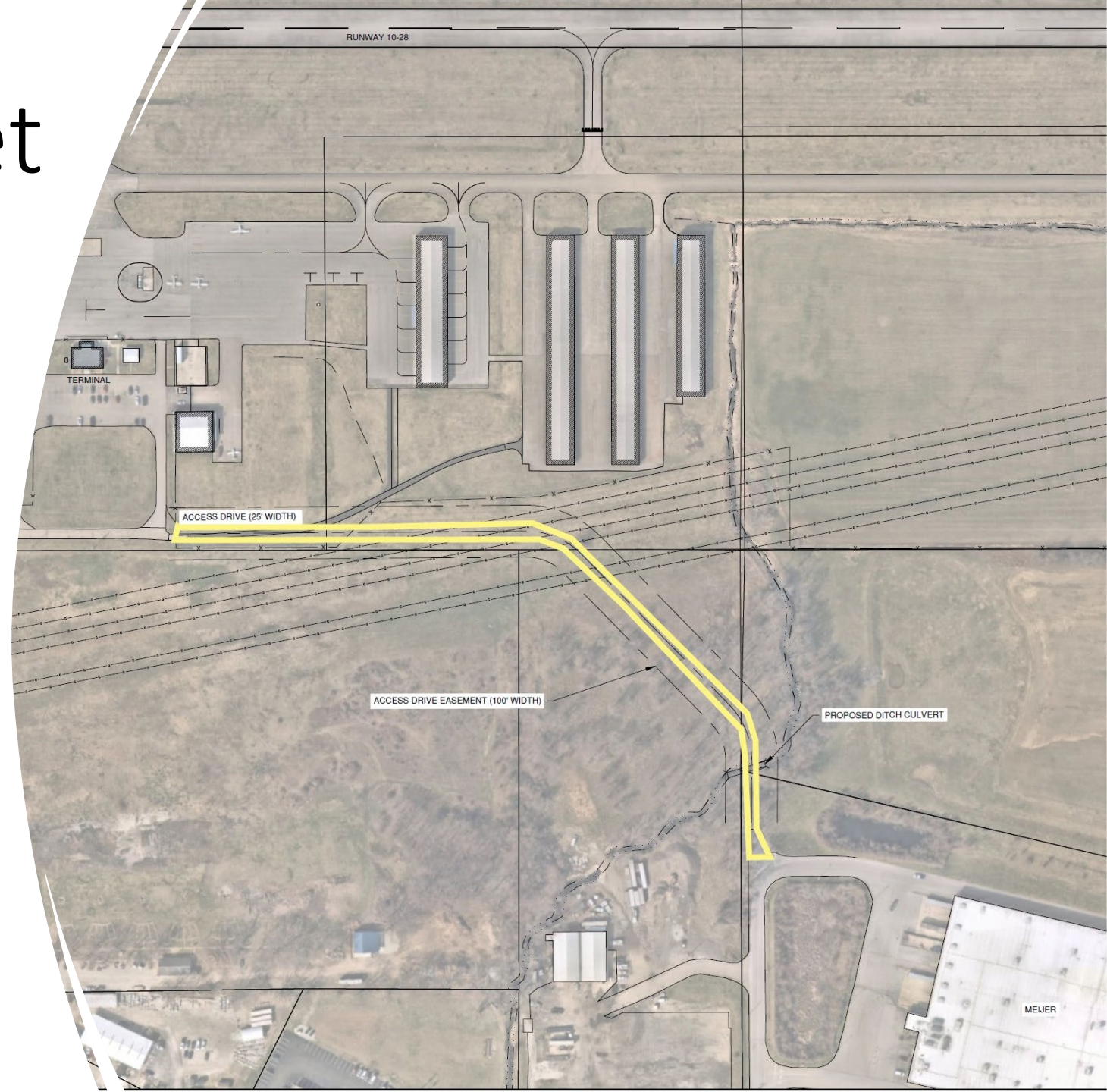

Water/Wastewater upgrade and new service

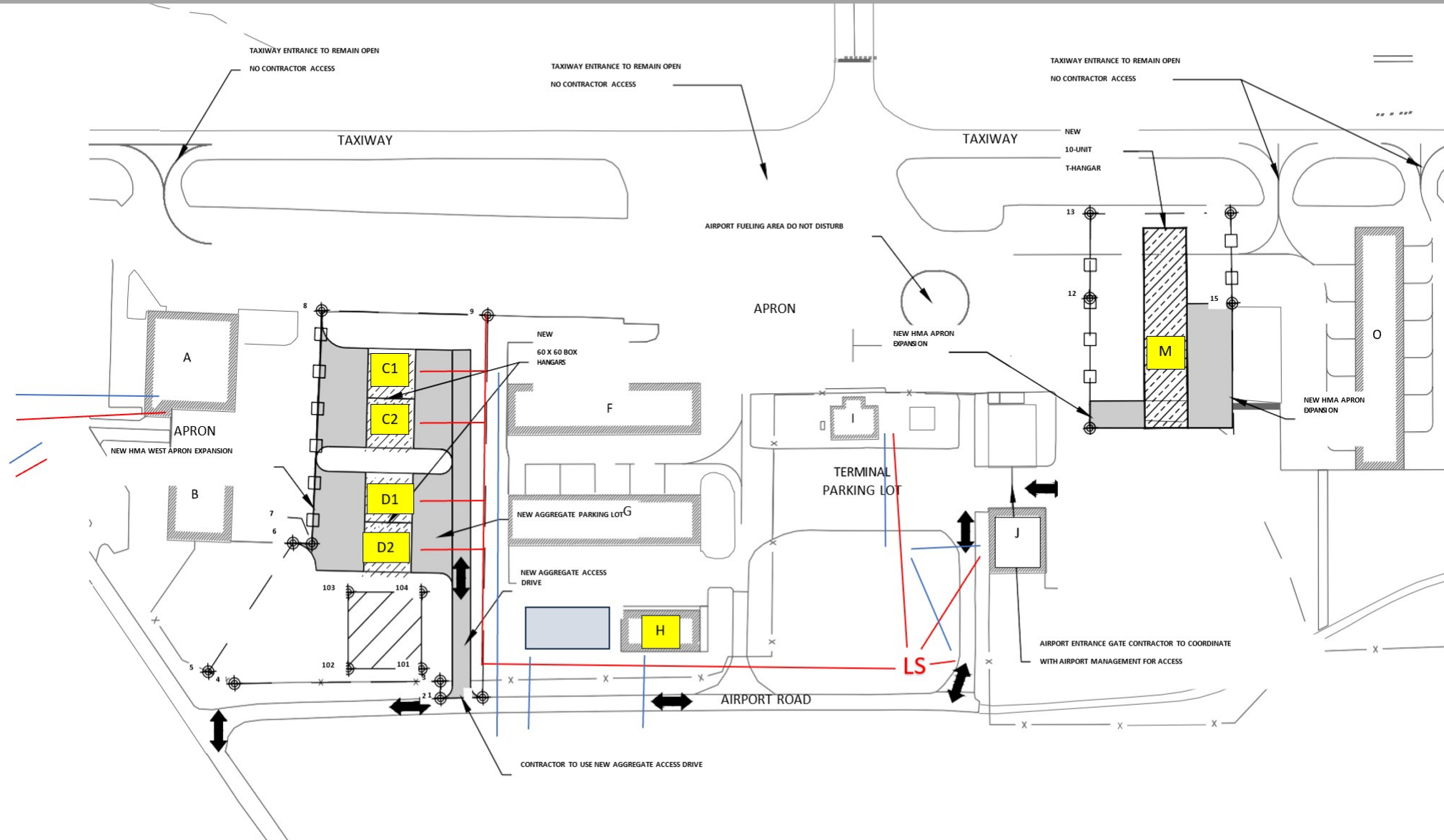



2U-Box
Hangar
Base Bid

10 U T-
Hangar
W/
Public
RR

New Apron
(grant funding)

Gravel
Parking

2U-Box
Hangar
Alternate

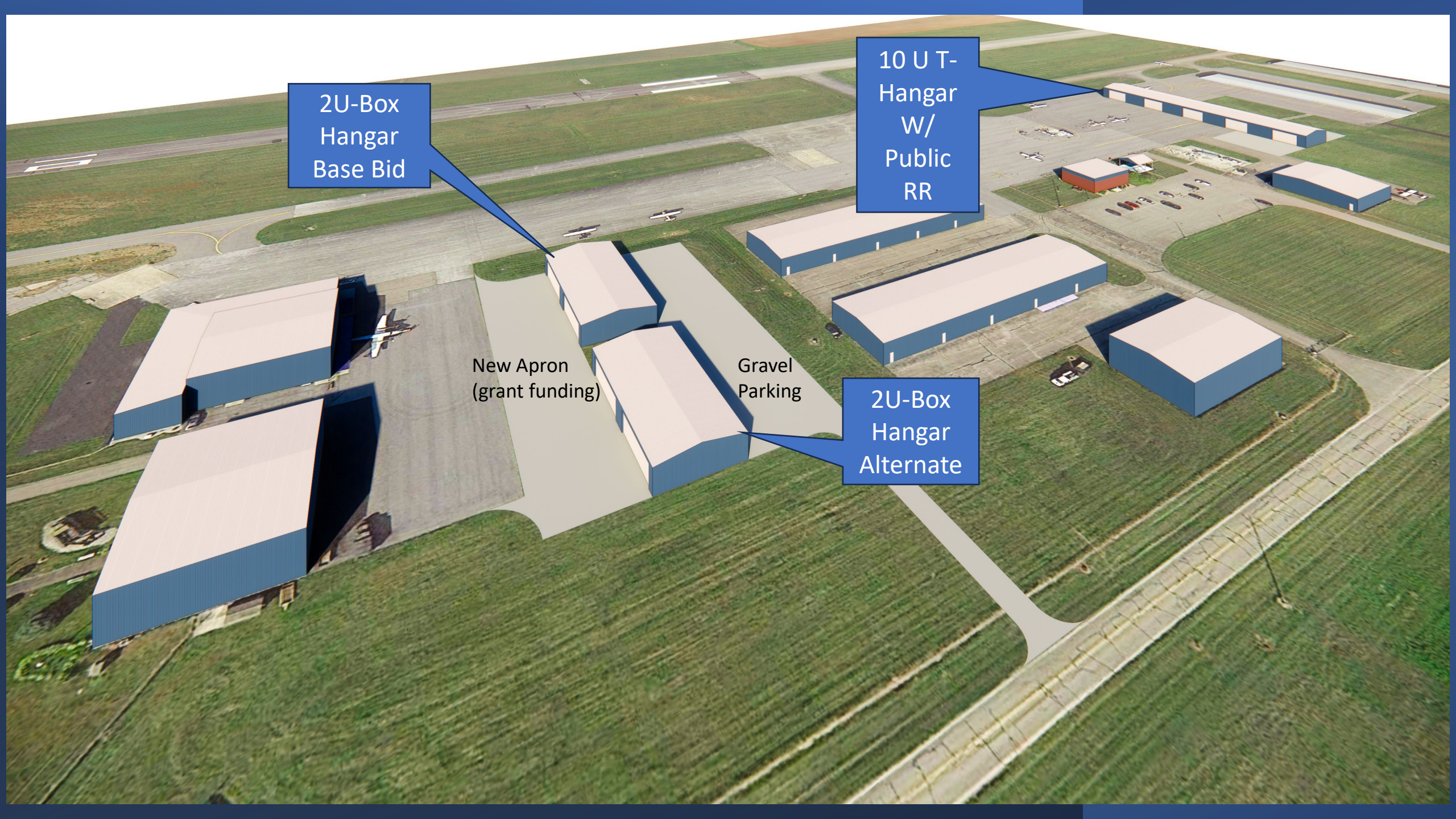

Estimate vs As Bid

Estimated construction cost May 22

10 Unit T-Hangar \$1,695,400

4 Box Hangar \$2,693,750

Total \$4,389,150

Budget allocated \$5,000,000

As Bid construction cost May 24

10 Unit T-Hangar \$2,092,795

 +\$397,395- 18%

4 Box Hangar \$3,549,872

 +856,122 – 24%

Total \$5,642,667

 +1,253,517 – 22%

Budget increase need \$833,000

10 unit T-Hangar

- 10 units for general aviation
- Closest proximity to fuel, terminal and access.
- Separate Utilities
- Currently more than ~~20~~ 27 people have put deposits on “T-Hangars” at the Airport
- Since last update 8 hangars have turned over and the wait list grew to 27

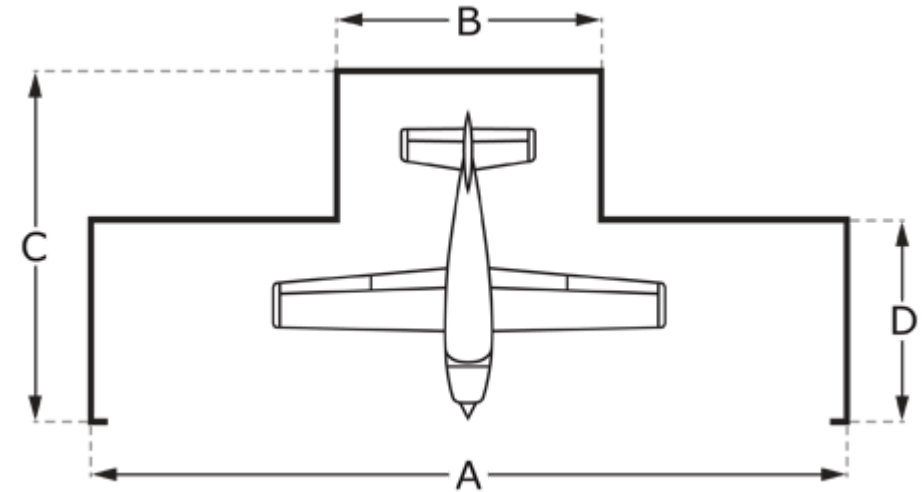

File: \\C:\Users\cmt\Documents\19065003.dwg, Mail: \\c:\users\cmt\Documents\19065003.dwg and West Sides.dwg
 Date: Tuesday, March 17, 2022 9:24:23 AM

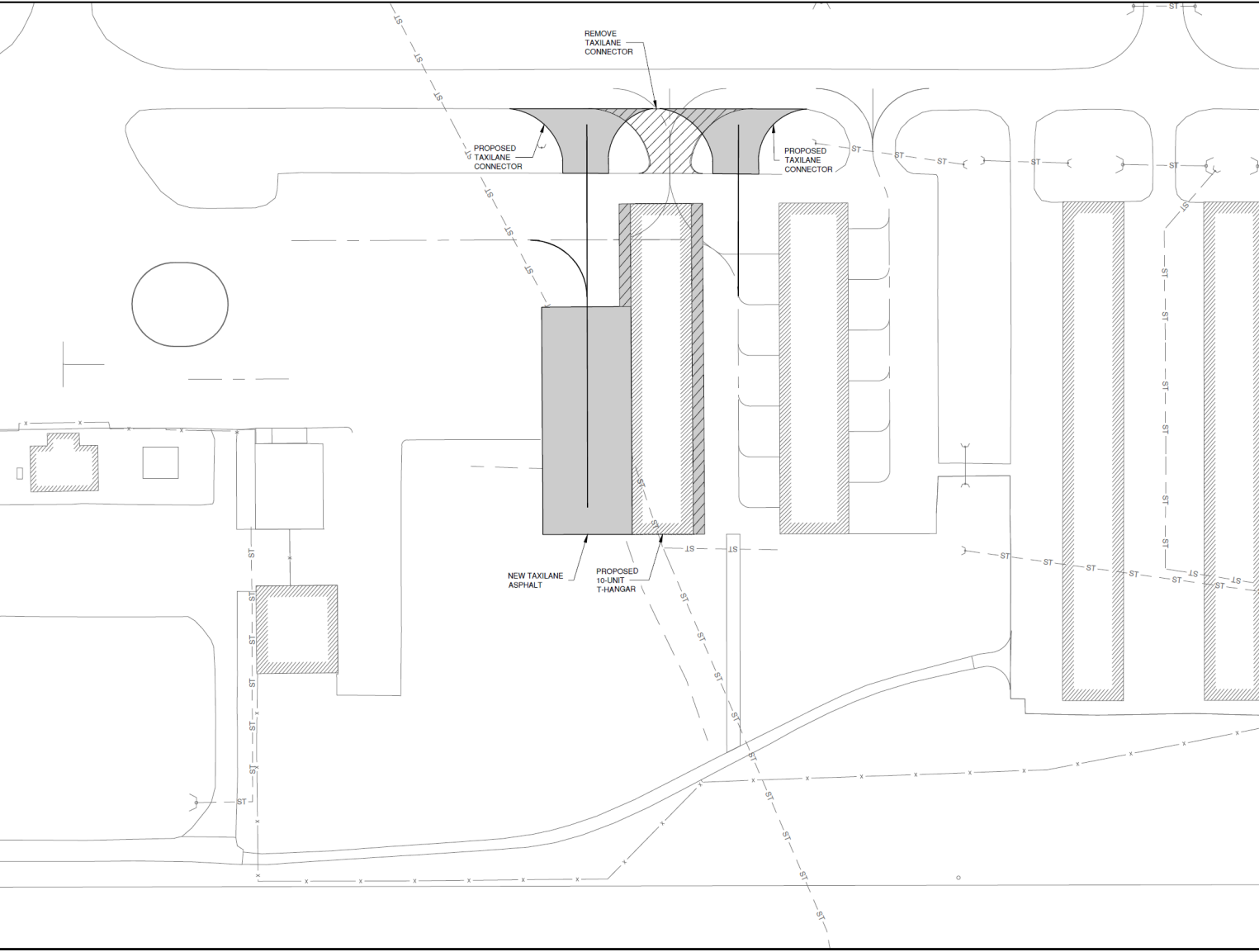





EXHIBIT
MARCH 17, 2022

MASTER PLAN UPDATE

OWNER

FAIRFIELD COUNTY AIRPORT
AUTHORITY
FAIRFIELD COUNTY AIRPORT
LANCASTER, OHIO

MARK	DATE	DESCRIPTION

AP PROJECT NO: N/A
STATE PROJECT NO: N/A
CMT PROJECT NO: 19065003.00
CAD DWG FILE EAST AND WEST SIDES DWG
DESIGNED BY: CMT
DRAWN BY: KEF
CHECKED BY: BDC
APPROVED BY: BDC
COPYRIGHT:

SHEET TITLE

EAST T-HANGAR

SHEET 1 OF 1

ROI on 10-unit T-Hangar at 95% Occupancy w/o interest

T-Hangars	Construction Cost Est	Construction As Bid (apparent low)
Construction Cost	\$ 1,694,500	\$ 2,092,795
Hangars	10	10
Monthly Lease Rate	\$ 450	\$ 450
Annual Lease Revenue per Hangar	\$ 5,400	\$ 5,400
Total Annual Lease Revenue	\$ 54,000	\$ 54,000
Annual Increase	3.0%	3.0%
5-Year Revenue	\$ 272,359	\$ 272,359
10-Year Revenue	\$ 588,097	\$ 588,097
15-Year Revenue	\$ 954,124	\$ 954,124
20-Year Revenue	\$ 1,378,450	\$ 1,378,450
25-Year Revenue	\$ 1,870,360	\$ 1,870,360
30-Year Revenue	\$ 2,440,619	\$ 2,440,619
35-Year Revenue	\$ 2,829,346	\$ 2,829,346

Commercial Box Hangars

- 4 – 3600 sqft box hangars with restroom and office facilities.
- Door opening to support “critical aircraft” classified as a midsize business jet. A current Unmet Need.
- Build to Suite opportunity after project kickoff.
- Existing potential of lessees now.
- Create proposal process to lease. Applicants demonstrate how occupying drives economy.



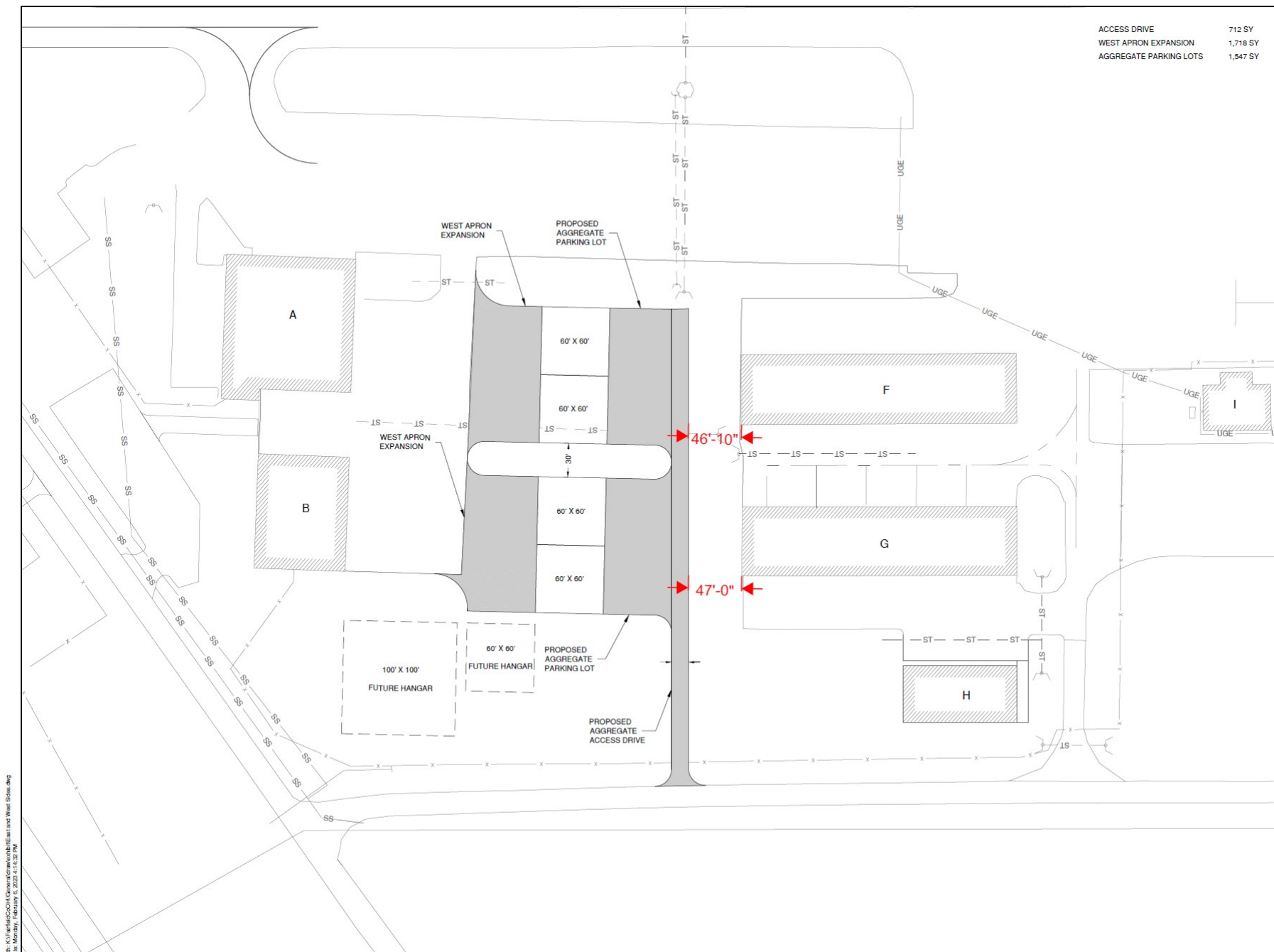

ACCESS DRIVE 712 SY
WEST APRON EXPANSION 1,718 SY
AGGREGATE PARKING LOTS 1,547 SY

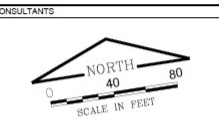

EXHIBIT
FEBRUARY 6, 2023

OWNER

FAIRFIELD COUNTY AIRPORT AUTHORITY
FAIRFIELD COUNTY AIRPORT
LANCASTER, OHIO

Path: K:\FairfieldCOA\ExhibitDrawings\BIRW and West Sides.dwg
Date: Monday, February 6, 2023 4:14:52 PM

MARK	DATE	DESCRIPTION

AIP PROJECT NO: N/A
STATE PROJECT NO: N/A
CMT PROJECT NO: 19065003.00
CAD DWG FILE: EAST AND WEST SIDES.DWG
DESIGNED BY: CMT
DRAWN BY: KEF
CHECKED BY: BDC
APPROVED BY: BDC
COPYRIGHT:

SHEET TITLE

WEST SIDE HANGARS

ROI on 4-60x60 Commercial hangar w/o interest

Box Hangars	Construction Cost	As Bid Cost
Construction Cost	\$ 2,693,750	\$3,549,872
60x60 Hangar		
Hangars	4	4
Monthly Lease Rate	\$ 1,000	\$ 1,500
Annual Lease Revenue per Hangar	\$ 12,000	\$ 18,000
Total Annual Lease Revenue	\$ 48,000	\$ 72,000
Annual Increase		3.0%
5-Year Revenue	\$ 305,806	\$ 382,258
10-Year Revenue	\$ 660,319	\$ 825,399
15-Year Revenue	\$ 1,071,297	\$ 1,339,122
20-Year Revenue	\$ 1,547,734	\$ 1,934,667
25-Year Revenue	\$ 2,100,054	\$ 2,625,067
30-Year Revenue	\$ 2,740,344	\$ 3,425,430
35-Year Revenue	\$ 3,176,810	\$ 3,971,012

15 Year
~~\$1,389,150~~ \$2,000,000 Cash
 \$3,000,000 Financed

Debt Service Payments Current Est: \$297,000 average

- Year 1
- Hangar Revenue estimate: \$108,900
- General Fund Contribution estimate: \$205,006
- Year 35
- Hangar Revenue estimate: \$336,844
- General Fund Contribution estimate: \$0
- Total Cost = \$7,055,000 (2,600,000 cash+\$4,455,000 debt)
- Total Finance Cost= ~~\$1,708,590~~ \$1,412,254.01
- Total Revenue to GF over 35 Y = ~~\$1,875,731~~ \$2,999,975

Year	Lease Revenue A+B	GF contribution	Debt Pay Ave
1	\$ 123,300	\$ (173,700)	\$ 297,000.00
2	\$ 126,999	\$ (170,001)	\$ 297,000.00
3	\$ 130,809	\$ (166,191)	\$ 297,000.00
4	\$ 134,733	\$ (162,267)	\$ 297,000.00
5	\$ 138,775	\$ (158,225)	\$ 297,000.00
6	\$ 142,938	\$ (154,062)	\$ 297,000.00
7	\$ 147,227	\$ (149,773)	\$ 297,000.00
8	\$ 151,643	\$ (145,357)	\$ 297,000.00
9	\$ 156,193	\$ (140,807)	\$ 297,000.00
10	\$ 160,879	\$ (136,121)	\$ 297,000.00
11	\$ 165,705	\$ (131,295)	\$ 297,000.00
12	\$ 170,676	\$ (126,324)	\$ 297,000.00
13	\$ 175,796	\$ (121,204)	\$ 297,000.00
14	\$ 181,070	\$ (115,930)	\$ 297,000.00
15	\$ 186,502	\$ (110,498)	\$ 297,000.00
16	\$ 192,097	\$ 192,097	\$ -
17	\$ 197,860	\$ 197,860	\$ -
18	\$ 203,796	\$ 203,796	\$ -
19	\$ 209,910	\$ 209,910	\$ -
20	\$ 216,207	\$ 216,207	\$ -
21	\$ 222,694	\$ 222,694	\$ -
22	\$ 229,374	\$ 229,374	\$ -
23	\$ 236,256	\$ 236,256	\$ -
24	\$ 243,343	\$ 243,343	\$ -
25	\$ 250,644	\$ 250,644	\$ -
26	\$ 258,163	\$ 258,163	\$ -
27	\$ 265,908	\$ 265,908	\$ -
28	\$ 273,885	\$ 273,885	\$ -
29	\$ 282,101	\$ 282,101	\$ -
30	\$ 290,565	\$ 290,565	\$ -
31	\$ 299,281	\$ 299,281	\$ -
32	\$ 308,260	\$ 308,260	\$ -
33	\$ 317,508	\$ 317,508	\$ -
34	\$ 327,033	\$ 327,033	\$ -
35	\$ 336,844	\$ 336,844	\$ -
Total	\$ 7,454,975	\$ 2,999,975	\$ 4,455,000.00

1998-2028 Sales Tax

Accounting period	Nov	Dec	Jan	Feb	Mar	Apr	May	Jun	Jul	Aug	Sep	Oct	Total	
Actual Sales Mth	Oct	Nov	Dec	Jan	Feb	Mar	Apr	May	Jun	Jul	Aug	Sep		
Paid Out Sales Mth (ERP)	Jan	Feb	Mar	Apr	May	Jun	Jul	Aug	Sep	Oct	Nov	Dec	Total	YOY % Change
1998	625,428	625,428	719,073	547,322	561,371	666,416	593,404	724,648	751,083	703,219	681,607	618,403	7,817,400	
1999	657,897	717,170	876,039	577,369	671,203	688,353	731,728	777,431	781,161	769,846	1,012,161	684,083	8,944,440	14.4%
2000	755,159	718,864	974,212	512,750	834,597	654,420	894,968	778,463	793,014	878,159	761,757	790,563	9,346,926	4.5%
2001	664,322	804,344	978,984	607,672	732,002	817,502	823,409	825,936	768,031	771,395	690,052	851,334	9,334,984	-0.1%
2001 sales tax revenue impacted by 9/11 tragedy														
2002	730,658	731,624	981,860	670,382	777,203	914,764	827,811	740,520	833,021	906,163	885,007	856,718	9,855,731	5.6%
2003	772,068	823,287	990,687	692,883	593,339	937,425	754,394	878,765	954,111	774,672	888,092	816,480	9,876,203	0.2%
2004	799,633	898,085	1,052,974	675,196	738,185	960,111	811,136	895,680	872,111	903,939	860,357	782,645	10,250,052	3.8%
2005	926,106	861,098	1,149,122	725,719	817,400	888,205	899,788	920,243	1,015,090	935,066	915,824	829,075	10,882,735	6.2%
2006	800,452	967,645	1,178,266	892,316	863,719	884,728	913,317	867,449	988,573	923,246	878,268	911,932	11,069,910	1.7%
2007	838,721	871,197	1,354,528	826,456	849,253	975,686	977,960	871,975	1,043,345	841,742	861,899	945,081	11,257,843	1.7%
2008	814,929	964,143	1,308,987	742,435	827,638	1,000,446	940,768	978,406	1,120,611	962,304	940,066	969,431	11,570,163	2.8%
2009	879,734	893,651	1,347,421	774,025	829,419	946,986	894,012	1,019,233	1,049,559	951,848	889,490	916,394	11,391,771	-1.5%
2009 sales tax revenue impacted by the great recession.														
2010	887,254	1,162,923	1,339,323	1,102,139	1,185,143	1,390,629	1,208,103	1,470,249	1,468,452	1,277,519	1,328,907	1,364,823	15,185,464	33.3%
YOY increase includes 1/4 point increase in sales tax.														
2011	1,236,349	1,397,846	1,839,288	1,156,127	1,286,106	1,402,975	1,306,597	1,456,941	1,301,891	1,443,660	1,306,381	1,342,798	16,476,960	8.5%
2012	1,322,775	1,491,042	1,888,126	1,224,544	1,381,868	1,505,374	1,349,342	1,579,835	1,517,628	1,425,024	1,480,711	1,357,146	17,523,415	6.4%
2013	1,343,072	1,524,817	1,890,000	1,323,030	1,415,445	1,523,003	1,517,670	1,679,889	1,597,198	1,513,717	1,493,619	1,493,904	18,315,364	4.5%
2014	1,366,110	1,542,382	1,973,853	1,310,143	1,425,847	1,642,808	1,507,871	1,736,452	1,788,567	1,525,246	1,536,823	1,637,463	18,993,565	3.7%
2015	1,544,599	1,697,286	2,068,410	1,411,499	1,602,856	1,733,690	1,569,737	1,815,498	1,874,355	1,683,700	1,757,591	1,641,079	20,400,299	7.4%
2016	1,638,636	1,727,807	2,320,990	1,465,832	1,609,982	1,784,482	1,668,224	1,833,805	1,822,791	1,738,392	1,721,738	1,665,119	20,997,798	2.9%
2017	1,685,613	1,774,968	2,213,391	1,602,015	1,731,030	1,831,718	1,732,304	1,912,204	1,950,642	1,778,012	1,605,224	1,787,997	21,605,116	2.9%
2018	1,615,273	1,789,901	2,368,984	1,547,767	1,544,431	1,847,292	1,730,387	1,827,911	1,855,921	1,716,332	1,751,273	1,816,057	21,411,529	-0.9%
The S&P 500 in December 2018 fell more than 9% as investors feared a central bank ready to tighten monetary policy, a slowing economy, and an intensifying trade war between the U.S. and China. It marked the worst December since 1931.														
2019	1,666,146	1,847,208	2,307,301	1,536,075	1,583,302	1,840,694	1,844,059	1,867,495	2,065,761	1,757,111	1,861,851	1,917,097	22,094,100	3.2%
2020	1,854,358	1,909,897	2,444,278	1,660,892	1,626,057	1,600,463	1,557,434	2,069,932	2,171,563	1,973,472	2,037,750	1,982,538	22,888,634	3.6%
2021	1,993,692	2,002,315	2,425,745	1,886,350	1,980,821	2,578,358	2,383,697	2,354,940	2,528,056	2,201,394	2,225,312	2,196,807	26,757,487	16.9%
2022	2,252,866	2,360,846	2,778,453	1,953,870	2,132,796	2,490,400	2,377,662	2,559,950	2,464,658	2,377,762	2,498,078	2,420,503	28,667,845	7.1%
2023	2,364,568	2,530,832	2,860,528	2,271,055	2,235,183	2,451,178	2,480,489	2,469,739	2,500,807	2,461,952	2,384,590	2,471,013	29,481,934	2.8%
2024 (BDG)	2,267,275	2,463,754	2,852,676	2,219,695	2,129,413	2,502,054	2,430,852	2,600,023	2,705,049	2,471,416	2,531,138	2,526,656	29,700,000	0.7%
2025 (Est)	2,384,426	2,508,930	3,033,542	2,188,932	2,245,041	2,567,247	2,494,190	2,667,769	2,775,532	2,535,811	2,597,089	2,592,490	30,591,000	3.0%
2026 (Est)	2,455,958	2,584,198	3,124,548	2,254,600	2,312,392	2,644,265	2,569,016	2,747,802	2,858,798	2,611,885	2,675,002	2,670,265	31,508,730	3.0%
2027 (Est)	2,529,637	2,661,724	3,218,285	2,322,238	2,381,764	2,723,593	2,646,086	2,830,236	2,944,562	2,690,242	2,755,252	2,750,373	32,453,992	3.0%
2028 (Est)	2,605,526	2,741,576	3,314,833	2,391,905	2,453,217	2,805,300	2,725,469	2,915,143	3,032,899	2,770,949	2,837,909	2,832,884	33,427,612	3.0%
2029 (Est)	2,683,692	2,823,823	3,414,278	2,463,662	2,526,813	2,889,459	2,807,233	3,002,597	3,123,886	2,854,078	2,923,046	2,917,871	34,430,440	3.0%

REGULAR MEETING #21 - 2024
FAIRFIELD COUNTY COMMISSIONERS' OFFICE
MAY 21, 2024

AGENDA FOR TUESDAY, MAY 21, 2024

- 9:00 AM Review
- 9:30 AM Executive Session to Discuss Personnel Related Matters
- Regular Meeting
- Pledge of Allegiance
- Announcements
- Approval of Minutes for May 14, 2024
- Approval of Minutes for May 14, 2024, Leadership Conference
- Commissioners
- 2024-05.21.a A Resolution to Establish the Ad Hoc Member to the Ohio Power Siting Board [Commissioners]
- 2024-05.21.b A Resolution Approving the Co-Sponsorship Agreement between the Fairfield County Board of Commissioners and the Fairfield County Airport Authority Board [Commissioners]
- 2024-05.21.c A Resolution to Approve a Fund-to-Fund Transfer from the General Fund #1001 to the Flexible Spending Account Fund #7680 [Commissioners]
- 2024-05.21.d A resolution approving an account to account transfer in a major object expense category for the Safety & Security Budget, General Fund# 1001. [Commissioners]
- Fairfield County Auditor- Finance
- 2024-05.21.e A Resolution Authorizing a Fund-to-Fund Transfer, Auditor, Fund #1080 [Auditor- Finance]
- Fairfield County Economic & Workforce Development
- 2024-05.21.f A Resolution to Amend Resolution 2022-09.27.k, Which Established the Fairfield County Route 33 Community Reinvestment Area (CRA); and the Housing Officer, Community Reinvestment Housing Council, and Tax Incentive Review Council (TIRC) for the Aforementioned CRA [Economic & Workforce Development]
- 2024-05.21.g A Resolution Authorizing the Approval of Repayment of an Advance to the General Fund, Fund #2881 EV Charging Station Fund [Economic & Workforce Development]

Fairfield County Engineer

2024-05.21.h A Resolution to Approve an Agreement between Fairfield County and American Structurepoint, Inc. [Engineer]

2024-05.21.i A Resolution to Approve the Construction Drawings for the Fairfield County Engineer's Salt Barn Storage Facility Project [Engineer]

Fairfield County Facilities

2024-05.21.j A Resolution Authorizing the Approval of a Contract Award for the Replacement of Carpet Flooring, Hall of Justice Building [Facilities]

Fairfield County Family and Children First Council

2024-05.21.k A Resolution to Approve Additional Appropriations by Appropriating from Unappropriated into a Major Expense Object Category, Fund #7521 [Family and Children First Council]

2024-05.21.l A resolution to approve additional appropriations by appropriating from unappropriated into a major expense object category – Fund #7521 – Family Adult Children First [Family and Children First Council]

2024-05.21.m A Resolution Approving an Account-to-Account Transfer into a Major Expenditure Object Category, Fund #7521 [Family and Children First Council]

Fairfield County Human Resources

2024-05.21.n A Resolution to Approve a Plan Agreement with the County Commissioners Association of Ohio for Inclusion, the Workers' Compensation Group Retrospective Rating Plan Program [Fairfield County Human Resources]

Fairfield County Job and Family Services

2024-05.21.o A Resolution Authorizing the Approval of a Shared Family Foster Home Agreement by and between Fairfield County Job & Family Services, Child Protective Services Division and South Central Ohio Job and Family Services and Fairfield County Protective Services [JFS]

2024-05.21.p A Resolution to Approve a Memo Expense/Memo Receipt for the Costs of Birth Certificates Paid to Fairfield County Health Departments as a Memo Expenditure for Fund #2072 Public Children's Services [JFS]

2024-05.21.q A resolution to approve additional appropriations by appropriating from unappropriated into a major expense object category – Fund # 2599 – Workforce Fund - Fairfield County JFS [JFS]

Fairfield County Juvenile/Probate Court

2024-05.21.r A Resolution Authorizing the Approval of Amendment #2 to the FY24 Grant Agreement between Fairfield County Juvenile Court and Ohio Department of Youth Services [Juvenile/Probate Court]

Fairfield County Law Library

2024-05.21.s A Resolution to Appropriate from Unappropriated Funds for the Fairfield County Law Library Resources Board, Fund 2761 [Law Library]

Fairfield County Regional Planning Commission

2024-05.21.t A Resolution to Approve Conditional Acceptance of Chesapeake Section 1 Subdivision [Regional Planning Commission]

Fairfield County Sheriff

2024-05.21.u A Resolution Approving the Disposal of Thirteen Disabled Vehicles [Sheriff]

2024-05.21.v A Resolution Approving an Account-to-Account Transfer into a Major Expenditure Object Category [Sheriff]

2024-05.21.w A resolution authorizing the approval of repayment of an advance to the General Fund from Fund 2503 Police Revolving [Sheriff]

2024-05.21.x A resolution authorizing the approval of repayment of an advance to the General Fund from Fund 2593 Concealed Handgun License [Sheriff]

South Central Major Crimes Unit

2024-05.21.y A Resolution Authorizing the Approval to Extend the Repayment Date of an Advance of Funds, Fund #7830, Sub Fund #8312 DLEF Grant [Sheriff - Major Crimes Unit]

Fairfield County Utilities Department

2024-05.21.z A Resolution to Approve the Contract Award for the Little Walnut Generator and Transfer Switch Project; Utilities Fund #5044, Sewer [Utilities]

Payment of Bills

2024-05.21.aa A Resolution Authorizing the Approval of Payment of Invoices for Departments that Need Board of Commissioners Approval [Commissioners]

Adjourn

Public Meeting to Consider the Designation of Area for Industrial Solar, 10:30 a.m.

Land Bank Board Meeting, Liberty Center, 11:00 a.m.

Transportation Improvement District Meeting, Fairfield County Engineer's Office, 1:00 p.m.

Stormwater Utility Update, Fairfield County Engineer's Office, 2:00 p.m.

Regular Meeting #20 - 2024
Fairfield County Commissioners' Office
May 14, 2024

Review Meeting

The Commissioners met at 1:00 p.m. in the Liberty Center located at 951 Liberty Dr., Lancaster, OH. Commissioner Levacy called the meeting to order, and the following Commissioners were present: Jeff Fix and Dave Levacy. County employees present: County Administrator, Aundrea Cordle; Deputy County Administrator, Jeff Porter; Clerk to the Commissioners, Rochelle Menningen; Communications & Information Coordinator, Bennett Niceswanger; Budget Director, Bart Hampson; IT Director, Dan Neeley; Facilities & EMA Director, Jon Kochis; Utilities Director, Tony Vogel; Auditor, Dr. Carri Brown; and Assistant Prosecuting Attorneys, Amy Brown-Thompson, Steven Darnell; and Deputy Romine. Also present: Francis Martin, Jeff Williamsen, George Bennett, Betty Bennett, Mary Cullison, Ray Stemen, Chris Snider, and Bryan Everitt.

Welcome

Commissioner Levacy opened the meeting by welcoming everyone in attendance.

Public Comments

Ray Stemen of Lancaster spoke about honoring parents.

Jeff Williamsen of Greenfield Township provided a letter regarding the Eastern Cottontail Solar Project. He spoke about the urgency he felt regarding industrial solar exclusionary zones in Fairfield County.

Legal Update

Amy Brown-Thompson spoke about the allegation made regarding the Prosecutor's Office during the May 7, 2024, Commissioners' meeting. Ms. Brown-Thompson clarified that there had not been any communications provided to any townships in the county regarding industrial solar projects and asked that individuals not make false statements concerning the Prosecutor's Office.

County Administration Update

- *The County Administration Update was provided by County Administrator, Aundrea Cordle, unless otherwise noted.*

Week in Review

Chamber of Commerce Fairfield Leadership Program

The Chamber's 2024 Fairfield Leadership Program had several graduates from the County. From JFS, Marea Wesney, from the Auditor's Office, Kayla Speakman, from the Health Department, Rachel Moresea, Jamie Ehorn, Sheila Wolfe, and Gale Neville, and from Economic and Workforce Development, Bayley Fields, and Anthony Iachini.

NACo Leadership Development Academy

Fairfield County had 15 graduates of the National Association of Counties' Leadership Development Academy: Amberly Hannum in HR, Ashton Buckley from CPS, Park Technician Alex Smith, Gina Knight, Molly Thomas, and Miki Erickson with JFS, Jalen Wilson and Lorelie Banks with Juvenile Court, DD Resource Specialist, Kristin Thorne,

Regular Meeting #20 - 2024
Fairfield County Commissioners' Office
May 14, 2024

Miranda Cain, an Education Specialist with the Park District, Megan Poling with Major Crimes, IT System Specialist with DD, Robert Lovell, Project Fort Director, Scott Duff, Deputy Director of the Park District, Tommy Springer, and Diversion Case Manager with Juvenile Court, Wendy Hale.

Lancaster Fairfield Chamber of Commerce Annual Award Dinner and Trade Show

At our May 7th Meeting, we celebrated Tiffany Hedrick from the Fairfield County Sheriff's Office for being awarded the Brett Markwood First Responder Award. At the banquet, it was announced that Fairfield County Auditor, Dr. Carri Brown, won the 2024 Floyd Wolfe Community Service Award. Congratulations to both of our county employees for these prestigious recognitions.

Fairfield County Announces Application for USDA Grant Supporting Regional Food Systems

Fairfield County is pleased to announce its application submission for the Regional Food System Partnerships Program, a USDA grant through the Local Agriculture Market Program (LAMP). The proposed needs assessment earmarks \$100,000 to identify existing gaps within local food production, including meat and poultry, while addressing issues related to processing, storage, transportation, and fresh food delivery. The grant's coverage encompasses 'Scioto to the Muskingum,' with adjacent counties actively participating in steering committees to contribute their expertise in devising planning strategies and solutions. Aligned with the Fairfield Growing initiative, established in 2011 and updated in 2022, Fairfield County invests in available funding opportunities that benefit local farms, families, businesses, and institutions.

Facing ongoing growth and expansion pressures from the Columbus metropolitan region due to continued development throughout the area, Fairfield County is reinforcing its commitment to agriculture and farming as a core aspect of the region's identity. The grant will benefit a network of food producers and distributors spanning Fairfield County and neighboring communities.

Thank you to Commissioner Fix for suggesting that the County explore this opportunity and Hicks Partners for their assistance with writing and submitting this grant. A special thank you to Holly Mattei for her leadership on the grant committee and to Jonathan Ferbrache for his outreach to the surrounding areas to secure their support of the grant.

Highlights of Resolutions

Administrative Approvals

The review packet contains a list of administrative approvals.

Resolution Review

There are 9 resolutions on the agenda for the voting meeting.

Resolutions of note:

- The Engineer's Office has 3 resolutions on the voting agenda, two to approve advertising for pavement markings and for micro surfacing, and one for the bridge load rating.

Regular Meeting #20 - 2024
Fairfield County Commissioners' Office
May 14, 2024

- RPC has a resolution for the final plat approval for the second phase of the second section of Meadowmoore Reserve in Violet Township. You also have a mylar to sign for that approval.

Calendar Review/Invitations Received

- *The review of calendar items, invitations received, and correspondence received was provided by the Clerk to the Board of Commissioners, Rochelle Menningen.*
 - Family and Children First Full Council Meeting, May 16, 2024, 8:30 a.m., Fairfield County Agricultural Center, 831 College Ave., Lancaster
 - Lancaster Fairfield Community Action Agency Board of Directors Meeting, May 16, 2024, 11:30 a.m., Recycling Center, 1761 E. Main St., Lancaster
 - Workforce Center Graduation, May 17, 2024, 11:30 a.m., Fairfield County Workforce Center, 4465 Coonpath Rd., Carroll
 - TID Board Meeting, May 21, 2024, 1:00 p.m., Fairfield County Engineer's Office, 3026 W. Fair Ave., Lancaster
 - Fairfield County Sheriff's Office 2023 Annual Recognition Ceremony, May 23, 2024, 12:00 p.m., the Eagles, Forest Rose Aerie, 1936 E. Main St., Lancaster

Correspondence Received

- Press Release, Regional Planning Commission, May 8, 2024, "Fairfield County Announces Application for USDA Grant Supporting Regional Food Systems"
- Press Release, Office of the County Auditor, May 8, 2024, "Ohio Department of Taxation "The Finder" Tool Provides Various Tax Information"
- Memo, Dr. Carri Brown, County Auditor, May 9, 2024, Subject: Principal Employers of the County
- Fairfield County Auditor's Wins of the Week, May 10, 2024

- Press Release, Office of the County Auditor, May 13, 2024, "Auditor Brown Receives the Floyd Wolfe Community Service Award"
- Correspondence Regarding the Village of Amanda and Ed Wolfe Park
- Correspondence Regarding Industrial Solar Projects
- Letter, Eastern Cottontail Solar Project, May 8, 2024, Re: Eastern Cottontail Solar Public Information Meeting

Old Business

Commissioner Fix spoke about attending calling hours for former Auditor Barbara Curtiss and for former Mayor of Bremen, Mike Henwood. The Commissioner spoke about his appreciation of their performance in their former roles. The Commissioner also spoke about SB 52 and grandfathered industrial solar projects. He stated his support for the agricultural community in Fairfield County and for the need for food production. He stated that the county had submitted a USDA Regional Food Systems Partnership Grant application which required a commitment of matching funds. He reiterated that the Commissioners are supportive of agriculture and the county's farmers.

Regular Meeting #20 - 2024
Fairfield County Commissioners' Office
May 14, 2024

Ms. Cordle spoke about the assistance of Hicks Partners with the USDA application process. She also spoke about promoting Hicks Partners services to the villages, townships, and cities in the county and added that it was good to experience their expertise at work.

Ms. Mattei spoke about the twenty-one letters of support that were submitted with the USDA application.

Commissioner Levacy congratulated Dr. Brown for receiving the Floyd Wolfe Award.

New Business

Commissioner Fix spoke about meeting with additional townships, villages, and the City of Lancaster regarding land use planning. He added that progress with the cities and townships has continued since the presentation of the Land Use Plan.

Mr. Szabrak spoke about Fairfield County's collaboration with townships and villages on land use planning being a model to many other entities.

Commissioner Levacy spoke about the 2024 Workforce Center graduates and the contribution those graduates will make to the future workforce.

Mr. Szabrak stated there should be eighty-four 2024 graduates from the Workforce Center.

Dr. Brown spoke about Barbara Curtiss and working under her leadership and added that Ms. Curtiss started the GIS program in the county. Dr. Brown also spoke about the passing of former County Treasurer, David Jones, who served on two occasions as County Treasurer. She added that there would be an upcoming weights and measures presentation; and spoke about top employer awards and diversity in our economic development base. She also added her appreciation of public service in the county and of her real estate team. Dr. Brown stated that her office will have an evening call center on June 22nd regarding tax bills.

Regular (Voting) Meeting

The Commissioners met at 1:00 p.m. in the Liberty Center located at 951 Liberty Dr., Lancaster, OH. Commissioner Levacy called the meeting to order, and the following Commissioners were present: Jeff Fix and Dave Levacy. County employees present: County Administrator, Aundrea Cordle; Deputy County Administrator, Jeff Porter; Clerk to the Commissioners, Rochelle Menningen; Communications & Information Coordinator, Bennett Niceswanger; Budget Director, Bart Hampson; IT Director, Dan Neeley; Facilities & EMA Director, Jon Kochis; Utilities Director, Tony Vogel; Auditor, Dr. Carri Brown; and Assistant Prosecuting Attorneys, Amy Brown-Thompson, Steven Darnell; and Deputy Romine. Also present: Francis Martin, Jeff Williamsen, George Bennett, Betty Bennett, Mary Cullison, Ray Stemen, Chris Snider, and Bryan Everitt.

Pledge of Allegiance

Commissioner Levacy asked everyone to rise as able and led the Pledge of Allegiance.

Announcements

Clerk Menningen announced that the May 21st meeting would also be held at the Liberty Center, but would begin at 9:00 a.m.

**Regular Meeting #20 - 2024
Fairfield County Commissioners' Office
May 14, 2024**

Approval of Minutes for May 7, 2024

On the motion of Jeff Fix and the second of Dave Levacy, the Board of Commissioners voted to approve the Minutes for the Tuesday, May 7, 2024, meeting.

Roll call vote of the motion resulted as follows:

Voting aye thereon: Jeff Fix and Dave Levacy

Approval of a Resolution from the Fairfield County Emergency Management Agency

On the motion of Jeff Fix and the second of Dave Levacy, the Board of Commissioners voted to approve the following resolution from the Fairfield County Emergency Management Agency:

2024-05.14.a A Resolution to Request Appropriations for Receipts for EMA Emergency Management Performance Grant Program 2707, 8300

Roll call vote of the motion resulted as follows:

Voting aye thereon: Jeff Fix and Dave Levacy

Approval of Resolutions from the Fairfield County Engineer

On the motion of Jeff Fix and the second of Dave Levacy, the Board of Commissioners voted to approve the following resolutions from the Fairfield County Engineer:

2024-05.14.b A Resolution to Approve Advertising for the 2024 Micro Surfacing Project

2024-05.14.c A Resolution to Approve Advertising for the 2024 Pavement Markings Project

2024-05.14.d A Resolution to Change a Bridge Load Rating (PLE-04)

Roll call vote of the motion resulted as follows:

Voting aye thereon: Jeff Fix and Dave Levacy

Approval of a Resolution from Fairfield County Job and Family Services

On the motion of Jeff Fix and the second of Dave Levacy, the Board of Commissioners voted to approve the following resolution from Fairfield County Job and Family Services:

2024-05.14.e A Resolution to Approve a Reimbursement for Share of Costs for Postage as a Memo Expenditure for Fund #2018

Roll call vote of the motion resulted as follows:

Voting aye thereon: Jeff Fix and Dave Levacy

Approval of a Resolution from the Fairfield County Regional Planning Commission

On the motion of Jeff Fix and the second of Dave Levacy, the Board of Commissioners voted to approve the following resolution from the Fairfield County Regional Planning Commission:

Regular Meeting #20 - 2024
Fairfield County Commissioners' Office
May 14, 2024

2024-05.14.f A Resolution to Approve the Meadowmoore Reserve, Section 2 – Phase 2,
Final Plat

Roll call vote of the motion resulted as follows:

Voting aye thereon: Jeff Fix and Dave Levacy

Approval of a Resolution from the Fairfield County Sheriff

On the motion of Jeff Fix and the second of Dave Levacy, the Board of Commissioners voted to approve the following resolution from the Fairfield County Sheriff:

2024-05.14.g A Resolution to Approve to Rescind Resolutions 2024-04.23.y and 2024-
05.07.v, Disposal of Vehicles by Internet Auction with GovDeals, Inc.

Roll call vote of the motion resulted as follows:

Voting aye thereon: Jeff Fix and Dave Levacy

Approval of a Resolution from Fairfield County Soil and Water Conservation District

On the motion of Jeff Fix and the second of Dave Levacy, the Board of Commissioners voted to approve the following resolution from Fairfield County Soil and Water Conservation District:

2024-05.14.h A Resolution Approving and Account-to-Account Transfer into a Major
Expenditure Object Category for Soil & Water, Fund #7026

Roll call vote of the motion resulted as follows:

Voting aye thereon: Jeff Fix and Dave Levacy

Approval of the Payment of Bills

On the motion of Jeff Fix and the second of Dave Levacy, the Board of Commissioners voted to approve the following resolution for the Payment of Bills:

2024-05.14.i A Resolution Authorizing the Approval of Payment of Invoices for
Departments that Need Board of Commissioners' Approval

Roll call vote of the motion resulted as follows:

Voting aye thereon: Jeff Fix and Dave Levacy

Adjournment

With no further business, on the motion of Jeff Fix and the second of Dave Levacy, the Board of Commissioners voted to adjourn at 1:33 p.m.

Roll call vote of the motion resulted as follows:

Voting aye thereon: Jeff Fix and Dave Levacy

The next Regular Meeting is scheduled for 9:00 a.m. on Tuesday, May 21, 2024, at the Liberty Center.

**Regular Meeting #20 - 2024
Fairfield County Commissioners' Office
May 14, 2024**

Motion by: Jeff Fix Seconded by:
that the May 14, 2024, minutes were approved by the following vote:

YEAS: Jeff Fix, Dave Levacy
ABSTENTIONS:

NAYS: None

*Approved on May 21, 2024

Dave Levacy
Commissioner

Jeff Fix
Commissioner

Steve Davis
Commissioner

Rochelle Menningen, Clerk

Leadership Conference, Meeting #19 - 2024
Fairfield County Commissioners' Office
May 14, 2024

Leadership Conference

The Leadership Conference started at 8:01 a.m. and was held at the Liberty Center, 951 Liberty Dr., Lancaster. The meeting was called to order by Commissioner Dave Levacy and Commissioners Jeff Fix and Steve Davis were also in attendance. There were an additional 122 Fairfield County employees who attended, and their names are included in the minutes packet. Four additional attendees included the three speakers, and a representative from CORSA. There was a total of 129 who attended the conference.

Welcome and Announcements

The Commissioners, the County Administrator, and the Deputy County Administrator welcomed everyone in attendance and spoke about the benefits of the yearly Leadership Conference training to the county and to county employees.

How to Manage the Disciplinary Process to Avoid Claims

Jennifer George of Fishel Downey Albrecht & Riepenhoff spoke on the importance of managing the corrective action process and how to remain consistent when disciplining employees. She also spoke on the risks of improper and nonexistent corrective action and the techniques and steps employers can use when disciplining employees. Standards of employee conduct, disciplinary investigations, and the performance evaluation process were discussed. Ms. George emphasized the importance of being prepared for situations and being organized, being objective and remaining positive, knowing how to set the mood when communicating and being polite and not threatening, knowing how to deal with difficult people, and knowing how to manage the discussion. Ms. George provided a PowerPoint, and a handout titled, "How to Manage the Corrective Action Process to Avoid Claims", that are both available in the minutes packet.

Communication in Times of Crisis

Mark Weaver, Esq., of Communications Council, Inc., spoke on crisis communication and how to respond and what to expect. He gave tips on how to communicate to the public and the stakeholders. His tips included how to prepare your crisis team, preparing the message to be delivered, and how to effectively communicate. He stressed the importance of communicating to external and internal people. Mr. Weaver provided a media communications tip card that is available in the minutes packet.

Break

During the break, Deputy County Administrator, Jeff Porter, conducted a game where contestants (conference attendees) answered questions about public sector employment.

Getting Social Media to Work with You, Not Against You

Jennifer George provided a presentation on getting social media to work for you, and not against you. She offered tips for using social media in the workplace and spoke about the First Amendment and Fourth Amendment Protections. She also spoke about employer rights under the Fourteenth Amendment. Ms. George defined First Amendment Auditors and spoke about their rights and how employers can respond. A PowerPoint and handout titled, "Getting Social Media to Work with You, Not Against You", were provided and are available in the minutes packet.

A Resolution to Establish the Ad Hoc Member to the Ohio Power Siting Board

WHEREAS, Substitute Senate Bill Number 52 (hereinafter "SB 52") as enacted by the 134th Ohio General Assembly amended 4906.01, 4906.02, and 4906.10 and enacted sections 303.57, 303.58, 303.59, 303.60, 303.61, 303.62, 4906.021, 4906.022, 4906.023, 4906.024, 4906.025, 4906.101, 4906.102, 4906.103, 4906.21, 4906.211, 4906.212, 4906.22, 4906.221, 4906.222, 4906.30, and 4906.31 of the Revised Code to permit a board of county commissioners to prevent power siting board certification of certain wind and solar facilities, to provide for ad hoc members of the power siting board, and to establish decommissioning requirements for certain wind and solar facilities; and

WHEREAS, pursuant to R.C. 4906.021(B), whenever an application is made to the Ohio Power Siting Board ("OPSB") for a certificate or a material amendment to an existing certificate for a utility facility, the OPSB shall include two voting ad hoc members to represent the interests of the residents of the county and township in which the utility facility is to be located; and

WHEREAS, pursuant to R.C. 4906.021(C)(1)(b), the Board of County Commissioners' ad hoc member shall be the president of the board of county commissioners or the president's designee.

NOW THEREFORE, BE IT RESOLVED BY THE BOARD OF COUNTY COMMISSIONERS, COUNTY OF FAIRFIELD, STATE OF OHIO:

Section 1. Board President David Levacy hereby designates Commissioner Steven A. Davis to be the Board's ad hoc member for the Ohio Power Siting Board.

Section 2. The Board of County Commissioners concurs with the designation of Commissioner Steven A. Davis as the ad hoc member for the Ohio Power Siting Board.



Ad Hoc Board Member Guidelines

The Ohio Power Siting Board (OPSB) appreciates your service and looks forward to your participation in the review process. As you select your organization's ad hoc board member, we ask that you keep the following guidelines in mind.

Do

- **Attend the local public hearing** to hear the views of local residents. If you choose to attend, you are welcome to sit at the head table with the administrative law judge (ALJ) and court reporter, or you may sit in the audience if you prefer. At the beginning of the hearing, the ALJ will introduce you, and you'll have the opportunity to welcome the public to the hearing if you wish.
- **Consult your county prosecutor or legal counsel before voting** to intervene, voting on a resolution for or against the project, or abstaining from a vote on the project.
- **Consider passing a resolution for or against the project or remain neutral.** To include your views in the staff report, we encourage the trustees and commissioners to file the resolution before the report is released.
- **Go to the Senate Bill 52 resource page** on the OPSB website, accessible from the front page of www.opsb.ohio.gov. The page includes information on S.B. 52, the OPSB siting process, and ways local officials can participate.
- **Review the case documents.** To learn more about the proposed facility, go to the OPSB website, www.opsb.ohio.gov, and search for the solar case by name, county, or case number. Once in the case record, you'll find all the documents, including public comments.
- **Attend the public hearing and evidentiary hearing for a different project** to watch the process so you know what to expect. Public hearings are always held in the community where the project is located, and evidentiary hearings are held in our office in Columbus. We can provide a list of upcoming hearings.
- **Watch a Board meeting.** The Ohio Power Siting Board meets once a month, typically on the third Thursday at 1:30 p.m. The meetings are televised, and recordings are available on our website, www.opsb.ohio.gov.
- **Review the Board meeting agenda.** Several weeks before the Board meeting, you will receive an email with a draft agenda and links to the cases the Board will review at that meeting. You may receive more than one draft before the final agenda is released.

- **Review the application, the staff report, and comments** from local residents. In addition, depending on your interest and available time, you are able and encouraged to review the documents in the case file and the applicant's website.
- **Ask questions.** By serving as the ad hoc board member, your constituents may come to you with questions and concerns. Please do not hesitate to contact Julie Graham-Price, OPSB community liaison, at 614-981-2380 or juliana.graham-price@puco.ohio.gov if you have questions about the proposed solar facility, Senate Bill 52, ad hoc responsibilities, or any other issue.

Don't

- **Vote to intervene.** Under SB 52, the township trustee and county commissioner who serve as an ad hoc member are prohibited from voting on the resolution to intervene if the trustees or commissioners seek to adopt a resolution. Intervention grants the trustees and commissioners the right to participate in the evidentiary hearing, file for rehearing, or appeal to the Ohio Supreme Court.
- **Testify at the public hearing.** As a voting member of the board, we suggest you avoid saying anything that appears that you have already decided on the application before the end of the process.
- **Serve as an ad hoc OPSB member if you:**
 - Are a party to a lease agreement with, or have granted an easement to, the developer of a utility facility.
 - Hold any other beneficial interest in a utility facility.
 - Have an immediate family member who is a party to a lease agreement with, or has granted an easement to, the developer of the utility facility.
 - Have an immediate family member who holds any beneficial interest in a utility facility; or
 - Have an immediate family member who has intervened in the OPSB proceeding for which the ad hoc member is included.

If you have a conflict of interest, as just described, you cannot serve as an ad hoc member of the OPSB, and a new ad hoc member must be appointed.

- **Disclose or use information acquired during your service if the information is confidential.** In addition, as an ad hoc board member, you are exempt from limitations on ex parte communications. Generally, ex parte communications are those made by a party without the presence of the other parties.

This means that ad hoc board members may discuss the case without the other members of the OPSB present. However, if such communications take place, you and the individuals you communicated with must disclose to the OPSB the date of the conversation and the names of those who participated in the discussion who are parties to the case.

Signature Page

Resolution No. 2024-05.21.a

A Resolution to Establish the Ad Hoc Member to the Ohio Power Siting Board
(Fairfield County Commissioners)

This resolution has not yet been voted on.

CERTIFICATE OF CLERK

It is hereby certified that the foregoing is a true and correct transcript of a resolution acted upon by the Board of County Commissioners, Fairfield County, Ohio on the date noted above.

2024-05.21.b

A resolution approving the Co-sponsorship agreement between the Fairfield County Board of Commissioners and the Fairfield County Airport Authority Board

WHEREAS, the Federal Aviation Administration (FAA) recommended a co-sponsorship agreement between the Board of Commissioners and the Airport Board be approved for future FAA grants; and

WHEREAS, the Airport Board signed and approved on May 13, 2024; and

WHEREAS, the Prosecutor's Office reviewed the agreement.

NOW THEREFORE, BE IT RESOLVED, BY THE BOARD OF COUNTY COMMISSIONERS, FAIRFIELD COUNTY, STATE OF OHIO:

Section 1. That the Fairfield County Board of Commissioners approves the Co-sponsorship agreement with the Fairfield County Airport Authority Board.

ROUTING FORM FOR CONTRACTS

The undersigned designee of the County affirms that he/she has reviewed the attached contract to ensure that it complies with County's needs and previous negotiations. The undersigned designee further affirms that the County has complied with the competitive selection process, as prescribed by Ohio Revised Code 9.17, and the applicable sections as outlined on this form, by selecting the applicable boxes below.

- A. Goods and/or Services in excess of \$75,000.00—competitively selected via an Invitation to Bid, pursuant to R.C. 307.86-307.92
- B. Goods and/or Services in excess of \$75,000.00—competitively selected via a Request for Proposals, pursuant to R.C. 307.862
- C. Public Improvement contracts—competitively selected pursuant to R.C. 153.08-153.12
- D. Architect/Engineer design services for public improvements—selected through the Request for Qualifications process pursuant to R.C. 153.65-153.72
- E. County Road Improvement/Construction—competitively selected pursuant to R.C. 5555.61
- F. The subject matter was exempt from competitive selection for the following reason(s):
- Under \$75,000
 - State Term #: _____ (copy of State Term Contract must be attached)
 - ODOT Term #: _____ (See R.C. 5513.01)
 - Professional Services (See the list of exempted occupations/services under R.C. 307.86)
 - Emergency (Follow procedure under ORC 307.86(A))
 - Sole Source (attach documentation as to why contract is sole source)
 - Other: No monetary value in agreement (cite to authority or explain why matter is exempt from competitive bidding)
- G. Agreement not subject to Sections A-F (explain): No monetary value in agreement
- H. Compliance with Fairfield County Board of Commissioners Procurement Guidelines
- No County employee, employee's family member, or employee's business associate has an interest in this contract OR such interest has been disclosed and reviewed by the Prosecutor's Office
 - No Finding for Recovery against Vendor as required under R.C. 9.24 (search via "Certified Search" on <http://ffr.ohioauditor.gov/>)
 - Obtained 3 quotes for purchases under \$75,000 (as applicable)
 - Purchase Order is included with Agreement
 - Agreement is with the Federal Aviation Administration (FAA)

Signed this 15th day of May, 2024.

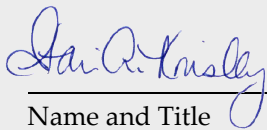

Airport Clerk

Name and Title

*** Please note that this checklist only addresses County and statutory requirements. If a contract is paid for with state and/or federal funds, please consult with the appropriate state and/or federal agency to ensure your department is complying with any additional requirements. By submitting a request for approval, you are certifying you have addressed County, statutory, and grant requirements.***

Co-sponsorship agreement between the Fairfield County Board of County Commissioners and the Fairfield County Airport Authority Board

THIS AGREEMENT made on the _____ of , _____2024 by and among the Fairfield County Board of Commissioners, and the Fairfield County Airport Authority Board.

WHEREAS, the Commissioners was created pursuant to ([Enabling Legislation]), see Exhibit "A" (Sponsor may attach applicable section from enabling legislation identifying the sponsor's authority to own/operate the airport) and is considered a "sponsor" under 49 U.S.C. § 47102(26); and

WHEREAS, the Authority was created pursuant to (see above provision for suggested language); and

WHEREAS, all of the real property comprising the Airport is owned in fee simple by the Commissioners; and

WHEREAS, the Commissioners and the Authority has the power pursuant to law to acquire, construct, equip, maintain, operate, own, and improve the Airport; and

WHEREAS, the Commissioners and the Authority desire to set forth their respective responsibilities and obligations under the FAA grants, including Airport Improvement Program (AIP) Grants and Bipartisan Infrastructure Law (BIL) Grants, for the operation of the Airport.

NOW, THEREFORE, THE COMMISSIONERS AND THE AIRPORT AUTHORITY AGREE AS FOLLOWS:

1. The parties hereto agree that they will act as Co-Sponsors of the Airport and hereby agree and acknowledge that they are obligated to comply with all rules and regulations of the FAA, including grant assurances and any other rules promulgated by the FAA.
2. The parties agree that they will not take or permit any action which would affect or restrict any of the rights and powers necessary to perform any and all other terms, conditions and assurances in any FAA grant agreement and will act promptly to acquire, extinguish, or modify any outstanding rights which would interfere with such full and complete performance by the parties.
3. The parties agree and acknowledge that, subject to the FAA Reauthorization Act of 2018, Public Law 115-254, Section 163, they will not sell, lease, encumber, or otherwise transfer title or dispose of any part of its title or other interest in the Airport without the prior written consent of the FAA.
4. The parties recognize to the extent necessary that the real estate described hereto will be subject to the terms and conditions in all grant agreements, including grant assurances, executed by the parties.
5. The parties agree that the Commissioners and the Authority will have full and complete responsibility for the day-to-day operations of the Airport and further be charged with the responsibility of ensuring that all regulations imposed by the FAA are fully met.

6. The parties agree that Grant Assurance 30, Civil Rights, extends to all of the programs and activities under the airport program and not just those receiving funding in a particular grant. Responsibility for complying with Grant Assurance 30 cannot wholly be reassigned to one sponsor or the other through a Co-Sponsorship Agreement.

7. The parties agree that the Commissioners will accept the grant agreement.

8. The parties agree that Commissioners will request, accept receipt of and disburse grant payments.

9. The parties agree that on or before December 31 of each year, the Airport Authority will provide full and accurate historical financial information for its operations for the twelve-month period preceding September, 30th.

10. The parties agree that Airport Authority will provide reports in compliance with the requirements of 2 CFR Part 200 and the grant agreement, including submission of (a) a signed/dated SF-270 (Request for Advance or Reimbursement for non-construction projects) or SF-271 (Outlay Report and Request for Reimbursement for Construction Programs); (b) an SF-425 (Federal Financial Report); and (c) for non-construction projects, FAA Form 5100-140 (Performance Report) or for construction projects FAA Form 5370-1 (Construction Progress and Inspection Report).

11. The parties agree for the benefit of the FAA's acceptance of the parties as Co-Sponsors that the duties and responsibilities as Co-Sponsors of the Airport include the transfer of the Airport assets from the County Commissioners and for the Airport Authority to assume the management and operation of the Airport if the Airport Authority is dissolved or the Airport Authority does not or is unable to execute its duties and responsibilities as owner of the Airport assets or Co-Sponsor of the Airport as determined by the County Commissioners. The parties further agree to contact the appropriate FAA Regional Airport Division or FAA Airport District Office for technical assistance at least 180 days in advance or as early in the process as practicable prior to terminating this Agreement.

12. The parties acknowledge that all revenues generated by the Airport property will be expended by each party for the capital or operating costs of the Airport.

13. The parties further agree that from time to time the parties will provide regular reports, and other reports as necessary, to the respective bodies about the operation of the Airport.

14. At all times the parties hereto agree to comply with all conditions of the grant assurances and take whatever action is necessary to ensure full and complete compliance with said grant assurances and any other regulations of the FAA that are applicable or pertinent to the requirements imposed as a condition of the receipt of the grant.

15. This Agreement extends to any and all other grants from the FAA currently existing or awarded in the future unless the parties terminate the agreement and notify the FAA of the termination in writing.

16. Except with respect to the FAA, no provision in this Agreement shall be construed to create any third-party beneficiaries hereunder.

17. Each party agrees that it shall cooperate with the other party and execute and deliver all such other instruments and take all such other actions as may be reasonably requested by the other party from time to time, consistent with the terms of this Agreement, to effectuate the purposes and provisions of this Agreement.

18. This Agreement shall be effective upon its execution by the parties and shall remain in effect until the latter of (i) twenty (20) years from its effective date or (ii) twenty (20) years from the issuance date of the most recent AIP grant supporting the Airport.

19. This Agreement embodies the entire agreement and understanding of the parties hereto in respect to the need to benefit the Airport. This Agreement supersedes all prior agreements and understanding between the parties with respect to such subject matter.

20. This Agreement may be executed in several counterparts, each of which shall be an original and all of which shall constitute but one and the same instrument.

21. This Agreement shall not be amended or modified except by agreement in writing executed by the parties. If the agreement is amended or modified, the parties agree to inform the FAA of the changes.

22. In the event any term or provision of this Agreement for any reason is held to be invalid or unenforceable by any court of competent jurisdiction, such invalidity, illegality or unenforceability shall not affect any other term or provision hereof, and this Agreement shall be interpreted and construed as if such term or provision, to the extent the same has been held to be invalid, illegal or unenforceable, had never been contained herein.

IN WITNESS WHEREOF the parties have caused these presents to be executed by their duly authorized officers the day and year above written.

The Fairfield County Board of Commissioners

By: _____

Board President Dave Levacy

The Fairfield County Airport Authority approved on May 13, 2024.

By: _____
Board President Dr. Glenn Burns

Prosecutor's Approval Page

Resolution No.

A resolution approving the Co-sponsorship agreement between the Fairfield County Board of Commissioners and the Fairfield County Airport Authority Board

(Fairfield County Commissioners)

Approved as to form on 5/15/2024 4:17:17 PM by Amy Brown-Thompson,

A handwritten signature in blue ink that reads "Amy Brown-Thompson". The signature is written in a cursive style.

Amy Brown-Thompson
Prosecutor's Office
Fairfield County, Ohio

Signature Page

Resolution No. 2024-05.21.b

A Resolution Approving the Co-Sponsorship Agreement between the Fairfield County Board of Commissioners and the Fairfield County Airport Authority Board

(Fairfield County Commissioners)

This resolution has not yet been voted on.

CERTIFICATE OF CLERK

It is hereby certified that the foregoing is a true and correct transcript of a resolution acted upon by the Board of County Commissioners, Fairfield County, Ohio on the date noted above.

A resolution to approve a fund to fund transfer from the General Fund #1001 to the Flexible Spending Account Fund # 7680.

WHEREAS, The department of Human Resources is responsible for managing the fund and payments to United Health Care (UHC) for the flexible spending account; and

WHEREAS, the Board of Commissioners allocate funding to supplement administrative and other costs for the flex spending account; and

WHEREAS, it is necessary to transfer the cash from the general fund to the Flexible Spending Account Fund to meet obligations.

NOW THEREFORE, BE IT RESOLVED BY THE BOARD OF COUNTY COMMISSIONERS, COUNTY OF FAIRFIELD, STATE OF OHIO:

Section 1. That the transfer of funds in the amount of \$15,000 hereby authorized as follows:

From: 12100149 700009 GRF Flex Spending transfers out
To: 90768000 439100 Flexible Spending transfers in

Signature Page

Resolution No. 2024-05.21.c

A Resolution to Approve a Fund-to-Fund Transfer from the General Fund #1001 to the Flexible Spending Account Fund #7680

(Fairfield County Commissioners)

This resolution has not yet been voted on.

CERTIFICATE OF CLERK

It is hereby certified that the foregoing is a true and correct transcript of a resolution acted upon by the Board of County Commissioners, Fairfield County, Ohio on the date noted above.

A resolution approving an account to account transfer in a major object expense category for the Safety & Security Budget, General Fund# 1001.

WHEREAS, appropriations are needed for contractual services; and

WHEREAS, an account to account transfer will allow proper classification of major expenditure object category in contractual services.

NOW THEREFORE, BE IT RESOLVED BY THE BOARD OF COUNTY COMMISSIONERS, COUNTY OF FAIRFIELD, STATE OF OHIO:

Section 1. That the transfer of appropriations in the amount of \$11,000 is hereby authorized as follows:

From: 12100119 capital outlay
To: 12100119 contractual services

A resolution approving an account to account transfer in a major object expense category for the Safety & Security Budget, General Fund# 1001.

For Auditor's Office Use Only:

Section 1.

\$ 11,000

<i>FROM:</i>	<i>12100119 570000</i>	<i>capital outlay</i>
<i>TO:</i>	<i>12100119 530000</i>	<i>contract services</i>

Signature Page

Resolution No. 2024-05.21.d

A resolution approving an account to account transfer in a major object expense category for the Safety & Security Budget, General Fund# 1001.

(Fairfield County Commissioners)

This resolution has not yet been voted on.

CERTIFICATE OF CLERK

It is hereby certified that the foregoing is a true and correct transcript of a resolution acted upon by the Board of County Commissioners, Fairfield County, Ohio on the date noted above.

**A Resolution authorizing a fund to fund transfer.
Auditor – fund 1080.**

WHEREAS, after unclaimed monies are held within the Trust 1080 for 5 Years, the remaining unclaimed monies should be transferred to the General Fund; and

WHEREAS, Unclaimed money for the year 2018 totaling \$27,775.37 has Been held in Trust for the required amount of time and should now be Transferred to the General fund, (Claimants may still appeal to the Commissioners in the future),

NOW THEREFORE, BE IT RESOLVED, BY THE BOARD OF COUNTY COMMISSIONERS, FAIRFIELD COUNTY, STATE OF OHIO:

Section 1. That the Fairfield County Board of County Commissioners Transfer funds in the amount of \$27,775.37 as follows:

From: 24108000 700000 Transfers Out
To: 00100110 439100 Transfers In

Prepared by: Lori Hampshire

3/22/2018	AL-ASSAAD, NIHAD & RANDA	1/29/2016	79483	\$19.05	
3/22/2018	AL-ASSAAD, NIHAD & RANDA	4/8/2016	80136	\$23.81	
3/22/2018	AL-ASSAAD, NIHAD & RANDA	5/23/2016	80509	\$19.05	
3/22/2018	AL-ASSAAD, NIHAD & RANDA	9/27/2016	81882	\$47.62	
3/22/2018	AL-ASSAAD, NIHAD & RANDA	10/28/2016	82189	\$23.81	
3/22/2018	ANDREW BENNETT & DONALD SCHEIDEGGER	8/9/2016	81354	\$90.47	
3/22/2018	BAKER, MATT	8/9/2016	81383	\$19.04	
3/22/2018	BATH & BODY WORKS	12/28/2016	82609	\$100.00	
3/22/2018	BELKEY, AUBREY	9/27/2016	81827	\$3.81	
3/22/2018	BRUSEHAM, KATIE	10/28/2016	82180	\$12.28	
3/22/2018	BURKETT & SANDERSON INC	1/8/2016	79217	\$96.00	Affidavied reques
3/22/2018	BURNETTE, GLENN	9/27/2016	81858	\$3.66	
3/22/2018	BUSH, BRANDON ANTHONY	1/21/2016	79320	\$26.00	
3/22/2018	CALEY, JEFFREY	9/27/2016	81865	\$3.81	
3/22/2018	CALVARY UNITED METHODIST CHURCH	8/9/2016	81358	\$76.19	CLAIMED
3/22/2018	CALVARY UNITED METHODIST CHURCH	9/27/2016	81835	\$83.33	CLAIMED
3/22/2018	CAMILLUS, JOHN C	1/8/2016	79227	\$28.00	
3/22/2018	CARPENTER, NAOMI	9/27/2016	81880	\$4.17	
3/22/2018	CHAPIN, JOSHUA NOEL	7/15/2016	81009	\$73.50	
3/22/2018	COLONIAL HEIGHTS FURNITURE	12/28/2016	82611	\$15.87	
3/22/2018	COOK, CINDY K	10/7/2016	82020	\$0.18	
3/22/2018	COPART	6/21/2016	1617	\$16.00	
3/22/2018	CORNWELL, AMANDA G	9/22/2016	81777	\$21.50	
3/22/2018	CORRECT CUSTOM DRYWALL INC	8/4/2016	81318	\$97.00	
3/22/2018	DEAN, SUSAN	2/12/2016	79589	\$1.64	
3/22/2018	DEB SHOP #268	10/28/2016	82169	\$19.05	
3/22/2018	DEMCO, SHANNON M	7/15/2016	81024	\$68.00	
3/22/2018	DOUCET & ASSOCIATES LLC	1/8/2016	79220	\$100.00	
3/22/2018	DRUMMOND FINANCIAL SERVICES	5/16/2016	1606	\$15.00	
3/22/2018	DRUMMOND FINANCIAL SERVICES	6/23/2016	1621	\$15.00	
3/22/2018	DRUMMOND FINANCIAL SERVICES	12/12/2016	1751	\$15.00	
3/22/2018	EAGLE LOAN COMPANY OF OHIO	7/27/2016	25911	\$30.00	
3/22/2018	EAGLE LOAN COMPANY OF OHIO	9/1/2016	26071	\$15.00	
3/22/2018	EDGINGTON, WILLIAM FRANKLIN	2/24/2016	79659	\$94.00	
3/22/2018	ELIAS, FRANK BOURNS	3/23/2016	79912	\$25.00	
3/22/2018	GOTTFRIED, GARY J	1/8/2016	79223	\$70.00	
3/22/2018	GRAHAM, JERINE LANETTE	5/11/2016	80413	\$1.00	
3/22/2018	HEMPLEMAN, SALLY	7/19/2016	81051	\$73.50	
3/22/2018	HOUSEHOLD RETAIL SERVICES	10/31/2016	82232	\$65.36	
3/22/2018	HOUSEHOLD RETAIL SERVICES	12/21/2016	82569	\$65.36	
3/22/2018	HOWARD, BRIAN R	1/21/2016	79321	\$4.75	
3/22/2018	HOWELL, SHANE	11/16/2016	82354	\$16.47	
3/22/2018	HUTCHINS, PRESTON L	1/29/2016	79501	\$122.50	
3/22/2018	IRON, VALERIE	9/27/2016	81916	\$3.81	
3/22/2018	JONES, JERRY D	8/16/2016	81474	\$5.75	
3/22/2018	JONES, KRISTEN	9/27/2016	81871	\$680.01	
3/22/2018	KEVIN F KURGIS CO LPA	1/8/2016	79228	\$304.00	
3/22/2018	LINDSAY HONDA	10/17/2016	26269	\$30.00	
3/22/2018	MACKENZIE LINNEA	8/30/2016	26056	\$19.00	
3/22/2018	MCCORMACK, LISA	2/26/2016	79696	\$10.48	
3/22/2018	MCCORMACK, LISA	10/31/2016	82235	\$7.62	
3/22/2018	MEADE, ANTHONY WAYNE	8/15/2016	81422	\$2.00	
3/22/2018	MEANS, BICHIMER, BURKHOLDER	1/7/2016	79211	\$65.00	
3/22/2018	MERICA, JOHNATHON RYAN	9/20/2016	81758	\$10.00	
3/22/2018	MILLER, LOUIS	9/27/2016	81875	\$3.66	
3/22/2018	MYERS, TRACY D	6/22/2016	80768	\$1.00	
3/22/2018	PALMER, STANTON J	11/8/2016	1724	\$16.00	
3/22/2018	PATTON CUSTOM HOMES LLC	11/17/2016	82370	\$4.60	
3/22/2018	PAYNE, NINO L	8/16/2016	81483	\$50.00	
3/22/2018	POSPISHIL, JAMES	9/27/2016	81862	\$3.66	
3/22/2018	RICE, JOSEPH LUCAS	1/22/2016	79352	\$95.50	
3/22/2018	RIEDER, PERRY E JR	3/4/2016	79822	\$152.00	
3/22/2018	RIEDER, PERRY E JR	10/28/2016	82194	\$34.00	
3/22/2018	SEESHOLTZ, CAROL	1/29/2016	79448	\$95.24	
3/22/2018	SEESHOLTZ, CAROL	4/8/2016	80109	\$57.14	
3/22/2018	SPEEDWAY	10/28/2016	82197	\$47.62	
3/22/2018	SUGA, AMBROCIO R	7/26/2016	81160	\$60.25	
3/22/2018	SUGA, BERNADITH P	7/26/2016	81163	\$60.25	
3/22/2018	THE DONAHEY LAW FIRM	1/8/2016	79239	\$6.00	
3/22/2018	TOOTLE, HEIDI J	8/17/2016	81502	\$36.75	
3/22/2018	TRIM, GAYLAND MIGUEL	7/19/2016	81036	\$450.00	CLAIMED FROM THE CLERK C
3/22/2018	VALMER LAND TITLE AGENCY	12/20/2016	1757	\$5.00	
3/22/2018	WORSTALL, JUSTIN K	1/21/2016	79332	\$64.00	
				\$4,101.12	
				-\$450.00	
				\$3,651.12	paid into the Treasure 3-22-18
				-76.19	pd 1-14-19
				-83.33	pd 1-14-19

\$3,491.60

CHECK DATE	NAME	CHECK #	AMOUNT	CLAIMED BEFO
11/19/2018	ADMIN. LOGISTICAL SUP-PUB HLTH ACCREDITATION	5272348	5,347.53	AUDITOR
12/14/2018	ALLEN, DANIEL	5274513	40.24	AUDITOR
01/22/2018	AMERICAN HOMES 4 RENT LLC	5251274	1,871.00	AUDITOR
07/30/2018	ANDERSON, DOMINIQUE	5264315	2.88	AUDITOR
07/30/2018	ANDERSON, DOMINIQUE	5264316	78.67	AUDITOR
02/05/2018	ARAUCO, CARRIE M	5252210	30.00	AUDITOR
07/30/2018	AZBELL, DAVID & CHARLENE	5264398	11.03	AUDITOR
10/01/2018	BABBS, CHRISTOPHER	5268814	29.54	AUDITOR
07/16/2018	BAIR, BONITA	5263153	6.00	AUDITOR
08/02/2018	BAKER, DAN & CARRIE	5264559	18.61	AUDITOR
06/11/2018	BALLARD, DIANA B	5260612	6.00	AUDITOR
07/30/2018	BARNHART, ROBERT	5264393	12.14	AUDITOR
04/09/2018	BAUCUM, TINNA M	5256322	6.00	AUDITOR
01/08/2018	BENDER, KENNETH	5250051	6.00	AUDITOR
12/10/2018	BENNETT, KELLY	5273790	6.00	AUDITOR
12/10/2018	BENNETT, MICHAEL	5273791	6.00	AUDITOR
01/16/2018	BERK, DALE KAY	5250783	6.00	AUDITOR
11/19/2018	BILLS, AMELIA L	5272262	30.00	AUDITOR
06/11/2018	BINKLEY, JACOB B	5260614	6.00	AUDITOR
07/30/2018	BLACK, SANDRA A.	5264230	1.17	AUDITOR
07/30/2018	BLAIR, KEN	5264348	78.67	AUDITOR
01/11/2018	BLAIR, LARRY & LANETTE	5250175	74.44	AUDITOR
02/01/2018	BLAIR, LARRY & LANETTE	5251929	74.44	AUDITOR

03/01/2018	BLAIR, LARRY & LANETTE	5253733	74.44	AUDITOR	74.44	AUDITOR
03/29/2018	BLAIR, LARRY & LANETTE	5255601	74.44	AUDITOR	74.44	AUDITOR
05/03/2018	BLAIR, LARRY & LANETTE	5257880	74.44	AUDITOR	74.44	AUDITOR
05/31/2018	BLAIR, LARRY & LANETTE	5259872	74.44	AUDITOR	74.44	AUDITOR
08/02/2018	BLAIR, LARRY & LANETTE	5264537	74.44	AUDITOR	74.44	AUDITOR
01/22/2018	BLANKENSHIP, ZAYLYNN MARIE	5251334	6.00	AUDITOR	6.00	AUDITOR
03/15/2018	BOONE, MARY ANN	5254940	616.25	AUDITOR	207.50	AUDITOR
03/19/2018	BOONE, MARY ANN	5255102	207.50	AUDITOR	956.25	AUDITOR
03/22/2018	BOONE, MARY ANN	5255357	956.25	AUDITOR	312.50	AUDITOR
03/26/2018	BOONE, MARY ANN	5255503	312.50	AUDITOR	30.00	AUDITOR
05/07/2018	BOTOS, STEVEN	5258178	30.00	AUDITOR	27.40	AUDITOR
12/14/2018	BRINKLEY, DENISE	5274515	27.40	AUDITOR	30.00	AUDITOR
11/19/2018	BROCKWELL, WADE S	5272324	30.00	AUDITOR	6.00	AUDITOR
07/23/2018	BROWN, TAMMIE RENEE	5263816	6.00	AUDITOR	20.00	AUDITOR
10/25/2018	BUSHEE, MAKAYLA	5270592	20.00	AUDITOR	60.00	AUDITOR
11/19/2018	BUSHER, TIMOTHY J	5272322	60.00	AUDITOR	6.00	AUDITOR
08/27/2018	BUTLER, MARK JONATHON	5266466	6.00	AUDITOR	1.60	AUDITOR
07/30/2018	CAMPTON, LINDA	5264433	1.60	AUDITOR	95.79	AUDITOR
07/19/2018	CANNON JR, JERROLD J	5263443	95.79	AUDITOR	6.00	AUDITOR
12/14/2018	CARPENTER, PAYTON	5274528	6.00	AUDITOR	6.00	AUDITOR
03/26/2018	CHAFFIN, QUENTON T	5255519	6.00	AUDITOR	8.95	AUDITOR
07/30/2018	CHENOWITH, MICHAEL	5264388	8.95	AUDITOR	100.00	AUDITOR
07/05/2018	CLARK, JEREMIAH	5262432	100.00	AUDITOR	6.00	AUDITOR
04/16/2018	COLE, NATASHA LYNN	5256829	6.00	AUDITOR	25.62	AUDITOR
10/11/2018	COOK, DAVID OR NICHOLE	5269572	25.62	AUDITOR	55.35	AUDITOR
10/04/2018	COTTRELL, JASON & ANGELA	5269034	55.35	AUDITOR	6.00	AUDITOR
06/11/2018	COX, MICHAEL	5260618	6.00	AUDITOR	60.00	AUDITOR
05/10/2018	CROWLEY, KEVIN R	5258323	60.00	AUDITOR	187.50	AUDITOR
06/21/2018	CROSSFIT 740 LLC	5261573	187.50	AUDITOR	30.00	AUDITOR
08/23/2018	CROSSFIT 740 LLC	5266207	30.00	AUDITOR	64.39	AUDITOR
05/24/2018	CROWTHER, KEVIN & KRISTIN	5259616	64.39	AUDITOR	30.00	AUDITOR
11/19/2018	CURRY, ASHLEY D	5272264	30.00	AUDITOR	6.00	AUDITOR
12/14/2018	DAMRON, ALEXANDER	5274509	6.00	AUDITOR	6.00	AUDITOR
10/01/2018	DANNER, TYLER	5268852	6.00	AUDITOR	6.00	AUDITOR
07/23/2018	DAY-REID, JOSHUA RODNEY	5263815	6.00	AUDITOR	30.00	AUDITOR
06/11/2018	DECKER, ANGELIQUE M	5260629	30.00	AUDITOR	6.00	AUDITOR
01/29/2018	DENT, LUCINDA	5251848	6.00	AUDITOR	6.00	AUDITOR
07/23/2018	DEVAULT, AMBER JEAN	5263813	6.00	AUDITOR	30.00	AUDITOR
10/22/2018	DITTOE, SHERRI L	5270386	30.00	AUDITOR	6.00	AUDITOR
06/11/2018	DOE, JESSICA	5260616	6.00	AUDITOR	6.00	AUDITOR
02/20/2018	DRENNER, RONALD	5253321	6.00	AUDITOR	6.00	AUDITOR
03/26/2018	EDWARDS, SHARON	5255522	6.00	AUDITOR	6.00	AUDITOR
12/14/2018	EPPLEY, JESSICA	5274520	6.00	AUDITOR	100.00	AUDITOR
07/30/2018	EVANS, ROBERT & ANNA	5264228	100.00	AUDITOR	6.00	AUDITOR
10/01/2018	FARTHING, SHAUNA C	5268806	6.00	AUDITOR	100.00	AUDITOR
07/30/2018	FENN, LAURA	5264290	100.00	AUDITOR	6.00	AUDITOR
10/01/2018	FINNEFROCK, MICHELLE	5268835	6.00	AUDITOR	6.00	AUDITOR
04/30/2018	FORSYTHE, AUDREY	5257784	6.00	AUDITOR	6.00	AUDITOR
10/01/2018	FRIESNER, ANGELA	5268808	6.00	AUDITOR	30.00	AUDITOR
11/19/2018	FUNK, CAIUN B	5272266	30.00	AUDITOR	6.00	AUDITOR
05/07/2018	GAINES, KAYE ESTER	5258141	6.00	AUDITOR	6.00	AUDITOR
06/25/2018	GAINES, KAYE ESTER	5261821	6.00	AUDITOR	6.00	AUDITOR
09/04/2018	GEORGE, STEPHEN M	5266900	6.00	AUDITOR	800.00	AUDITOR
10/04/2018	GILLILAND, GEORGE K	5269144	800.00	AUDITOR	30.00	AUDITOR
01/16/2018	GLASGOW, J GREGORY	5250821	30.00	AUDITOR	117.84	AUDITOR
12/14/2018	GORDON FOOD SERVICE INC	5274449	117.84	AUDITOR	6.00	AUDITOR
06/25/2018	GROFF, CANDANCE SUE	5261819	6.00	AUDITOR	6.00	AUDITOR
10/01/2018	HAND, MICHELLE	5268836	6.00	AUDITOR	6.00	AUDITOR
10/01/2018	HARVEY, YVONNE	5268853	6.00	AUDITOR	70.32	AUDITOR
07/30/2018	HASBROOK, JULIE	5264443	70.32	AUDITOR	30.00	AUDITOR
12/14/2018	HEDGES, JAMES K	5274554	30.00	AUDITOR	30.00	AUDITOR
07/09/2018	HIXENBAUGH, KAREN	5262720	30.00	AUDITOR	30.00	AUDITOR
04/23/2018	HOOPER, DEBRA	5257351	30.00	AUDITOR	30.00	AUDITOR
07/09/2018	HORN, DENNIS J	5262705	30.00	AUDITOR	6.00	AUDITOR
04/30/2018	HORVATH, SABRINA	5257811	6.00	AUDITOR	6.00	AUDITOR
03/26/2018	HULL, AMBER L	5255511	6.00	AUDITOR	78.67	AUDITOR
07/30/2018	HUNCKLER, TIMOTHY	5264289	78.67	AUDITOR	6.00	AUDITOR
10/01/2018	HURST, AMANDA	5268807	6.00	AUDITOR	131.84	AUDITOR
09/13/2018	JOHNSON, DAVID & TERI	5267695	131.84	AUDITOR	30.00	AUDITOR
06/11/2018	JOHNSTON, BROOKE E	5260633	30.00	AUDITOR	6.00	AUDITOR
01/16/2018	JONES, WESLEY	5250786	6.00	AUDITOR	3,829.72	AUDITOR
06/18/2018	KNECHT, ROGER D	5261326	3,829.72	AUDITOR	10.00	PAYROLL
06/08/2018	KING, PASCAL A	138713	10.00	PAYROLL	141.68	PAYROLL
11/16/2018	KING, PASCAL A	139094	141.68	PAYROLL	500.00	AUDITOR
10/29/2018	KROGER	5270787	500.00	AUDITOR	110.00	AUDITOR
05/21/2018	KRUSE, CURTIS M	5259253	110.00	AUDITOR	6.00	AUDITOR
10/22/2018	KUBIAK, KALONI SHAVONNE	5270357	6.00	AUDITOR	78.67	AUDITOR
07/30/2018	LAMBERT, KIRK	5264424	78.67	AUDITOR	6.00	AUDITOR
01/22/2018	LEHMAN, CHRISTOPHER	5251327	6.00	AUDITOR	18.61	AUDITOR
05/31/2018	LEWIS, WAYNE & BETTY	5259973	18.61	AUDITOR	18.61	AUDITOR
06/28/2018	LEWIS, WAYNE & BETTY	5262013	18.61	AUDITOR	18.61	AUDITOR
08/02/2018	LEWIS, WAYNE & BETTY	5264634	18.61	AUDITOR	18.61	AUDITOR
09/06/2018	LEWIS, WAYNE & BETTY	5267046	18.61	AUDITOR	18.45	AUDITOR
10/04/2018	LEWIS, WAYNE & BETTY	5269081	18.45	AUDITOR	6.00	AUDITOR
03/26/2018	LININGER, BRAD A	5255514	6.00	AUDITOR	34.00	AUDITOR
04/05/2018	LUBE QUIK	5256162	34.00	AUDITOR	6.00	AUDITOR
09/10/2018	MAGER, KAREN	5267329	6.00	AUDITOR	6.00	AUDITOR
09/10/2018	MAGER, MATTHEW	5267330	6.00	AUDITOR	6.00	AUDITOR
04/30/2018	MANGUS, RYAN	5257810	6.00	AUDITOR	60.67	AUDITOR
07/30/2018	MASTELLER, JEFF & LINDA	5264389	60.67	AUDITOR	30.00	AUDITOR
09/17/2018	MAYER, JENNIFER L	5267960	30.00	AUDITOR	1,120.57	AUDITOR
02/12/2018	MB FINANCIAL BANK NA	5252718	1,120.57	AUDITOR	6.00	AUDITOR
09/10/2018	MCLELLAN, MICHELLE	5267331	6.00	AUDITOR	30.00	AUDITOR
04/02/2018	MCMAHAN, JENNIFER A	5255970	30.00	AUDITOR	6.00	AUDITOR
05/14/2018	MCNALLY, OFFICER JOHN	5258768	6.00	AUDITOR	6.00	AUDITOR

10/11/2018	METTLER TOLEDO INC	371.34	AUDITOR
08/13/2018	MITTS, SABRINA ANN	6.00	AUDITOR
12/03/2018	MOORER, TRAYVIN	6.00	AUDITOR
04/09/2018	MORRIS, JESSICA MICHELLE	6.00	AUDITOR
11/19/2018	MORRISON, MINDY	6.00	AUDITOR
07/30/2018	MURPHY, KEITH	117.79	AUDITOR
04/19/2018	NEUBECKER, ALEC	15.00	AUDITOR
06/21/2018	NEXTEL COMMUNICATIONS	42.80	AUDITOR
01/08/2018	NOBLE, BRADY	6.00	AUDITOR
01/08/2018	NOBLE, HOLLY ELIZABETH	6.00	AUDITOR
07/30/2018	NYE, BRENDA	1.35	AUDITOR
05/17/2018	ORICK, LINDA	783.72	AUDITOR
06/08/2018	PERFORMANT RECOVERY INC	1387.02	PAYROLL
04/30/2018	PERRY, THAD	6.00	AUDITOR
07/30/2018	PHILLIPS, CARLY	78.67	AUDITOR
05/18/2018	PIERCE, EVELYN A	1385.78	PAYROLL
07/30/2018	POPE, PEGGY	106.70	AUDITOR
06/11/2018	POSTON, JONATHAN M	30.00	AUDITOR
06/11/2018	PREVETTE, ROBERTA ROSEANN	6.00	AUDITOR
05/21/2018	PURVIS, ZANE	30.00	AUDITOR
07/30/2018	RAMOS, JESSICA & RAPHAEL	78.67	AUDITOR
11/19/2018	RANDOLPH, BRANDEN SCOTT	6.00	AUDITOR
06/07/2018	RANDOLPH, LEIGHA	395.00	AUDITOR
11/19/2018	REDMAN, AARIONNA	30.00	AUDITOR
10/01/2018	REDMOND, GARY	6.00	AUDITOR
02/05/2018	REINER, RICHARD O	30.00	AUDITOR
03/12/2018	RHYMER, JEFFREY L	30.00	AUDITOR
01/08/2018	RITCHEY, JAMES M	6.00	AUDITOR
12/14/2018	ROACH, MELISSA C	60.00	AUDITOR
07/23/2018	ROBERT K FOX FAMILY Y	100.00	AUDITOR
09/10/2018	ROBERT K FOX FAMILY Y	133.00	AUDITOR
03/19/2018	RODGERS JR, JOHN M	6.00	AUDITOR
01/22/2018	ROLLINS, LEONNA	6.00	AUDITOR
11/19/2018	SANDERS, DUSTIN J	30.00	AUDITOR
03/01/2018	SCHEER, KELLIE OR JESS	223.32	AUDITOR
05/03/2018	SCHEER, KELLIE OR JESS	223.32	AUDITOR
01/08/2018	SCHNEIDER, JOHNATHAN	6.00	AUDITOR
07/30/2018	SHEPPARD, DEBBIE	15.60	AUDITOR
12/14/2018	SIMPLEXGRINNELL	43.00	AUDITOR
06/21/2018	SKIPPER, NICHOLAS	525.00	AUDITOR
04/23/2018	SMITH, ASHLEY M	30.00	AUDITOR
02/05/2018	SMITH, JESSE D	30.00	AUDITOR
03/19/2018	SMITH, JOSEPH CHRISTOPHER	6.00	AUDITOR
01/11/2018	SMITH, MARK & ANDREA	18.61	AUDITOR
10/04/2018	SMITH, MARK & ANDREA	18.45	AUDITOR
12/06/2018	SMITH, MARK & ANDREA	18.45	AUDITOR
02/05/2018	SMITH, MICHAEL O	30.00	AUDITOR
05/21/2018	STEBELTONSIDNER ATTORNEYS	227.00	AUDITOR
06/11/2018	STRATTON, ALETHIA A	30.00	AUDITOR
08/16/2018	SUPREME COURT OF OHIO	98.00	AUDITOR
07/30/2018	SWARTZ, ALLISON	78.67	AUDITOR
07/23/2018	TAYLOR, THOMAS A & KATHERINE	4.98	AUDITOR
07/30/2018	TOOLE, CATHERIN	12.13	AUDITOR
07/30/2018	TOOLE, CATHERIN	78.67	AUDITOR
03/12/2018	TRAN, BRUCE K	30.00	AUDITOR
08/20/2018	TUCKER, MARK	6.00	AUDITOR
01/25/2018	VAJEN MD, THOMAS R	4,817.25	AUDITOR
03/15/2018	VARNELL, CHRISTINA	336.00	AUDITOR
02/05/2018	VOGT II, JIMMIE D	30.00	AUDITOR
03/12/2018	WARNCKE, BRET M	30.00	AUDITOR
04/19/2018	WEATHERSPOON, REESE	2.00	AUDITOR
06/11/2018	WEBER, SCOTT A	30.00	AUDITOR
01/08/2018	WEBER, TERRY	6.00	AUDITOR
02/12/2018	WHITE JR, WILLIAM W	6.00	AUDITOR
07/30/2018	WILKENS, JOE	4.75	AUDITOR
09/10/2018	WILLIS, SUSAN P	6.00	AUDITOR
10/11/2018	WILSON JR, ARNOLD	28.92	AUDITOR
03/19/2018	WILSON, KYRA	6.00	AUDITOR
05/03/2018	WILSON, SCOTT & FRANCE	502.46	AUDITOR
07/05/2018	WILSON-VALDEZ, MALAYSHIA	50.00	AUDITOR
07/30/2018	WITHEM, ROGER & SHARON	71.72	AUDITOR
07/30/2018	YOUNG, ROBERT	121.33	AUDITOR

29,631.30
(5,347.53)
24,283.77

24,283.77 AUDITOR'S TOTAL

3,491.60 CLERKS TOTAL
50.00 PROBATE
50.00 JUV. CRT

\$27,775.37

TOTAL TOTAL

2018 TO BE TRANSFERRED TO 1080 IN 2020 6-5-2020

2018 TO BE TRANSFERRED TO 1001 IN 2024

2018 TO BE TRANSFERRED TO 1001 IN 2024

Signature Page

Resolution No. 2024-05.21.e

A Resolution Authorizing a Fund-to-Fund Transfer, Auditor, Fund #1080

(Fairfield County Auditor- Finance)

This resolution has not yet been voted on.

CERTIFICATE OF CLERK

It is hereby certified that the foregoing is a true and correct transcript of a resolution acted upon by the Board of County Commissioners, Fairfield County, Ohio on the date noted above.

A Resolution to Amend Resolution 2022-09.27.k, Which Established the Fairfield County Route 33 Community Reinvestment Area (CRA); and the Housing Officer, Community Reinvestment Housing Council, and Tax Incentive Review Council (TIRC) for the Aforementioned CRA

WHEREAS, resolution 2022-09.27.k was created and passed by the Fairfield County Board of Commissioners; and

WHEREAS, section 8 of resolution 2022-09.27.k identifies the members of the Fairfield County Route 33 Community Reinvestment Area TIRC; and

WHEREAS, within R.C. 5709.85 (A)(1) it states the TIRC, along with other identified individuals in R.C. 5709.85 (A)(1), shall consist of “an individual appointed by the board of education of each city, local, exempted village, and joint vocational school district to which the instrument granting the exemption applies”; and

WHEREAS, according to R.C. 5709.85 (A)(1) a representative from Eastland-Fairfield Career & Technical School should be included as a member of the Fairfield County Route 33 Community Reinvestment Area TIRC.

NOW THEREFORE, BE IT RESOLVED BY THE BOARD OF COUNTY COMMISSIONERS, COUNTY OF FAIRFIELD, STATE OF OHIO:

Section 1. That the Board of Commissioners resolve to amend resolution 2022-09.27.k to include a representative from Eastland-Fairfield Career & Technical School (EFCTS), as appointed by EFCTS, as a member of the tax incentive review council.

Section 2. Resolution 2022-09.27.k will remain the governing document for all activity relating to the creation of a community reinvestment area, designation of a housing officer to administer the program, and creation of a community reinvestment housing council and tax incentive review council.

Signature Page

Resolution No. 2024-05.21.f

A Resolution to Amend Resolution 2022-09.27.k, Which Established the Fairfield County Route 33 Community Reinvestment Area (CRA); and the Housing Officer, Community Reinvestment Housing Council, and Tax Incentive Review Council (TIRC) for the Aforementioned CRA

(Fairfield County Economic & Workforce Development)

This resolution has not yet been voted on.

CERTIFICATE OF CLERK

It is hereby certified that the foregoing is a true and correct transcript of a resolution acted upon by the Board of County Commissioners, Fairfield County, Ohio on the date noted above.

A resolution authorizing the approval of repayment of an advance to the General Fund – Fund #2881 EV Charging Station Fund

WHEREAS, Fund #2881– EV Charging Station Fund; and

WHEREAS, an advance was approved on November 23, 2021, Resolution 2021-11.23.l for \$30,000; and

WHEREAS, the monies have been collected and deposited to make repayment to the General Fund Advance.

NOW THEREFORE, BE IT RESOLVED BY THE BOARD OF COUNTY COMMISSIONERS, COUNTY OF FAIRFIELD, STATE OF OHIO:

Section 1. Request that the Fairfield County Auditor repay the following advance:

DEBIT:	2881 090001 EV Charging Station	<\$30,000.00>
CREDIT:	1001 223000 General Fund Advance	\$30,000.00

Prepared by: Angel Conrad
cc: Economic & Workforce Development

Signature Page

Resolution No. 2024-05.21.g

A Resolution Authorizing the Approval of Repayment of an Advance to the General Fund, Fund #2881 EV Charging Station Fund

(Fairfield County Economic & Workforce Development)

This resolution has not yet been voted on.

CERTIFICATE OF CLERK

It is hereby certified that the foregoing is a true and correct transcript of a resolution acted upon by the Board of County Commissioners, Fairfield County, Ohio on the date noted above.

A resolution to approve an Agreement between Fairfield County and American Structurepoint, Inc.

WHEREAS, the Fairfield County Engineer is recommending that this Board of Commissioners hire American Structurepoint, Inc.; 2550 Corporation Exchange Drive; Columbus, OH 43231, to provide general engineering services as directed by the Fairfield County Engineer's Office for the stated fees and per the terms in the attached Agreement.

NOW THEREFORE, BE IT RESOLVED BY THE BOARD OF COUNTY COMMISSIONERS, COUNTY OF FAIRFIELD, STATE OF OHIO:

SECTION 1: that this Board of Commissioners resolves to approve and sign the Agreement with American Structurepoint, Inc. to provide construction inspection and testing services for the Fairfield County Engineer, for the stated fees and per the terms of the attached Agreement.

SECTION 2: that the Clerk of this Board furnish the County Engineer with a copy of this signed Agreement for further action.

Prepared by: Cheryl Downour
cc: Engineering Office

AGREEMENT

Fairfield County Commissioner's and American Structurepoint, Inc

This AGREEMENT entered into at Lancaster, Ohio on this 6th day of May 2024 by and between the County of Fairfield, State of Ohio, acting through the County Engineer, hereinafter referred to as COUNTY, and American Structurepoint, Inc, duly licensed and existing under the laws of the State of Ohio for the practice of engineering services, hereinafter, referred to as CONSULTANT, with an office located at 2550 Corporation Exchange Dr. Columbus, OH 43231.

PROJECT OVERVIEW

Project: General Engineering Services
Project Manager: Bill Maravy
Proposal Submittal Date: May 6, 2024,
Project Completion Date: September 31, 2024
Project Description: Provide General Engineering Services

SCOPE OF SERVICES

The CONSULTANT agrees to provide engineering services for the above-mentioned project, which includes the following:

Provide Plan Development, Load Ratings and Site Visits as directed by the Fairfield County Engineer's Office in accordance with the degree of care and skill ordinarily exercised by members of the same profession currently practicing under similar circumstances at the same time and in the same or similar locality.

COMPENSATION

The COUNTY agrees to compensate the consultant for the performance of the work as specified in the SCOPE OF SERVICES section of this agreement, as follows:

For actual time providing technical or engineering services and on designated projects, not to exceed a total of \$20,000.

See Attachment A for the hourly rates to be paid for services.

PROJECT PROGRESSION

The CONSULTANT shall submit weekly progress reports in the form and content acceptable to the COUNTY. They COUNTY shall be billed in consecutive 4-week increments. No payment will be processed without a weekly progress report. If the progress report reveals that the project is NOT progressing satisfactorily or if invoicing is not commensurate with the progression of work, then payment to the CONSULTANT on this agreement will be SUSPENDED. At no such time shall this be cause for the CONSULTANT to stop work on the project. In the event suspension of payment is invoked, the CONSULTANT shall then supply to the COUNTY the reason(s) for unsatisfactory performance.

Should the reason(s) for unsatisfactory progression of the work be deemed by the COUNTY to be beyond the control of the CONSULTANT or be deemed by the COUNTY to have been unforeseen at the time the project was awarded, documentation detailing a Change in Scope will be drafted in which the CONSULTANT must thoroughly explain and justify the remaining items of work needed to complete the project. In the event of a Project Ovemin, the CONSULTANT shall identify and justify all additional costs above the original estimated cost required to finish the project. Once explanations and justifications of the reasons for unsatisfactory progression of work and/or additional costs have been reviewed and accepted by the COUNTY, then an ADDENDUM shall be made to this AGREEMENT to complete the project on the time frame and fee acceptable to both the COUNTY and the CONSULTANT.

Should the reason(s) for the unsatisfactory progression of the work be deemed by the COUNTY to be in FULL control of the CONSULTANT, then the CONSULTANT is bound by this AGREEMENT to complete the work described for the sum set forth in a time frame acceptable to the COUNTY.

TERMINATION OF AGREEMENT

This Agreement may be terminated by either party upon seven (7) days' written notice should the other party fail substantially to perform in accordance with its terms through no fault of the other. In the event of termination due to the fault of others than the CONSULTANT, the CONSULTANT shall be paid his compensation for services performed to termination date including reimbursable expenses then due and all terminal expenses. On termination, all data, drawings, specifications, reports, estimates, summaries and such other information and materials as may have been accumulated by the CONSULTANT in performing this Agreement whether completed or in process must be delivered to and become property of the COUNTY.

MUTUAL WAIVER OF CONSEQUENTIAL DAMAGES AND LIMITATION OF LIABILITY

To the fullest extent permitted by law, COUNTY and CONSULTANT (1) waive against each other, and the other's employees, officers, directors, members, agents, insurers, partners, and consultants, any and all claims for or entitlement to special, incidental, indirect, or consequential damages arising out of, resulting from, or in any way related to this AGREEMENT or the project, and (2) agree that CONSULTANT's total liability to COUNTY under this AGREEMENT shall be limited to \$20,000 or the total amount of compensation received by CONSULTANT, whichever is greater, notwithstanding applicable insurance coverage.

The date of the CONSULTANT's endorsement shall serve as notice of authorization to proceed.

The undersigned, having full knowledge of the site, preliminary plans and specifications for the proposed Project and the condition of this proposal hereby agrees to furnish all services, labor, materials and equipment necessary to complete the work described in the Scope of Services by the completion date specified above and to accept the price specified above as full compensation for the work described in this request for proposal.

IN WITNESS WHEREOF, the parties hereto have made and executed this AGREEMENT on this _____ day of _____, 2024.

FAIRFIELD COUNTY COMMISSIONERS

-

-

COMPANY/CONSULT AGREEMENT

DocuSigned by:
By: Joe Schmitz
2646A9293C2C488...

Title: Project Manager

DocuSigned by:
Megan Adams
21AAC5D2FC67470...
Witness

ATTACHMENTS

The following items are to be considered a part of this contract: *Attachment "A"*

ATTACHMENT A

**AMERICAN STRUCTUREPOINT, INC.
TRANSPORTATION GROUP
2024 STANDARD HOURLY RATES SCHEDULE**

Standard Hourly Rates are subject to annual review and adjustment. Hourly rates for services in effect from Jan 1, 2024, to Dec 31, 2024, are:

<u>EMPLOYEE CLASSIFICATION</u>	<u>HOURLY RATE</u>
Principal	\$425
Project Manager	\$325
Senior Engineer	\$250
Project Engineer	\$205
*Staff Engineer	\$150
Senior Planner	\$200
Project Planner	\$185
*Staff Planner	\$105
Senior Environmental Specialist	\$290
Environmental Specialist	\$180
*Staff Scientist	\$115
Senior Designer	\$285
*Designer	\$225
*Senior Technician	\$205
*Technician	\$135
*Researcher	\$160
Senior Registered Land Surveyor	\$270
Registered Land Surveyor	\$215
Staff Land Surveyor	\$145
*Senior Survey Crew Chief	\$215
*Survey Crew Chief	\$160
*Survey Crew Member (1)	\$110
*Resident Project Representative	\$205
*Construction Inspector	\$145
*Interns and Co-ops	\$85
Landscape Architect	\$165

*Rates for these classifications are subject to overtime premium of an additional 0.18 x hourly rate.

Rates shall be escalated at the rate of 5% per year and will be applicable on Jan 1st of each year.

REIMBURSABLE EXPENSES

Reimbursable expenses include direct expenses incurred by American Structurepoint, Inc., or our consultants in the performance of work which is directly related to the project. These expenses are in addition to compensation for Basic and Supplemental services. Reimbursable expenses will be invoiced at 1.1 times our direct costs. These expenses include, but are not limited to, the following:

- Renderings, models, or colored elevations
- Governmental agency review or permit fees
- Reproduction of documents for governmental agency review, bidding, or construction
- Reimbursable expenses charged to us by subconsultants
- Airline tickets, car rental, mileage, and per diem expenses for out-of-town travel
- Couriers and overnight deliveries, including FedEx, UPS, or similar carriers

The following expenses, if incurred in the process of providing professional services included in basic services, are included in the fee noted and are not considered reimbursable expenses:

- Printing for in-house purposes and progress meetings
- Plotting expenses
- Computer charges
- Postage and handling

ORIGINAL

Carri L. Brown, PhD, MBA, CGFM

Purchase Order

Fairfield County Auditor
210 East Main Street
Lancaster, Ohio 43130

Fiscal Year 2024

Page: 1 of 1

**THIS NUMBER MUST APPEAR ON ALL INVOICES,
PACKAGES AND SHIPPING PAPERS.**

Purchase Order # **24004656 - 00**

Delivery must be made within doors of specified destination.

Expiration Date: 03/15/2025

**B
I
L
L
T
O**

COUNTY ENGINEER
3026 W FAIR AVE
LANCASTER, OH 43130
Phone: 740-652-2300

Revisions: 000

**V
E
N
D
O
R**

AMERICAN STRUCTUREPOINT INC
7260 SHADELAND STATION
INDIANAPOLIS, IN 46256

**S
H
I
P
T
O**

COUNTY ENGINEER
3026 W FAIR AVE
LANCASTER, OH 43130
Phone: 740-652-2300

VENDOR PHONE NUMBER	VENDOR FAX NUMBER	REQUISITION NUMBER	DELIVERY REFERENCE	
614-901-2235		5035		
DATE ORDERED	VENDOR NUMBER	DATE REQUIRED	FREIGHT METHOD/TERMS	DEPARTMENT/LOCATION
05/15/2024	10164			ENGINEER-ADMIN
NOTES				

PO Requisitioner Name : Julie Huggins

E mail Address : julie.huggins@fairfieldcountyohio.gov

ITEM #	DESCRIPTION / PART #	QTY	UOM	UNIT PRICE	EXTENDED PRICE
1	GENERAL ENGINEERING SERVICES - TO PROVIDE PLAN DEVELOPMENT, LOAD RATINGS AND SITE VISITS GL Account: 16202405 - 530020	1.0	EACH	\$20,000.00	\$20,000.00
GL SUMMARY					
	16202405 - 530020			\$20,000.00	

Invoice Date ___/___/___ Invoice Amount \$ _____ To Be paid ___/___/___ Warrant # _____

COUNTY AUDITOR'S CERTIFICATE

It is hereby certified that the amount \$20,000.00 required to meet the contract, agreement, obligation, payment or expenditure, for the above, has been lawfully appropriated, authorized or directed for such purpose and is in the County Treasury or in process of collection to the credit of the submitted Fund(s) free from any obligation or certification now outstanding.

Date: 05/15/2024

Carri L. Brown

Auditor Fairfield County, OH

Purchase Order Total \$20,000.00

For Department Use ONLY

ROUTING FORM FOR CONTRACTS

The undersigned designee of the County affirms that he/she has reviewed the attached contract to ensure that it complies with County's needs and previous negotiations. The undersigned designee further affirms that the County has complied with the competitive selection process, as prescribed by Ohio Revised Code 9.17, and the applicable sections as outlined on this form, by selecting the applicable boxes below.

- A. Goods and/or Services in excess of \$75,000.00—competitively selected via an Invitation to Bid, pursuant to R.C. 307.86-307.92
- B. Goods and/or Services in excess of \$75,000.00—competitively selected via a Request for Proposals, pursuant to R.C. 307.862
- C. Public Improvement contracts—competitively selected pursuant to R.C. 153.08-153.12
- D. Architect/Engineer design services for public improvements—selected through the Request for Qualifications process pursuant to R.C. 153.65-153.72
- E. County Road Improvement/Construction—competitively selected pursuant to R.C. 5555.61
- F. The subject matter was exempt from competitive selection for the following reason(s):
1. Under \$75,000
 2. State Term #: _____ (copy of State Term Contract must be attached)
 3. ODOT Term #: _____ (See R.C. 5513.01)
 4. Professional Services (See the list of exempted occupations/services under R.C. 307.86)
 5. Emergency (Follow procedure under ORC 307.86(A))
 6. Sole Source (attach documentation as to why contract is sole source)
 7. Other: _____ (cite to authority or explain why matter is exempt from competitive bidding)
- G. Agreement not subject to Sections A-F (explain): _____
- H. Compliance with Fairfield County Board of Commissioners Procurement Guidelines
1. No County employee, employee's family member, or employee's business associate has an interest in this contract OR such interest has been disclosed and reviewed by the Prosecutor's Office
 2. No Finding for Recovery against Vendor as required under R.C. 9.24 (search via "Certified Search" on <http://ffr.ohioauditor.gov/>)
 3. Obtained 3 quotes for purchases under \$75,000 (as applicable)
 4. Purchase Order is included with Agreement

American Structurepoint Agreement

Signed this _____ day of _____, 20_____.

Name and Title

*** Please note that this checklist only addresses County and statutory requirements. If a contract is paid for with state and/or federal funds, please consult with the appropriate state and/or federal agency to ensure your department is complying with any additional requirements. By submitting a request for approval, you are certifying you have addressed County, statutory, and grant requirements.***

Prosecutor's Approval Page

Resolution No.

A resolution to approve an Agreement between Fairfield County and American Structurepoint, Inc.

(Fairfield County Engineer)

Approved as to form on 5/15/2024 4:21:46 PM by Amy Brown-Thompson,

A handwritten signature in blue ink that reads "Amy Brown-Thompson". The signature is written in a cursive style.

Amy Brown-Thompson
Prosecutor's Office
Fairfield County, Ohio

Signature Page

Resolution No. 2024-05.21.h

A Resolution to Approve an Agreement between Fairfield County and American Structurepoint, Inc.

(Fairfield County Engineer)

This resolution has not yet been voted on.

CERTIFICATE OF CLERK

It is hereby certified that the foregoing is a true and correct transcript of a resolution acted upon by the Board of County Commissioners, Fairfield County, Ohio on the date noted above.

A Resolution to Approve the Construction Drawings for the Fairfield County Engineer's Salt Barn Storage Facility Project.

WHEREAS, the County Engineer is advising this Board that the construction drawings for the Fairfield County Engineer's Salt Barn Storage Facility Project have been completed, and

WHEREAS, the County Engineer is requesting that this Board of Commissioners sign the Construction Drawing cover sheet.

NOW THEREFORE, BE IT RESOLVED BY THE BOARD OF COUNTY COMMISSIONERS, COUNTY OF FAIRFIELD, STATE OF OHIO:

SECTION 1: that the Clerk of this Board return the signed Construction Drawing cover sheet, together with the signed copy of this Resolution, to the County Engineer for further action.

Prepared by: Cheryl Downour
cc: Engineering Department

Signature Page

Resolution No. 2024-05.21.i

A Resolution to Approve the Construction Drawings for the Fairfield County
Engineer's Salt Barn Storage Facility Project

(Fairfield County Engineer)

This resolution has not yet been voted on.

CERTIFICATE OF CLERK

It is hereby certified that the foregoing is a true and correct transcript of a resolution acted upon by the Board of County Commissioners, Fairfield County, Ohio on the date noted above.

A Resolution Authorizing the Approval of a Contract Award for the Replacement of Carpet Flooring – Hall of Justice Building

WHEREAS, The Board of County Commissioners owns the property at 224 East Main Street, Lancaster, which is known as the Hall of Justice, and is responsible for the maintenance of the property, and

WHEREAS, the existing carpet flooring in many of the office and Courtroom areas on all floors is outdated and in need of replacement, and

WHEREAS, the opening of sealed bids on May 10, 2024, for the Replacement of Carpet Flooring at the facility resulted in the following bids;

- Levitate Plus Flooring Systems, Inc. \$110,844.00
- Garretts Carpet Connection \$109,025.00 (Rejected)

WHEREAS, the Facilities Manager and County Administrator have reviewed the bids received with the Prosecutor and are recommending that a Contract for the Replacement of Carpet Flooring be awarded to Levitate Plus Flooring Systems, Inc, a responsive and responsible Bidder, for the amount of \$110,844.00, because the bid from Garretts Carpet was incomplete and deemed to be non-responsive, and

WHEREAS, the construction agreement has been reviewed by the County Prosecutor and approved as to form, and;

WHEREAS, funds have been placed in a capital projects fund for the specific purpose of the Replacement of the Carpet Flooring Project, and a purchase order encumbering the funds for the services has been acquired.

NOW THEREFORE, BE IT RESOLVED BY THE BOARD OF COUNTY COMMISSIONERS, COUNTY OF FAIRFIELD, STATE OF OHIO:

Section 1. The Board of County Commissioners approves the attached Contract Agreement in the amount of \$110,844.00, to Levitate Plus Flooring Systems, and authorizes its Board President to sign the documents.

Section 2. The Clerk of the Board of Commissioners will provide a signed reproduction copy to Levitate Plus Flooring Systems for their record.

NOTICE OF INTENT TO AWARD

TO: Levitate Plus Flooring Systems, Inc
13050 Watkins Road
Marysville, Ohio 43040

PROJECT: Carpet Flooring Replacement – Hall of Justice

The OWNER has considered the BID submitted by you on May 10, 2024 for the above described WORK, in response to its Advertisement for Bids, Invitation to Bidders, Addendums, and bid documents.

You are hereby notified that your BID has been accepted for all items included in the bid documents, including Addendum #1, in the amount of \$ 110,844.00.

You are required by the Information to Bidders to execute the attached Agreement and furnish the required Contractor's W-9 Tax Form, Ohio New Hire Form, Certificates of Insurance, and Workers Compensation Certificate within 10 calendar days from the date of this notice to you.

If you fail to execute said Agreement and to furnish said forms, if required, within 10 days from the date of this notice, said OWNER will be entitled to consider all your rights arising out of the OWNER's acceptance of your BID as abandoned and as a forfeiture of your BID guaranty subject to the liability as set forth in Section 153.54 of the Ohio Revised Code. The OWNER will be entitled to such other rights as may be granted by law.

You are also required to return an acknowledged copy of this NOTICE OF INTENT TO AWARD document to the OWNER.

Dated this 13th day of May, 2024.

FAIRFIELD COUNTY COMMISSIONERS

Owner

By:



Title: Deputy Director of Facilities Department

ACCEPTANCE OF NOTICE BY CONTRACTOR

Receipt of the above NOTICE OF AWARD is hereby acknowledged by Levitate Plus Flooring Systems, Inc
On this 10TH day of MAY, 2024.

Signed By:

Name and Title:

Brian Doves, PM

cc:

Fairfield County
Board of Commissioners

AGREEMENT

This Agreement is made as of the 21st day of May, 2024, between the Owner and the Contractor for the following project as listed below;

OWNER: The Fairfield County Commissioners
210 East Main Street, Room 300
Lancaster, Ohio 43130

CONTRACTOR: Levitate Plus Flooring Systems, Inc.
13050 Watkins Road
Marysville, Ohio 43040

CONTRACT NAME: Replacement of Carpet Flooring – Hall of Justice

ARCHITECT: N/A
(if applicable)

The undersigned Contractor is to furnish all material and perform all labor necessary to complete the Work described in the Contract Documents and the attached Request for Proposals (RFP) issued for the referenced project, and as noted below:

1. The parties agree that the contract shall consist of the attached Invitation to Bid (ITB) document issued on April 18, 2024, Addendum #1 issued May 6, 2024, and this agreement, all of which are collectively known as the "Contract".
2. The contract term is for ninety (90) calendar days beginning from the date of the Notice to Proceed (NTP).
3. The total amount of the contract cannot exceed One hundred ten thousand eight hundred forty four and no dollars (\$110,844.00), unless otherwise limited or expanded by a written contract amendment.
4. The Contractor and the Owner agree that the following exceptions and clarifications to the scope of work, as noted in the referenced bid documents shall apply:
 - A. Addendum #1 is included.
5. This Contract will be governed by the applicable laws of the State of Ohio, without regard to Ohio's principles of or conflicts of law. All legal actions involving all disputes arising under this Contract will be brought exclusively in a court of the State of Ohio, sitting in Fairfield County, Ohio.
6. The Contractor guarantees to pay all payroll taxes, workers' compensation insurance and any or all other taxes that may be levied against payroll by City, State or Federal agencies. The Contractor shall furnish liability and property damage insurance in the amount specified in the Bid Documents if applicable. The Contractor shall name Fairfield County Board of Commissioners as an additional insured on the liability

insurance. Such additional insured coverage shall only apply to the extent any damages covered by the policy are determined to be caused by Contractor's acts, actions, omissions or neglects and not to the extent caused by the additional insured's own acts, actions, omissions or neglects or for bare allegations. A certificate of insurance shall be provided to the Owner prior to the commencement of work. In the absence of a Bid Document, the Contractor shall furnish personal liability, property damage and theft insurance certificates in the amount of \$ 1,000,000.00 with \$ 1,000,000.00 umbrella policy, and a workers' compensation certificate, as applicable. The Contractor shall carefully screen and perform reference checks on all personnel associated with this Agreement in a satisfactory manner. In the event the Federal minimum wage law is increased, the Agreement will be increased correspondingly.

7. The Contractor agrees to protect, defend, indemnify, and hold the County; its officers, employees, and agents; and the Board of County Commissioners of Fairfield County free and harmless from and against any and all losses, penalties, damages, settlements, costs, including but not limited to attorney's fees, or liabilities of every kind and character arising out of or in connection with any acts or omissions, negligent or otherwise, of the Contractor or its employees, officers, agents, and subcontractors. The Contractor agrees to pay all damages, costs, and expenses, including but not limited to attorney's fees, of the County; its officers, employees, and agents; and the Board of County Commissioners in defending any action arising out of the aforementioned acts or omissions. Such indemnification, defense and hold harmless obligation is limited the acts and actions of the Contractor and in no way includes the acts, actions, omissions, neglects or bare allegations of a party indemnified hereunder.
8. The Contractor shall supervise and direct the Work, using the Contractor's best skill and attention, however, the County will, at all times, have access to the work. All work will be performed in a good and workmanlike manner. The Contractor shall be solely responsible for and have control over the means, methods, techniques, sequences and procedures, and for coordinating all portions of the Work. The County reserves the right to make, at any time during the progress of the work, such alterations in details of work as may be deemed necessary or desirable. Such alterations shall not invalidate this Agreement, and the Contractor agrees to perform the work as altered, the same as if it had been part of the original Agreement. In the event of an alteration the Contractor and the County shall renegotiate the contract price to reflect the costs of the work so altered.
9. The Contractor shall make adequate provisions to ensure the security and safety of the Contractor's employees, equipment and supplies and shall comply with all OSHA regulations.
10. If the Contractor defaults or neglects to carry out the Work in accordance with the Contract Documents and fails within a seven (7) day period after receipt of written notice from the Owner to commence and continue correction of such default or neglect with diligence and promptness, the Owner may, without prejudice to other remedies, correct such deficiencies. In such case, the Contract Sum shall be adjusted to deduct the cost of correction from payments due the Contractor.
11. The Contractor is responsible for all property damage caused by its employees. Said repair or replacement shall be accomplished within ten calendar days of notification. The Sheriff's Office will investigate all accidents and shall make a report.
12. The Contractor shall not permit liens or encumbrances to be filed against the County property by reason of the Contractor's failure to pay for services performed or materials furnished hereunder. The Contractor shall not assign this Agreement or any interest therein or any monies due or to become due thereunder voluntarily, involuntarily or by operation of law. Nor shall the Contractor subcontract any of its duties hereunder without the County's prior written consent.
13. In the event the County provides its written consent to a Subcontractor, the Contractor shall indemnify and save the County and the County's agents and employees harmless from all claims growing out of the lawful demands of Subcontractor's laborers, workmen, mechanics, materialmen, and furnishers of machinery and parts thereof, equipment, tools, and all supplies, incurred in the furtherance of the performance of the work. The Contractor shall, at the County's request, furnish satisfactory evidence that all obligations of the nature

designated above have been paid, discharged, or waived. If the Contractor fails to do so the County may, after having notified the Contractor, either pay unpaid bills or withhold from the Contractor's unpaid compensation a sum of money deemed reasonably sufficient to pay any and all such lawful claims until satisfactory evidence is furnished that all liabilities have been fully discharged whereupon payment to the Contractor shall be resumed, in accordance with the terms of this Agreement, but in no event shall the provisions of this sentence be construed to impose any obligations upon the County to either The Contractor, his Surety, if applicable, or any third party. In paying any unpaid bills of the Contractor, any payment so made by the County shall be considered as a payment made under the Agreement by the County to the Contractor and the County shall not be liable to the Contractor for any such payments in good faith.

14. The Contractor certifies it is an equal opportunity employer and shall remain in compliance with state and federal civil rights and non-discrimination laws and regulations including but not limited to Title VI and Title VII of the Civil Rights Act of 1964 as amended, the Rehabilitation Act of 1973, the Americans with Disabilities Act, the Age Discrimination Act of 1975, the Age Discrimination in Employment Act as amended, and the Ohio Civil Rights Law. During the performance of this Agreement, the Contractor will not discriminate against any employee, contract worker, or applicant for employment because of race, color, religion, sex, sexual orientation, national origin, ancestry, disability, Vietnam-era veteran status, age, political belief, or place of birth. Such action shall include, but is not limited to, the following: employment, upgrading, demotion or transfer; recruitment advertising, layoff, or termination; rates of pay or other forms of compensation; selection for training, including apprenticeship; and the procurement of materials and equipment. The Contractor agrees to post in conspicuous places, available to employees and applicants for employment, notices stating that the Contractor complies with all applicable federal and state non-discrimination laws. The Contractor agrees not to establish or knowingly permit any such practice or practices of discrimination or segregation in reference to anything related to this Agreement, or in reference to any contractors or subcontractors of said Contractor.
15. The Contractor certifies and affirms that the Contractor will comply with all applicable state and federal laws regarding a drug-free workplace. The Contractor will make a good faith effort to ensure that all employees performing duties or responsibilities under this Agreement, while working on the state, county, or private property, will not purchase, transfer, use or possess illegal drugs or alcohol, or abuse prescription drugs in any way.
16. The Contract Sum stated in the Agreement, including authorized adjustments, is the total amount payable by the Owner to the Contractor for performance of the Work under the Contract Documents. Additional charges MUST be approved by the Board of County Commissioners in writing and will be based on additional time spent to complete the Work. There will be no charge for extra work of an occasional, incidental, or reasonable emergency nature arising in the normal course of business conducted on the premises.
17. Upon receipt of monthly Application for Payment, the Owner will inspect the Work. When the Owner finds the Work acceptable and the County Facilities Manager has approved the invoice, payment will be processed by the Auditor's Office.
18. Nothing in this Agreement establishes a partnership, association, or joint venture with the Contractor in the conduct of the provisions of this Agreement. The Contractor shall at all times have the status of an independent without the right or authority to impose tort, contractual, or any other liability on the County or its Board of County Commissioners.
19. The Contractor warrants that at the time of entering into this Agreement, it has no interest in nor shall it acquire any interest, direct or indirect, in any contract, which will impede its ability to perform the services under this Agreement. The Contractor has no knowledge of any situation, which would be a conflict of interest. It is understood that a conflict of interest occurs when a County employee will gain financially or receive personal favors as a result of the signing or implementation of this Agreement. The Contractor shall report the discovery of any potential conflict of interest to the County. Should a conflict of interest be

discovered during the term of this contract, the County may exercise any right under this Agreement, including termination.

20. This Agreement is a matter of public record under the laws of the State of Ohio. The Contractor agrees to make copies of this Agreement promptly available to any requesting party. Upon request made pursuant to Ohio law, the County shall make available the Agreement and all public records generated as a result of this Agreement. By entering into this Agreement, the Contractor acknowledges and understands that records maintained by the Contractor pursuant to this Agreement may be deemed public records and subject to disclosure under Ohio law. The Contractor shall comply with the Ohio public records law.
21. This instrument embodies the entire agreement between the parties, and any prior understanding, agreement, or representation of any kind preceding the date of this Agreement shall not be binding upon either party except to the extent incorporated into this Agreement. There are no promises, terms, conditions, or obligations other than those contained within this Agreement. This Agreement shall supersede all previous communications, representations, or contracts, either written or oral, between the parties to this Agreement.
22. If any term or provision of this Agreement or the application of such term or provision to any person or circumstance shall, to any extent, be held invalid or unenforceable, the remainder of this Agreement or the application of such term or provision to any persons or circumstances other than those as to which it is held to be invalid or unenforceable, shall remain unaffected and each term and provision of this Agreement shall be valid and enforced to the fullest extent permitted by law.

Contractor: Levitate Plus Flooring Systems, Inc.

Signed By:

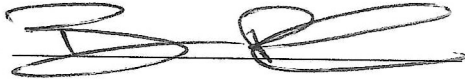

Date:

5/16/2024

ACCEPTANCE

You are hereby authorized to proceed with the above work for which the undersigned agrees to pay the amount stated in said Contract and according to the terms thereof:

Owner: Fairfield County Board of Commissioners

Signed By: _____

Date: _____

APPROVED AS TO FORM:

Assistant Prosecuting Attorney

Date: _____

ROUTING FORM FOR CONTRACTS

The undersigned designee of the County affirms that he/she has reviewed the attached contract to ensure that it complies with County's needs and previous negotiations. The undersigned designee further affirms that the County has complied with the competitive selection process, as prescribed by Ohio Revised Code 9.17, and the applicable sections as outlined on this form, by selecting the applicable boxes below.

- A. Goods and/or Services in excess of \$75,000.00—competitively selected via an Invitation to Bid, pursuant to R.C. 307.86-307.92
- B. Goods and/or Services in excess of \$75,000.00—competitively selected via a Request for Proposals, pursuant to R.C. 307.862
- C. Public Improvement contracts—competitively selected pursuant to R.C. 153.08-153.12
- D. Architect/Engineer design services for public improvements—selected through the Request for Qualifications process pursuant to R.C. 153.65-153.72
- E. County Road Improvement/Construction—competitively selected pursuant to R.C. 5555.61
- F. The subject matter was exempt from competitive selection for the following reason(s):
1. Under \$75,000
 2. State Term #: _____ (copy of State Term Contract must be attached)
 3. ODOT Term #: _____ (See R.C. 5513.01)
 4. Professional Services (See the list of exempted occupations/services under R.C. 307.86)
 5. Emergency (Follow procedure under ORC 307.86(A))
 6. Sole Source (attach documentation as to why contract is sole source)
 7. Other: _____ (cite to authority or explain why matter is exempt from competitive bidding)
- G. Agreement not subject to Sections A-F (explain): _____
- H. Compliance with Fairfield County Board of Commissioners Procurement Guidelines
1. No County employee, employee's family member, or employee's business associate has an interest in this contract OR such interest has been disclosed and reviewed by the Prosecutor's Office
 2. No Finding for Recovery against Vendor as required under R.C. 9.24 (search via "Certified Search" on <http://ffr.ohioauditor.gov/>)
 3. Obtained 3 quotes for purchases under \$75,000 (as applicable)
 4. Purchase Order is included with Agreement

Signed this _____ day of _____, 20_____.



Name and Title

*** Please note that this checklist only addresses County and statutory requirements. If a contract is paid for with state and/or federal funds, please consult with the appropriate state and/or federal agency to ensure your department is complying with any additional requirements. By submitting a request for approval, you are certifying you have addressed County, statutory, and grant requirements.***

CONTRACT FORM A

Fairfield County Commissioners
**REPLACEMENT OF CARPET FLOORING
AT THE
HALL OF JUSTICE**

BID FORM

Bids Must be submitted on this form only. (Type or Print Clearly)

Prevailing Wage rates apply.

ITEM 1 - FIRST FLOOR BASE BID WORK :

1A. WALK-OFF CARPET TILE -Type 1	\$ <u>8,268.00</u>
1B. CARPET TILE – Type 2	\$ <u>24,915.00</u>
1C. VINYL BASE	\$ <u>1,532.00</u>
Sub-Total Amount:	\$ <u>34,715.00</u>

ITEM 2 - SECOND FLOOR BASE BID WORK :

2A. CARPET TILE – Type 2	\$ <u>29,463.00</u>
2B. VINYL BASE	\$ <u>1,020.00</u>
Sub-Total Amount:	\$ <u>30,483.00</u>

ITEM 3 - THIRD FLOOR BASE BID WORK :

3A. CARPET TILE – Type 2	\$ <u>22,636.00</u>
3B. VINYL BASE	\$ <u>385.00</u>
Sub-Total Amount:	\$ <u>23,021.00</u>

ITEM 4 - FOURTH FLOOR BASE BID WORK :

4A. CARPET TILE – Type 2	\$ <u>21,985.00</u>
--------------------------	---------------------

4B. VINYL BASE

\$ 640.00

Sub-Total Amount:

\$ 22,625.00

TOTAL COMBINED BASE BID AMOUNT:

\$ 110,844.00

Acknowledgement of Addenda Received: (List all Addendum numbers and date)

Addendum # 1

Date: 5/16/2024

Addendum # N/A

Date: N/A

Addendum # N/A

Date: N/A

Having carefully read and examined the entire set of Construction Documents, including without limitation the Drawings, Specifications and all Addenda (listed above) prepared by the Owner for the above referenced Project; **and** with a clear understanding of the delineation between Base Bid and Alternate Bid work; **and** having visited and examined the site, premises, and the conditions affecting the work, the undersigned Bidder proposes to perform all Work, furnish all labor, materials and equipment for this Project in strict compliance with the Construction Documents for the sums indicated above.

Note: The breakdown of this combined bid as indicated above is requested for the purpose of assisting the Owner in evaluating the bids received. **In order for your bid to be accepted, all blanks must be filled.**

Signed By Bidder: 

Date: 5/10/2024

Printed Name: BRIAN DOVES

Title: Project Manager

Company Name: LEVINATE PLUS FLOORING SYSTEMS, INC.

Address: 13050 WATKINS ROAD

MARCSVILLE, OH 43040

Phone: 614-374-2321

CONTRACT FORM B

NON-COLLUSION AFFIDAVIT

State of Ohio)
) SS:
Fairfield County)

I MARLEN ROOSE being first duly sworn, deposes and says that
he/she is PRESIDENT (Sole Owner, a Partner, President, Secretary, etc.)
of LEVITATE PLUS FLOORING SYSTEMS, INC.

the party making the proposal; that such proposal is not made in the interest of or on behalf of any disclosed person, partnership, company, association, organization, or corporation, that such proposal is genuine and not collusive or sham; that said bidder has not directly or indirectly induced or solicited any other bidder to put in a false or sham bid, and has not directly or indirectly colluded, conspired, connived, or agreed with any bidder or anyone else to put in a sham bid, or that anyone shall refrain from bidding; that said bidder has not in any manner, directly or indirectly sought by agreement, communication or conference with anyone to fix the bid price of said bidder or of any other bidder, or to fix any overhead profit, or cost element of such bid price, or of that of any other bidder or to secure any advantage against Fairfield County; that all statements contained in such proposal are true; and further, that said bidder has not, directly or indirectly, submitted his bid price or any breakdown thereof, of the contents thereof, or divulged information or data relative thereto, or paid and will not pay any fee in connection therewith, to any corporation, partnership, company, association, public official or employee, organization, or to any other individual except to such person or persons as have a partnership or other financial interest with said bidder in this general business.

Signed: [Signature] Title: PRESIDENT

SWORN to and SUBSCRIBED before me this 16 day of May, 20 24
in Union County, State of Ohio.

My Commission expires: 08-08-2027



Mary Krafft
Notary Public, State of Ohio
My Commission Expires 08-08-27

Mary Krafft
NOTARY PUBLIC

CONTRACT DOCUMENT C

Contractor Equal Employment Opportunity Certification

During the performance of this contract, the undersigned agrees as follows:

1. The undersigned will not discriminate against any employee or applicant for employment because of race, color, religion, sex, or national origin. The undersigned will take affirmative action to ensure that applicants are employed, and that employees are treated during employment without regard to their race, color, religion or national origin. Such action shall include, but not be limited to the following: Employment, upgrading, demotion, or transfer; recruitment or recruitment advertising; layoff or termination; rates of pay or other forms of compensation; and selection for training, including apprenticeship. The undersigned agrees to post in conspicuous places, available to employees and applicants for employment, notices to be provided setting forth the provisions of this equal opportunity (federally assisted construction) clause.
2. The undersigned will, in all solicitations or advertisements for employees placed by or on behalf of the undersigned, state that all qualified applicants will receive consideration for employment without regard to race, color, religion, sex or national origin.
3. The undersigned will send to each labor union or representative of workers, with which he has a collective bargaining agreement or other contract or understanding, a notice to be provided advising the said labor union or workers' representative of the undersigned's commitment under this section, and shall post copies of the notice in conspicuous places available to employees and applicants for employment.
4. The undersigned will comply with all provisions of Executive Order No. 11246 of September 24, 1965, and of the rules, regulations, and relevant orders of the Secretary of Labor.
5. The undersigned will furnish all information and reports required by Executive Order No. 11246 of September 24, 1965, and by the rules, regulations, and relevant orders of the Secretary of Labor, or pursuant thereto, and will permit access to his books, records and accounts by the administering agency of the Secretary of labor for purposes of investigation to ascertain compliance with such rules, regulations, and orders.
6. In the event of the undersigned's non-compliance with the equal opportunity (federally assisted construction) clause of this contract of with any of the said rules, regulations, or orders, this contract may be canceled, terminated or suspended in whole or in part, and the undersigned may be declared ineligible for further Government contracts of federally assisted construction contracts in accordance with procedures authorized in Executive Order No. 11246 of September 24, 1965, and such other sanctions may be imposed and remedies invoked as provided in Executive Order No 11246 of September 24, 1965, or by rules, regulations, or order of the Secretary of Labor, or as provided by law.
7. The undersigned will include this equal opportunity (federally assisted construction) clause in every subcontract or purchase order unless exempted by the rules, regulations, or orders of the Secretary of Labor issued pursuant to section 204 of Executive Order No 11246 of September 24, 1965, so that such provision will be binding upon each subcontract or vender. The undersigned will take such action with respect to any subcontract or purchase order as the administering agency may direct as a means of enforcing such provisions, including sanctions for non-compliance: Provided, however, that in the event a contractor becomes involved in, or is threatened with, litigation with a subcontractor or vendor, as a result of such direction by the administering agency the undersigned may request the United States to enter into such litigation to protect the interest of the United States.



(Signature)

5/10/2024

(Date)

Brian Doles, Project Manager

(Name and Title of Signer, Please Print)

LEVITATE PLUS FLOORING SYSTEMS, INC.

(Firm or Company Name)

CONTRACT FORM D

**AFFIDAVIT OF CONTRACTOR OR SUPPLIER FOR
NON~DELINQUENCY OF PERSONAL PROPERTY TAXES
PER O.R.C. SECTION 5719.042**

STATE OF OHIO)
) SS
COUNTY OF FAIRFIELD)

TO: Fairfield County Commissioners

The undersigned, being first duly sworn, having submitted a bid for;

HALL OF JUSTICE FLOORING REPLACEMENT

hereby states that we were not charged at the time the bid was submitted with any delinquent personal property taxes on the general tax list of personal property of any county in which you as a taxing district have territory and that we were not charged with delinquent personal property taxes on any such tax list.

In consideration of the award of the above contract, the above statement is incorporated in said contract as a covenant of the undersigned.

[Handwritten Signature]
Contractor (Signature)

Sworn to before me and subscribed in my presence this 10 day of May, 2024.

Mary Krafft
Notary Public
Commission Expires: 08-08-2024



Mary Krafft
Notary Public, State of Ohio
My Commission Expires 08-08-27

Seal

CONTRACT FORM E

DRUG FREE WORKPLACE

This is to certify that the undersigned Contractor complies with the Drug Free Workplace Act of 1988:

1. Any individual contractor must agree not to engage in the unlawful manufacture, distribution, dispensation, possession or use of a controlled substance in the performance of this contract.
2. All organizations covered by the Drug-Free Workplace Act of 1988 are required to provide a drug-free workplace.

In the event of the Contractor's non-compliance with the drug free workplace certification, contracts may be cancelled, terminated, or suspended in whole or in part, and the Contractor may be declared ineligible for further contracts.

5/10/2024
Date

Authorized Signature of Contractor

LEVITATE FLOOR FLOORING SYSTEMS, FMC.
Company Name

BRIAN DOLES
Print Name

**BID GUARANTY AND
CONTRACT BOND**

BD

(SECTION 153.571 OHIO REVISED CODE)

KNOW ALL MEN BY THESE PRESENTS, That we, the undersigned Levitite Plus Flooring Systems, Inc. as Principal and Nationwide Mutual Insurance Company as Surety, are hereby held and firmly bound unto Fairfield County Commissioners as Obligees in the penal sum of the dollar amount of the bid submitted by the Principal to the Obligees on May 10, 2024 to undertake the Project known as: Replacement of Carpet Flooring in the Hall of Justice, 224 E Main Street, Lancaster, Ohio

The penal sum referred to herein shall be the dollar amount of the Principal's bid to the Obligees, incorporating any additive or deductive alternate proposals made by the Principal on the date referred to above to the Obligees, which are accepted by the obligee, in no case shall the penal sum exceed the amount of _____ dollars (\$ _____)

(If the above line is left blank, the penal sum will be full amount of the Principal's bid, including alternates. Alternatively, if completed, the amount stated must not be less than the full amount of the bid, including alternates, in dollars and cents. A percentage is not acceptable.) For the payment of the penal sum well and truly to be made, we hereby jointly and severally bind ourselves our heirs, executors, administrators, successors, and assigns.

THE CONDITION OF THE ABOVE OBLIGATION IS SUCH, that whereas the above named Principal has submitted a bid on the above referred project;

NOW, THEREFORE, if the Obligees accept the bid of the Principal and the Principal fails to enter into a proper contract in accordance with the bid, plans, details, specifications and bills of material; and in the Principal pays to the Obligees the difference not to exceed ten percent of the penalty hereof between the amount specified in the bid and such larger amount for which the Obligees may in good faith contract with next lowest bidder to perform the work covered by the bid; or in the event the Obligees does not award the contract to the next lowest bidder and resubmits the project for bidding the Principal will pay the Obligees the difference not to exceed ten percent of the penalty hereof between the amount specified in the bid, or the costs, in connection with the resubmission, of printing new contract documents, required advertising and printing and mailing notices to prospective bidder's whichever is less, then this obligation shall be void, otherwise to remain in full force and effect. If the Obligees accept the bid of the Principal and the Principal with ten days after the awarding of the contract, enters into a proper contract in accordance with the bid, plans, details, specifications and bills of material, which said contract is made a part of this bond the same as though set forth herein; and

IF THE SAID Principals shall well and faithfully perform each and every condition of such contract; and indemnify the Obligees against all damage suffered by failure to perform such contract according to the provisions thereof and in accordance with the plans, details, specification, and bills of material therefor; and shall pay all lawful claims of subcontractors, materialmen and laborers, for labor performed and materials furnished in the carrying forward, performing or completing of said contract; we agreeing and assenting that this undertaking shall be for the benefit of any materialmen or laborer having a just claim, as well as for the Obligees herein; then this obligation shall be void; otherwise the same shall remain in full force and effect; it being expressly understood and agreed that the liability of the Surety for any and all claims hereunder shall in no event exceed the penal amount of this obligation as herein stated.

THE SAID Surety hereby stipulates and agrees that no modification, omissions, or additions, in or to the terms of said contract or in or to the plans and specifications therefore shall in any wise affect the obligations of said Surety on this bond, and it does hereby waive notice of any such modifications, omissions or additions to the terms of the contract or to the work or to the specifications.

SIGNED AND SEALED this 8 day of May 2024

PRINCIPAL:
Levitite Plus Flooring Systems, Inc.

SURETY:
Nationwide Mutual Insurance Company

BY: [Signature]
TITLE: PRESIDENT

BY: [Signature]
Debbie Timmons Attorney-in-Fact



SEC. 9.32 REQUIRES AWARDED AUTHORITIES, SIMULTANEOUSLY WITH NOTICE OF AWARD TO CONTRACTOR, TO GIVE WRITTEN NOTICE TO SURETY AND AGENT.

SURETY COMPANY ADDRESS:
Nationwide Mutual Insurance Company
1100 Locust St.
Des Moines, IA 50391-2006

SURETY AGENTS ADDRESS:
GAD Insurance, LLC
1349 W Lane Ave, Ste 1000B
Columbus, OH 43221

KNOW ALL MEN BY THESE PRESENTS THAT:

Nationwide Mutual Insurance Company, an Ohio corporation

hereinafter referred to severally as the "Company" and collectively as "the Companies" does hereby make, constitute and appoint:
ANDREW M GARDINER; DEBBIE TIMMONS; KRISTINA A SUTTER; STUART M ALLEN;

each in their individual capacity, its true and lawful attorney-in-fact, with full power and authority to sign, seal, and execute on its behalf any and all bonds and undertakings, and other obligatory instruments of similar nature, in penalties not exceeding the sum of

FIVE HUNDRED THOUSAND AND NO/100 DOLLARS \$500,000.00

and to bind the Company thereby, as fully and to the same extent as if such instruments were signed by the duly authorized officers of the Company; and all acts of said Attorney pursuant to the authority given are hereby ratified and confirmed.

This power of attorney is made and executed pursuant to and by authority of the following resolution duly adopted by the board of directors of the Company:

"RESOLVED, that the president, or any vice president be, and each hereby is, authorized and empowered to appoint attorneys-in-fact of the Company, and to authorize them to execute and deliver on behalf of the Company any and all bonds, forms, applications, memorandums, undertakings, recognizances, transfers, contracts of indemnity, policies, contracts guaranteeing the fidelity of persons holding positions of public or private trust, and other writings obligatory in nature that the business of the Company may require; and to modify or revoke, with or without cause, any such appointment or authority; provided, however, that the authority granted hereby shall in no way limit the authority of other duly authorized agents to sign and countersign any of said documents on behalf of the Company."

"RESOLVED FURTHER, that such attorneys-in-fact shall have full power and authority to execute and deliver any and all such documents and to bind the Company subject to the terms and limitations of the power of attorney issued to them, and to affix the seal of the Company thereto; provided, however, that said seal shall not be necessary for the validity of any such documents."

This power of attorney is signed and sealed under and by the following bylaws duly adopted by the board of directors of the Company.

Execution of Instruments. Any vice president, any assistant secretary or any assistant treasurer shall have the power and authority to sign or attest all approved documents, instruments, contracts, or other papers in connection with the operation of the business of the company in addition to the chairman of the board, the chief executive officer, president, treasurer or secretary; provided, however, the signature of any of them may be printed, engraved, or stamped on any approved document, contract, instrument, or other papers of the Company.

IN WITNESS WHEREOF, the Company has caused this instrument to be sealed and duly attested by the signature of its officer the 20th day of August, 2021.

Antonio C. Albanese, Vice President of Nationwide Mutual Insurance Company

ACKNOWLEDGMENT

STATE OF NEW YORK COUNTY OF NEW YORK: ss

On this 20th day of August, 2021, before me came the above-named officer for the Company aforesaid, to me personally known to be the officer described in and who executed the preceding instrument, and he acknowledged the execution of the same, and being by me duly sworn, deposes and says, that he is the officer of the Company aforesaid, that the seal affixed hereto is the corporate seal of said Company, and the said corporate seal and his signature were duly affixed and subscribed to said instrument by the authority and direction of said Company.



Stephanie Rubino McArthur
Notary Public, State of New York
No. 02MC6270117
Qualified in New York County
Commission Expires October 19, 2024

Notary Public
My Commission Expires
October 19, 2024

CERTIFICATE

I, Laura B. Guy, Assistant Secretary of the Company, do hereby certify that the foregoing is a full, true and correct copy of the original power of attorney issued by the Company; that the resolution included therein is a true and correct transcript from the minutes of the meetings of the boards of directors and the same has not been revoked or amended in any manner; that said Antonio C. Albanese was on the date of the execution of the foregoing power of attorney the duly elected officer of the Company, and the corporate seal and his signature as officer were duly affixed and subscribed to the said instrument by the authority of said board of directors; and the foregoing power of attorney is still in full force and effect.

IN WITNESS WHEREOF, I have hereunto subscribed my name as Assistant Secretary, and affixed the corporate seal of said Company this 8 day of May, 2024.

Assistant Secretary

LEVITATE PLUS FLOORING SYSTEMS, INC.

13050 Watkins Road, Marysville, OH 43040

Brian Doles – Mobile – 614.374.2321

References

-Jeff Wargo – Marysville Exempted Village
School District – Board & Office Renovations –
937-243-0210

-Dave Huston – Hilliard City School District –
Board & Office Renovations – 614-406-9700

-Corey Mason – Memorial Hospital of Union
County – Administrative & Office Renovations
– 937-243-7190

Facilities Operations Department

Jon Kochis
Facilities Director

Dennis R. Keller
Facilities Deputy Director



Board of County Commissioners

Steven A. Davis
Commissioner

Jeff Fix
Commissioner

David L. Levacy
Commissioner

ADDENDUM #1

REPLACEMENT OF CARPET FLOORING HALL OF JUSTICE

DATE ISSUED: May 6, 2024

In accordance with the Construction Documents for the above named Project, this ADDENDUM #1, consisting of page 1 of 1 stating the revised sections of the ITB, along with revised floor plans for the Second and Fourth Floors, and the table of Carpet Replacement Areas; is hereby made a part of the Construction Documents as if written therein. RECEIPT OF THIS ADDENDUM MUST BE ACKNOWLEDGED ON THE BID FORM.

NOTIFICATION TO BIDDERS:

Item 1: Revise Section 6.2 Schedule and Coordination to add:

Paragraph 6.2.2 - All work must be performed outside of the normal weekday operating hours in the building of 7:30AM – 4:30 PM. Weekend work is permissible.

Item 2: Revise Section 4 General Conditions and Scope of Work to add:

Paragraph 4.12 - Transition strips are not required under doors to abut existing vinyl flooring. Adjust elevation of substrate with floor fill to make a smooth transition to existing flooring.

Paragraph 4.13 - Provide a minimum of 12 carpet tiles for each carpet type, as Attic Stock to the Owner at the completion of the project.

Item 3: Revised Sketches and Carpet Replacement Area Table

- A. The sketch for the Second Floor has been revised to add the Clerk of Courts area in Room 212 as s shaded area, and now included in the Work.
- B. The sketch for the Fourth Floor has been revised to delete the Clerk of Courts area in Room 405/406, as NOT SHADED and no longer included in the Work area.
- C. The table listing Carpet Replacement Areas has been revised to add the Room 212 Clerk of Courts area, and to remove the Room 405/406 Clerk of Courts area.

End of Addendum #1.

	A	B	C	D	E	F	G	H	I
1	Hall Of Justice - Carpet Replacement Areas								
3	Room Number/Name		Approximate Dimensions			Approx SF Total		Carpet Type	Base Type
4	First Floor								
5	Main Public Entry		16' x 22'2"			355.20 ft ²		1	Vinyl
6	Side Entry		7' x 35'			245 ft ²		1	Vinyl
7	Entry Connector		8' x 13'			150 ft ²		1	Vinyl
8	101 Adult Probation		33' x 66'			2178 ft ²		2	Vinyl
9	Probation Admin		15' x 24' & 11' x 5'			415 ft ²		2	Vinyl
10	102 Law Library		21.1" x 33'2"			700 ft ²		2	Vinyl
11	First Floor - 4043.20 ft ² = 449.24 yards = 450 yards								
12	Second Floor								
13	203 Com Plea Court Admin		15' x 27'			405 ft ²		2	Wood
14	203A Judge Office & RR		27' x 15' & 6' x 7'			447 ft ²		2	Wood
15	Kitchenette & Copy		6' x 16'			96 ft ²		2	Wd & Vinyl
16	205 Berens Court Room		46' x 33.2'			1527.2 ft ²		2	Wood
17	205A East Jury Room & RR's		13' x 25.6'			332.8 ft ²		2	Vinyl
18	212 Clerk of Courts & Offices		45.8 x 33			1513 ft ²		2	Vinyl
19	Second Floor - 4321 ft ² = 480 yards								
20	Third Floor								
21	306 Juv Court Admin & RR		21' x 16' & 4' x 6'			360 ft ²		2	Vinyl
22	306A Judge Office & RR		21' x 17' & 4' x 6'			387 ft ²		2	Wood
23	304 Courtroom A (South)		37' x 33'			1221 ft ²		2	Wood
24	302 Courtroom B (North)		29.6"x24.6" & 5'x9' & 6.6"x19'			738 ft ²		2	Wood
25	Third Floor - 2682 ft ² = 298 yards								
26	Fourth Floor								
27	402- Court Admin (Smith)		13'x23' / 10'x10'			399 ft ²		2	Wood
28	402A Judge Office		5.6"x5.6" / 3.6"x9.6" / 15'x19'			351 ft ²		2	Wood
29	404 Courtroom(Smith)		23'x22'			510 ft ²		2	Wood
30	401 Courtroom 1 (Miller)		22'x23' / 4'x9'			542 ft ²		2	Wood
31	403 Court Admin		11'x31' / 5'x5'			366 ft ²		2	Wd/Vinyl
32	403A Judge Office		12'x15'			180 ft ²		2	Wood
33	403B Magistrate Office		12'x11'			132 ft ²		2	Vinyl
34	407 Courtroom 2(Cleary)		15'x23' / 8'x16'			473 ft ²		2	Vinyl
35	Fourth Floor - 2953 ft ² = 328 yards								
36	Total Carpet R/R = 13,999.20 ft² = 1,556 Yards								
37	ADDENDUM #1								

BUILDING FLOOR PLAN



MAIN STREET

Fairfield County Hall of Justice

SECOND FLOOR

ADDENDUM #1



BUILDING FLOOR PLAN

NORTH 

MAIN STREET

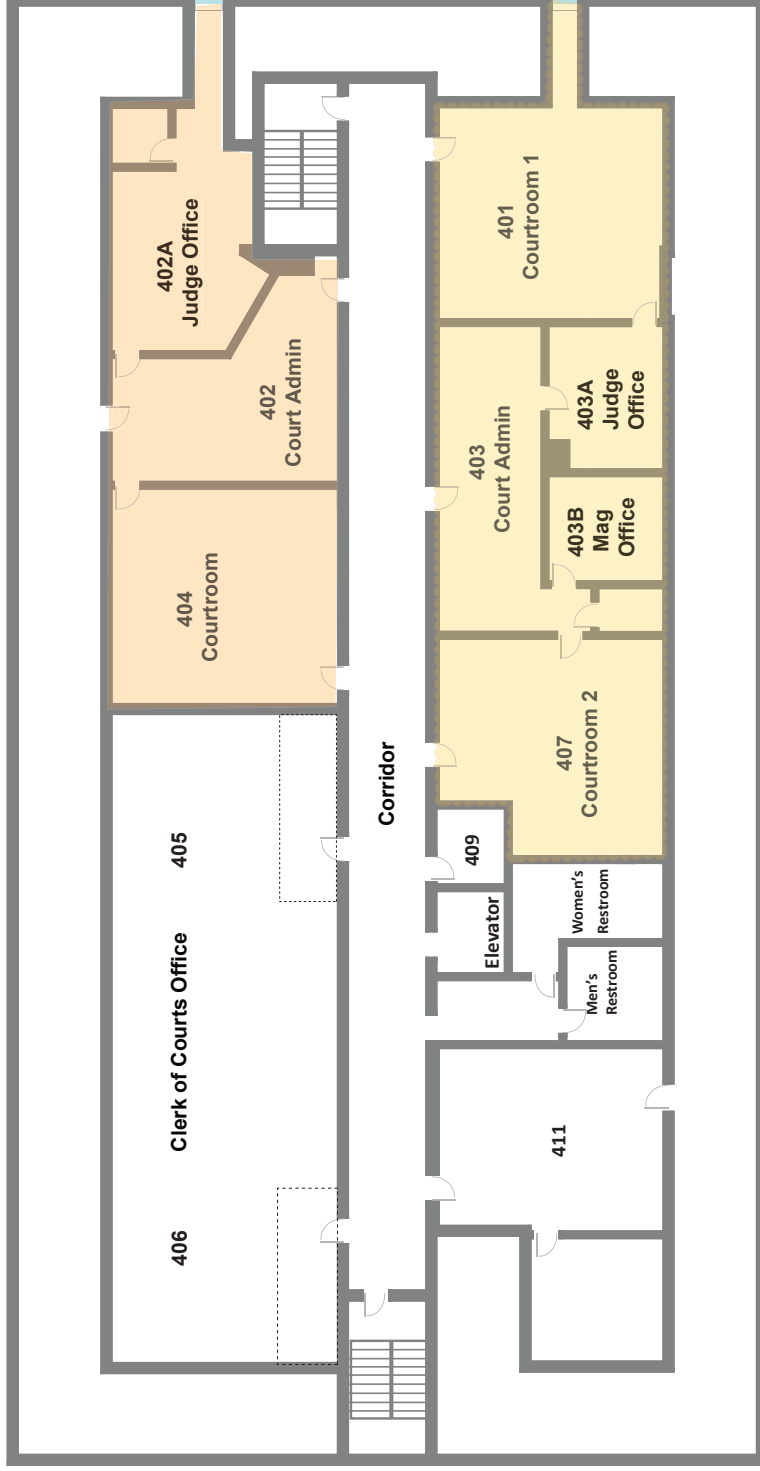

Fairfield County Hall of Justice
FOURTH FLOOR

ADDENDUM #1



(Advertisement)

FAIRFIELD COUNTY COMMISSIONERS

210 East Main Street
Lancaster, OH 43130

**INVITATION TO BID
for the
REPLACEMENT OF CARPET FLOORING**

Pursuant to ORC 307.87

The Fairfield County Commissioners are requesting bids for the REPLACEMENT OF CARPET FLOORING in the Hall of Justice located at 224 East Main Street, Lancaster, Ohio. The existing building is a four (4) story structure of approximately 43,000 S.F. in total size, with portions of that area to receive flooring replacement. Qualified Bidders shall have until 10:00 AM on May 10, 2024 to submit their bids to Dennis R. Keller, Deputy Director, 210 East Main Street, Room 300, Lancaster, Ohio, 43130. Bids will be publicly opened and read at 10:00 AM, on May 10, 2024 in the 3rd floor Commissioners Hearing Room, 210 East Main Street, Lancaster, Ohio.

Prospective Bidders are encouraged to attend a Pre-Bid Conference on Wednesday, May 1, 2024 at 10:00 AM, to be held at the jobsite located at 224 East Main Street, Lancaster, Ohio. Meet in the First Floor lobby using the Front Entrance Door.

Bids shall comply with the standards set forth in the Invitation to Bid (ITB) and floor plans posted for download on the Fairfield County website at: www.co.fairfield.oh.us. Printed copies are also available in the County Commissioners Office, 3rd Floor, 210 East Main Street, Lancaster, Ohio, during normal business hours. Each bid must be submitted in a sealed envelope, accompanied by the bid bond described in the ITB, and clearly marked on the outside of the envelope "Bid for CARPET FLOORING REPLACEMENT".

The Facilities Manager, County Administrator, and County Commissioners will evaluate all bids submitted to determine the lowest and best bid. The Fairfield County Commissioners reserve the right to reject any and all bids in response to this Invitation to Bid (ITB), and to waive any irregularities, nonconformities, or noncompliance with the terms of this ITB.

The Fairfield County Board of Commissioners is an Equal Opportunity Employer. Bidders are required to certify equal employment opportunity and drug-free workplace, among other certifications required in the bid documents.

The Owners Estimate of Cost is \$130,237.

This is a State Prevailing Wage Project.

Publication Date: April 18, 2024

End

From: [Brown-Thompson, Amy L](#)
To: [Keller, Dennis R](#)
Cc: [Kochis, Jon P](#)
Subject: RE: Bids for Carpet at Hall of Justice
Date: Friday, May 10, 2024 1:58:52 PM

Hi Dennis,

Based on what is presented, I am fine with the County rejecting Garretts' bid for being non-responsive.

Thanks!

Amy



Amy Brown Thompson
Civil Division Chief

Fairfield County Prosecutor's Office
239 West Main Street, Suite 101
Lancaster, Ohio 43130
(P) 740-652-7560 | (F) 740-653-4708
www.co.fairfield.oh.us/prosecutor

This transmission may contain confidential information intended only for the intended recipient(s). The information contained in this transmission may also be privileged and/or subject to attorney work-product protection. If you are not the intended recipient, any use, dissemination, distribution, or copying of this document or its contents is strictly prohibited. If you have received this e-mail in error, please immediately notify the sender by e-mail at the address above. The transmission is to be deleted and any items that may have been printed are to be destroyed.

From: Keller, Dennis R <dennis.keller@fairfieldcountyohio.gov>
Sent: Friday, May 10, 2024 12:24 PM
To: Brown-Thompson, Amy L <amy.brown-thompson@fairfieldcountyohio.gov>
Cc: Kochis, Jon P <jon.kochis@fairfieldcountyohio.gov>
Subject: Bids for Carpet at Hall of Justice

Amy –

I'm just looking for your confirmation, that the bid received this morning from Garretts Carpet Connection is non-responsive and cannot be accepted. Their bid submission did not include the bid bond, performance bond, or a list of references as required in Section 3 of the ITB.

Even though the bid from Levitate Flooring is \$800 higher, it does include all of the required documents in their bid submission.

I assume we can reject the low bid from Garretts and accept the bid from Levitate Flooring.

Please let me know, ASAP.

Dennis

Dennis R. Keller, AASCE
Deputy Director | Facilities Operations

 210 E. Main St.
Lancaster, OH
43130

 614-832-5250 (c)
740-687-6048 (f)



 <https://fairfieldcountyohio.gov>

 dennis.keller@fairfieldcountyohio.gov

ORIGINAL

Carri L. Brown, PhD, MBA, CGFM

Purchase Order

Fairfield County Auditor
210 East Main Street
Lancaster, Ohio 43130

Fiscal Year 2024

Page: 1 of 1

**THIS NUMBER MUST APPEAR ON ALL INVOICES,
PACKAGES AND SHIPPING PAPERS.**

Purchase Order # **24004555 - 00**

Delivery must be made within doors of specified destination.

Expiration Date: 03/15/2025

**B
I
L
L
T
O**

COUNTY COMMISSIONERS
210 E MAIN ST 3RD FLOOR
LANCASTER, OH 43130

Revisions: 000

**V
E
N
D
O
R**

LEVITATE PLUS FLOORING SYSTEMS
INC
13050 WATKINS RD
MARYSVILLE, OH 43040

**S
H
I
P
T
O**

MAINTENANCE DEPARTMENT
240 BALDWIN DRIVE
LANCASTER, OH 43130

VENDOR PHONE NUMBER	VENDOR FAX NUMBER	REQUISITION NUMBER	DELIVERY REFERENCE	
		5004		
DATE ORDERED	VENDOR NUMBER	DATE REQUIRED	FREIGHT METHOD/TERMS	DEPARTMENT/LOCATION
05/13/2024	16143			COMM-MAINTENANCE
NOTES				

PO Requisitioner Name : Emylee Noel Gussler
E mail Address : emylee.gussler@fairfieldcountyohio.gov

ITEM #	DESCRIPTION / PART #	QTY	UOM	UNIT PRICE	EXTENDED PRICE
1	CARPET @ HOJ GL Account: 12343500 - 570000	1.0	EACH	\$110,844.00	\$110,844.00
GL SUMMARY					
	12343500 - 570000			\$110,844.00	

Invoice Date ___/___/___ Invoice Amount \$ _____ To Be paid ___/___/___ Warrant # _____

COUNTY AUDITOR'S CERTIFICATE

It is hereby certified that the amount \$110,844.00 required to meet the contract, agreement, obligation, payment or expenditure, for the above, has been lawfully appropriated, authorized or directed for such purpose and is in the County Treasury or in process of collection to the credit of the submitted Fund(s) free from any obligation or certification now outstanding.

Date: 05/13/2024

Carri L. Brown

Auditor Fairfield County, OH

Purchase Order Total \$110,844.00

For Department Use ONLY

Prosecutor's Approval Page

Resolution No.

A Resolution Authorizing the Approval of a Contract Award for the Replacement of
Carpet Flooring – Hall of Justice Building

(Fairfield County Facilities)

Approved as to form on 5/17/2024 2:01:27 PM by Amy Brown-Thompson,



Amy Brown-Thompson
Prosecutor's Office
Fairfield County, Ohio

Signature Page

Resolution No. 2024-05.21.j

A Resolution Authorizing the Approval of a Contract Award for the Replacement of
Carpet Flooring, Hall of Justice Building

(Fairfield County Facilities)

This resolution has not yet been voted on.

CERTIFICATE OF CLERK

It is hereby certified that the foregoing is a true and correct transcript of a resolution acted
upon by the Board of County Commissioners, Fairfield County, Ohio on the date noted above.

A resolution to approve additional appropriations by appropriating from unappropriated into a major expense object category – Fund #7521 – Family Adult Children First

WHEREAS, appropriate from unappropriated into major expense category of Materials & Supplies for org#60818420 is necessary for the expenses; and

WHEREAS, we need additional appropriations in our Professional Services because we did not budget enough for Professional Services.

NOW THEREFORE, BE IT RESOLVED BY THE BOARD OF COUNTY COMMISSIONERS, COUNTY OF FAIRFIELD, STATE OF OHIO:

Section 1. Request that the Fairfield County Commissioners appropriate from unappropriated funds in the amount of \$10,720.71 for the major expense object categories:

60818420 Materials & Supplies \$10,720.71

For Auditor's Office Use Only:

Section 1.

60818420 560000 - \$10,720.71 Materials & Supplies

Prepared by: Morgan Fox, Fiscal Officer on behalf of FCFC

Signature Page

Resolution No. 2024-05.21.k

A Resolution to Approve Additional Appropriations by Appropriating from Unappropriated into a Major Expense Object Category, Fund #7521

(Fairfield County Family and Children First Council)

This resolution has not yet been voted on.

CERTIFICATE OF CLERK

It is hereby certified that the foregoing is a true and correct transcript of a resolution acted upon by the Board of County Commissioners, Fairfield County, Ohio on the date noted above.

A resolution to approve additional appropriations by appropriating from unappropriated into a major expense object category – Fund #7521 – Family Adult Children First

WHEREAS, appropriate from unappropriated into major expense category of Materials & Supplies for org#60815220 is necessary for the expenses; and

WHEREAS, we need additional appropriations in our Professional Services because we did not budget enough for Professional Services.

NOW THEREFORE, BE IT RESOLVED BY THE BOARD OF COUNTY COMMISSIONERS, COUNTY OF FAIRFIELD, STATE OF OHIO:

Section 1. Request that the Fairfield County Commissioners appropriate from unappropriated funds in the amount of \$3,700.00 for the major expense object categories:

60815220 Materials & Supplies \$3,700.00

For Auditor's Office Use Only:

Section 1.

60815220 560000 - \$3,700.00 Materials & Supplies

Prepared by: Morgan Fox, Fiscal Officer on behalf of FCFC

Signature Page

Resolution No. 2024-05.21.I

A resolution to approve additional appropriations by appropriating from unappropriated into a major expense object category – Fund #7521 – Family Adult Children First (Fairfield County Family and Children First Council)

This resolution has not yet been voted on.

CERTIFICATE OF CLERK

It is hereby certified that the foregoing is a true and correct transcript of a resolution acted upon by the Board of County Commissioners, Fairfield County, Ohio on the date noted above.

A Resolution Approving an Account-to-Account Transfer into a Major Expenditure Object Category – Fund # 7521, Family Children First Council

WHEREAS, appropriations are needed to cover expenses for 2024; and

WHEREAS, an account-to-account transfer will allow proper classification of major expenditure object categories.

NOW THEREFORE, BE IT RESOLVED BY THE BOARD OF COUNTY COMMISSIONERS, COUNTY OF FAIRFIELD, STATE OF OHIO:

Section 1. That the transfer of appropriations in the amount of \$6,720.72 is hereby authorized as follows:

From: 60818420, Materials & Supplies \$6,720.72

To: 607521000, Personal Services \$4,601.38
607521000, Fringe Benefits \$2,119.34

Prepared by: Morgan Fox, Fiscal Officer

2024-05.21.m

**Account-to-Account Transfer
For Auditor's Office Use Only:**

Total Transfer of Appropriations \$6,720.72

From: 60818420, 560000, Materials & Supplies; \$6,720.72
To: 607521000, 511010, Salary, Employees \$4,601.38
607521000, 521000, Health Insurance \$1,982.64
607521000, 521100, Life Insurance \$6.10
607521000, 522000, Medicare \$66.18
607521000, 523000, Retirement-PERS \$64.42

Signature Page

Resolution No. 2024-05.21.m

A Resolution Approving an Account-to-Account Transfer into a Major Expenditure Object Category, Fund #7521

(Fairfield County Family and Children First Council)

This resolution has not yet been voted on.

CERTIFICATE OF CLERK

It is hereby certified that the foregoing is a true and correct transcript of a resolution acted upon by the Board of County Commissioners, Fairfield County, Ohio on the date noted above.

A resolution to approve a plan agreement with the County Commissioners Association of Ohio for inclusion the workers' compensation group retrospective rating plan program

WHEREAS, Fairfield County currently participates in a group retrospective rating program through the County Commissioners Association of Ohio ("CCAO") for the Bureau of Workers' Compensation ("BWC") costs; and

WHEREAS, Fairfield County would like to continue to be a participating county in the group retrospective rating program offered by CCAO to manage costs associated with BWC coverage; and

WHEREAS, the County Prosecutor has approved the attached agreement as to form.

NOW THEREFORE, BE IT RESOLVED BY THE BOARD OF COUNTY COMMISSIONERS, COUNTY OF FAIRFIELD, STATE OF OHIO:

Section 1. The Board of Commissioners enters into the Plan Agreement for the CCAO Worker's Compensation Group Retrospective Rating Plan Program for the rating period beginning January 1, 2025, to December 31, 2025.

Section 2: The Clerk of the Board of Commissioners will furnish a certified copy of this resolution and the signed documents to the Deputy Fairfield County Administrator for further processing.

Prepared by: Abby Watson, Deputy HR Director

**COUNTY COMMISSIONERS ASSOCIATION OF OHIO
WORKERS' COMPENSATION GROUP RETROSPECTIVE RATING
PLAN AGREEMENT**

THIS AGREEMENT, dated as of _____, 2024, is between CCAO Service Corporation ("CCAOSC"), an Ohio corporation, and FAIRFIELD COUNTY ("Participant"), a political subdivision of the State of Ohio.

Section I: INTRODUCTION

Section 4123.29 of the Ohio Revised Code (ORC), and the rules promulgated thereunder, permit the establishment of employer group retrospective rating plans in order to group the experience of employers for workers' compensation rating purposes. The County Commissioners' Association of Ohio ("CCAO"), acting through CCAOSC its Service Corporation, as a sponsoring organization within the meaning of Section 4123.29 and the regulations associated with same, hereby establishes a Group Retrospective Rating Plan for the benefit of its membership. The terms and conditions for participation in the CCAO Group Retrospective Rating Plan are herein established.

A participating county is hereafter referred to individually as a "Participant". Participating counties are collectively referred to as the "Group".

Section II: NAME

The name of the plan shall be the CCAO Workers' Compensation Group Retrospective Rating Plan, hereafter referred to as the "CCAO Group Retrospective Rating Plan" or the "Plan". The principal office of the CCAO Group Retrospective Rating Plan shall be located at 209 East State Street, Columbus, Ohio 43215.

Section III: PURPOSE OF GROUP PLAN

The CCAO Group Retrospective Rating Plan is intended to: (1) achieve lower workers' compensation costs for the Group, and (2) result in the establishment of safer working conditions and environments for each Participant.

Section IV: REPRESENTATIONS AND WARRANTIES CONCERNING ELIGIBILITY

- A. CCAOSC, for itself and on behalf of CCAO, represents and warrants as follows:
- (1) CCAO was created more than two years prior to the date of application for Group coverage.
 - (2) CCAO was formed for the purposes other than obtaining Group Workers' Compensation under Section 4123.29, ORC; rather it was formed for the purpose of, among other things, uniting the county commissioners of Ohio into an association to promote the best practices and policies in the administration of county government for the benefit of the people of the State of Ohio.
 - (3) The business of the Group members is substantially similar such that the policies which are grouped are substantially homogeneous.
- B. The Participant represents and warrants as follows:
- (1) It is a member of the County Commissioners' Association of Ohio and is current in all financial obligations to CCAO.
 - (2) It has an Ohio Bureau of Workers' Compensation ("OBWC") policy number for counties and its account with OBWC has no outstanding premiums, penalties or assessments due from it.
 - (3) It is not a member of any other group for the purpose of obtaining workers' compensation coverage under Section 4123.29, ORC.
 - (4) It is current in all financial obligations to the Group.

Section V: BASIC OBLIGATIONS OF PARTIES

Pursuant to Section I, hereof, CCAO, acting through CCAOSC, has established the CCAO Group Retrospective Rating Plan.

A. CCAOSC shall:

- (1) coordinate and administer the CCAO Group Retrospective Rating Plan in accordance with this agreement.
- (2) file or cause to be filed all necessary applications with OBWC to obtain membership for the Participants in the CCAO Group Retrospective Rating Plan; and
- (3) perform such additional duties as are required of it by this Agreement.

B. The Participant shall:

- (1) join and participate in the CCAO Group Retrospective Rating Plan; and
- (2) perform such additional duties and pay such fees and expenses as are required of it by this Agreement.

Section VI: RATE CONTRIBUTION AND REBATES

The Participant understands that the Group performance must be estimated in advance of the experience period and is based upon the most recent experience period, and that the actual Group performance will vary depending upon multiple factors. The Participant is solely responsible for any assessment of premiums owed to the OBWC. In no event shall CCAO, CCAOSC, the third party administrator, or other Group members be held liable for premiums owed by the Participant to the OBWC.

The Participant understands the Group performance is subject to change during and subsequent to the policy period, and all debit and credit adjustments processed by the OBWC will be the premium responsibility of the individual Participant. In no event will CCAO, CCAOSC, the third party administrator, or the other Group members be held liable for premiums owed by the Participant to the OBWC resulting from subsequent rate revisions.

It is understood that the OBWC will evaluate the performance of the CCAO Group Retrospective Rating Plan by comparing the aggregate individual participants' premiums paid to OBWC to the developed losses incurred by the participants during the policy year. It is also understood that the OBWC will perform this comparison in three periods in the following number of months after the inception of the program year: 24 months, 36 months, and 48 months.

In the course of the OBWC's evaluation of the program, should premiums paid by the Group exceed the total developed losses, the Group will be entitled to a refund for the difference. However, if the total developed losses exceed the total premiums paid to OBWC for the policy year the Group would then be subject to an assessment. The total assessment in this case, could not exceed the predetermined amount ("Maximum Premium Percent") selected by the group Executive Committee. For each evaluation period, payment of refund or notice of assessment to each Participant will be made by the OBWC pursuant to OBWC rules and procedures.

Section VII: ADMINISTRATIVE SERVICES

CCAOSC shall retain the services of a third party administrator ("TPA") specializing in the administration of workers' compensation claims. Such designated TPA shall assist CCAOSC staff in the day to day management of the plan, prepare and file necessary reports for both OBWC and members, assist with loss control program, and other duties, (*excluding* claims-related matters, which shall be the responsibility of each individual Participant, as provided in the second paragraph of this Section VII) relating to the Plan's activities. The cost of these TPA services, and the administrative costs of CCAOSC, shall be borne by the Participant in proportion to its payroll to the total payroll of the Group. CCAOSC shall bill the Participant for such services at such times as are determined by the Group Executive Committee and the Participant shall remit payment to CCAOSC within thirty (30) days of its receipt of such bill.

Each Participant agrees to engage, at its sole expense, a TPA for claims-related matters, the same TPA as

CCAOSC has retained as TPA for the Group, and further agrees to remain with said TPA for as long as Participant remains a member of the CCAO Group Retrospective Rating Plan.

In any event, the Participant agrees to inform CCAOSC, the Group, and the Group's TPA, at all times, of all claims and related matters which will affect the rating of the Group.

Section VIII: RISK MANAGEMENT SERVICES

The Participant acknowledges that one of the goals of a group retrospective rating program is a substantial improvement in accident prevention and safety training by the Group. The Participant shall make a good faith effort to maintain a safe working environment for its employees and to implement the Group's model safety and claims management program, "*The CCAO 10 Step Safety Plan for County Government*". In addition, each Participant shall participate in and comply with any safety program or claims management procedure adopted by the Group Executive Committee, including, but not limited to, completing the Claims Management and Safety Expectations Survey and working toward accomplishing all of the Claims Management and Safety Expectations. The costs for these risk management services shall be allocated, billed and paid in the same manner as described in Section VII, above. The Participant may provide supplementary training and risk management consulting services to its employees at the Participant's sole expense.

CCAOSC reserves the right to require the Participant to undergo an occupational safety and health audit of its premises. A copy of the audit results and safety recommendations shall be provided to the Participant and to CCAOSC. Participant agrees to make a good faith effort to comply with any safety recommendations.

Section IX: GENERAL ADMINISTRATIVE FEES

The Participant agrees to pay the administrative fees of CCAOSC during the term of the Agreement, if any, in the manner specified in Section VII, above.

Section X: GROUP ADVISORY COMMITTEE

There is hereby established a Group Advisory Committee to advise CCAOSC regarding the CCAO Group Rating Program and the CCAO Group Retro Program, which shall consist of seven members. Two of said members shall be the President and the Secretary/Treasurer of CCAOSC. Five members shall be representatives of CCAO Group Rating and Group Retro Plan Participants. No Participant shall have more than one member on the Group Advisory Committee, and each Advisory Committee Member shall be a county commissioner. However, any member county may by written instrument signed by two or more County Commissioners, appoint a designee who need not be a county commissioner but shall be an employee of the member county. A designee shall have the same powers as the appointing member.

The duties of the Group Advisory Committee shall be:

- (1) to advise CCAOSC on the selection of a TPA, as provided in Section VII hereof;
- (2) to advise CCAOSC on proposed TPA fees, fees for risk management services, general administrative fees, and the billing and collection thereof;
- (3) to confer with CCAOSC on the ongoing eligibility of each Participant for continued participation in the Group; and
- (4) to perform such other acts and functions as may be necessary to the administration of the Group.

Section XI: TERM OF AGREEMENT

Subject to the approval of the CCAO Group Retrospective Rating Plan by the OBWC, the term of this Agreement shall commence on the date of execution hereof and shall be continuing and shall be applicable to all rating periods beginning January 1, 2025 and thereafter. CCAOSC may terminate this Agreement upon thirty (30) days written notice to the Participant. The Participant may terminate this Agreement so as not to be included in the CCAO Group Retrospective Rating Plan for the next annual rating period provided ten (10) days written notice of intent to withdraw from the CCAO Group Retrospective Rating Plan is given to CCAOSC prior to the prescribed application deadline of OBWC, currently July 31, 2024. In any event, a Participant shall not be relieved of the obligation to pay any amounts owed for participation in the CCAO Group Retrospective Rating Plan prior to withdrawal therefrom.

Section XII: APPLICATIONS BY PARTICIPANT

Initial application of a Participant shall include: (1) a properly signed and authorized copy of this Agreement; and (2) a properly executed OBWC Form U153, allowing CCAOSC or its TPA to represent the CCAO Group Retrospective Rating Plan before the OBWC. In order to remain eligible for Group membership, a Participant must be current in all financial obligations to CCAO and to the Group, and shall provide to CCAOSC annually, prior to the OBWC group retrospective rating deadline: (1) a properly signed and authorized copy of this Agreement; and (2) a properly executed OBWC U153, allowing CCAOSC or its TPA to represent the CCAO Group Retrospective Rating Plan before the OBWC.

Section XIII: GENERAL PROVISIONS

CCAOSC shall strictly account for all funds collected and disbursed relating to the Group Retrospective Rating Plan. All Group Retrospective Rating Plan funds shall be strictly segregated from all CCAOSC funds relating to the operations and activities of CCAO's other programs.

The Participant is solely responsible for any assessments or premiums levied by OBWC against it. Neither the CCAO Group Retrospective Rating Plan nor its TPA shall be liable for any such charges.

If the Participant leaves the Group, it will allow representatives of the Group to access its loss experience for a period of three (3) years following the last year of participation.

Section XIV: ANTI-DISCRIMINATION PROVISION

Per section 125.111(A) of the Ohio Revised Code, CCAOSC warrants and agrees to the following:

A. In the hiring of employees for the performance of work under this Agreement or any subcontract hereunder, neither CCAOSC or any subcontractor, by reason of race, color, religion, sex, age, disability or military status as defined in section 4112.01 of the Revised Code, national origin, or ancestry, shall discriminate against any citizen of the State of Ohio in the employment of a person qualified and available to perform the work to which such contract relates; and

B. None of CCAOSC, any subcontractor, or person acting on behalf of any such organization, in any manner, shall discriminate against, intimidate, or retaliate against any employee hired for the performance of work under the contract on account of race, color, religion, sex, age, disability, or military status as defined in section 4112.01 of the Revised Code, national origin, or ancestry.

The Participant hereby acknowledges receipt of the complete Agreement.

IN WITNESS THEREOF, the parties hereby enter into this Agreement on the date given below.

CCAO SERVICE CORPORATION

Date: 3/19/2024

By: 
John Leutz, CCAO Assistant Director

FAIRFIELD COUNTY

Date: _____

By: _____
Signature of Authorized Official

County Name: FAIRFIELD COUNTY

Address: 210 E MAIN STREET

City, State, Zip: LANCASTER OH 43130

OBWC Number: 32300001

APPROVED AS TO FORM (if required)

Prosecuting Attorney

Prosecutor's Approval Page

Resolution No.

A resolution to approve a plan agreement with the County Commissioners Association of Ohio for inclusion the workers' compensation group retrospective rating plan program

(Fairfield County Human Resources)

Approved as to form on 5/17/2024 2:25:04 PM by Amy Brown-Thompson,



Amy Brown-Thompson
Prosecutor's Office
Fairfield County, Ohio

Signature Page

Resolution No. 2024-05.21.n

A Resolution to Approve a Plan Agreement with the County Commissioners Association of Ohio for Inclusion, the Workers' Compensation Group Retrospective Rating Plan Program

(Fairfield County Human Resources)

This resolution has not yet been voted on.

CERTIFICATE OF CLERK

It is hereby certified that the foregoing is a true and correct transcript of a resolution acted upon by the Board of County Commissioners, Fairfield County, Ohio on the date noted above.

A resolution authorizing the approval of a Shared Family Foster Home Agreement by and between Fairfield County Job & Family Services, Child Protective Services Division and South Central Ohio Job and Family Services and Fairfield County Protective Services

WHEREAS, Fairfield County Job & Family Services, Protective Services is requesting the Board of Commissioners approval of a Shared Family Foster Home Agreement with South Central Ohio Job and Family Services, 475 Western Ave. Suite B, Chillicothe, Ohio 45601; and

WHEREAS, the purpose of the agreement is to provide Licensed Family Foster Home Placement and Related Services for children who are in the care and custody of the Agency; and

WHEREAS, this agreement shall be effective beginning April 1st, 2024; and

WHEREAS, a purchase order encumbering the funds for the services was acquired; and

WHEREAS, the Prosecuting Attorney has approved the agreement as to form.

NOW THEREFORE, BE IT RESOLVED BY THE BOARD OF COUNTY COMMISSIONERS, COUNTY OF FAIRFIELD, AND STATE OF OHIO:

Section 1. That the Fairfield County Board of Commissioners hereby approves the attached Shared Family Foster Home Agreement for South Central Ohio Job and Family Services and Fairfield County Protective Services.

Prepared by: Brandi Downhour
cc: JFS / Budget Manager

ROUTING FORM FOR CONTRACTS

The undersigned designee of the County affirms that he/she has reviewed the attached contract to ensure that it complies with County's needs and previous negotiations. The undersigned designee further affirms that the County has complied with the competitive selection process, as prescribed by Ohio Revised Code 9.17, and the applicable sections as outlined on this form, by selecting the applicable boxes below.

- A. Goods and/or Services in excess of \$75,000.00—competitively selected via an Invitation to Bid, pursuant to R.C. 307.86-307.92
- B. Goods and/or Services in excess of \$75,000.00—competitively selected via a Request for Proposals, pursuant to R.C. 307.862
- C. Public Improvement contracts—competitively selected pursuant to R.C. 153.08-153.12
- D. Architect/Engineer design services for public improvements—selected through the Request for Qualifications process pursuant to R.C. 153.65-153.72
- E. County Road Improvement/Construction—competitively selected pursuant to R.C. 5555.61
- F. The subject matter was exempt from competitive selection for the following reason(s):
- Under \$75,000
 - State Term #: _____ (copy of State Term Contract must be attached)
 - ODOT Term #: _____ (See R.C. 5513.01)
 - Professional Services (See the list of exempted occupations/services under R.C. 307.86)
 - Emergency (Follow procedure under ORC 307.86(A))
 - Sole Source (attach documentation as to why contract is sole source)
 - Other: _____ (cite to authority or explain why matter is exempt from competitive bidding)
- G. Agreement not subject to Sections A-F (explain): _____
- H. Compliance with Fairfield County Board of Commissioners Procurement Guidelines
- No County employee, employee's family member, or employee's business associate has an interest in this contract OR such interest has been disclosed and reviewed by the Prosecutor's Office
 - No Finding for Recovery against Vendor as required under R.C. 9.24 (search via "Certified Search" on <http://ffr.ohioauditor.gov/>)
 - Obtained 3 quotes for purchases under \$75,000 (as applicable)
 - Purchase Order is included with Agreement

Signed this _____ day of _____, 20_____.

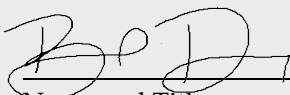

Brandi Downhour, Budget Manager

Name and Title

*** Please note that this checklist only addresses County and statutory requirements. If a contract is paid for with state and/or federal funds, please consult with the appropriate state and/or federal agency to ensure your department is complying with any additional requirements. By submitting a request for approval, you are certifying you have addressed County, statutory, and grant requirements.***

Shared Foster Home Agreement

The following agreement is entered into by South Central Ohio Job and Family Services and Fairfield County Job and Family Services.

The lending agency, South Central Ohio Job and Family Services, Children's Division, agrees to the following:

1. Retain responsibility for the recertification process,
2. Share the foster home record with the borrowing agency,
3. Keep the borrowing agency informed of any significant changes in the foster home.

The borrowing agency, Fairfield County Job and Family Services, agrees to the following:

1. Obtain the approval of the lending agency prior to contacting the foster family regarding placement, Serenaty Henley.
2. Maintain responsibility for paying the board rate of \$35 for Serenaty Henley per day plus provide a minimum wardrobe upon placement, a clothing allotment for spring, summer, fall, and winter, and pay all necessary expenses for the foster child(ren) for medical, dental care, eye exams, school fees, and provide for psychological and/or educational testing when appropriate.
3. Reimburse foster parent mileage expenses at the rate of 65.5 cents per mile for non-routine appointments.
4. Maintain responsibility for supervising the child in placement, according to the substitute care rules of the Ohio Administrative Code.
5. Prior to the expiration of the agreement, submit an evaluation of the foster family's abilities with the child(ren) in placement and an estimate of the length of time the placement is expected to continue.
6. Provide the name of the caseworker and the 24 hour agency emergency number.



Jody Walker, Executive Director

475 Western Ave. Suite B Chillicothe, Ohio 45601

The foster family Austin and Brandon Miller, agrees to the following:

1. Agrees that the placement of a child by an outside agency requires prior approval of the lending agency,
2. Agrees to care for Serenaty Henley as a foster child,
3. Contact the agency holding custody of the child when problems occur,
4. Accept the borrowing agency's involvement and responsibility for the child in placement,
5. Notify the lending agency, South Central Ohio Job and Family Services, Children's Division, if the borrowing agency, Fairfield County Job and Family Services, is not accepting responsibility for the terms specified in this agreement.

This authorization is valid commencing April 29, 2024.

Signatures

 _____ Date 4/29/24
 South Central Ohio Job and Family Services

 Fairfield County Job and Family Services Date _____

 Foster Parent Date _____

 Foster Parent Date _____



A Contract regarding Shared Home Agreement-SCOJFS between Job and Family Services and

Approved on 5/6/2024 3:36:51 PM by Sarah Fortner, Deputy Director

Sarah Fortner
Deputy Director

Approved on 5/6/2024 4:08:11 PM by Corey Clark, Director of Fairfield County Job & Family Services

Corey Clark, Director
Fairfield County Job & Family Services

Cost Analysis

For foster care placement, network providers have Title IV-E reimbursement ceilings, and Fairfield County rates have typically been below the state negotiated ceilings. Historically, the traditional, daily rate is less than \$225. The total cost of this agreement is not expected to exceed an average of \$35 a day per-diem.

Prosecutor's Approval Page

Resolution No.

A resolution authorizing the approval of a Shared Family Foster Home Agreement by and between Fairfield County Job & Family Services, Child Protective Services Division and South Central Ohio Job and Family Services and Fairfield County Protective Services

(Fairfield County Job and Family Services)

Approved as to form on 5/13/2024 11:21:55 AM by Steven Darnell,

Signature Page

Resolution No. 2024-05.21.o

A Resolution Authorizing the Approval of a Shared Family Foster Home Agreement by and between Fairfield County Job & Family Services, Child Protective Services Division and South Central Ohio Job and Family Services and Fairfield County Protective Services

(Fairfield County Job and Family Services)

This resolution has not yet been voted on.

CERTIFICATE OF CLERK

It is hereby certified that the foregoing is a true and correct transcript of a resolution acted upon by the Board of County Commissioners, Fairfield County, Ohio on the date noted above.

A resolution to approve a memo exp./ memo receipt for the costs of Birth Certificates paid to Fairfield County Health Departments as a memo expenditure for fund# 2072 Public Children's Services

WHEREAS, FCJFS is responsible for paying the Health Department for their Birth Certificate costs; and

NOW THEREFORE, BE IT RESOLVED BY THE BOARD OF COUNTY COMMISSIONERS, COUNTY OF FAIRFIELD, STATE OF OHIO:

Section 1: That the Fairfield County Auditor reflect the following memo receipt:

71700300- 434410 Reimbursement - \$64.00

This amount represents monies owed to the Health Department for FCJFS's costs paid to the Health Department as denoted in the attached documentation.

Section 2: That the Fairfield County Board of Commissioners approves the following expenditure of other expenses and requests that the Fairfield County Auditor accomplish the transaction as if a regular County Auditor warrant reimbursing the Health Department for FCJFS's Birth Certificate costs.

Memo expenditure as referenced in supporting documentation:

Vendor # 7482 Fairfield County Health Department

Account: 12207207-533000 Other Professional Services

Amount: \$64.00

Prepared by: Morgan Fox, Fiscal Officer

cc: Jamie Ehorn, Fairfield County Health Department

Signature Page

Resolution No. 2024-05.21.p

A Resolution to Approve a Memo Expense/Memo Receipt for the Costs of Birth Certificates Paid to Fairfield County Health Departments as a Memo Expenditure for Fund #2072 Public Children's Services

(Fairfield County Job and Family Services)

This resolution has not yet been voted on.

CERTIFICATE OF CLERK

It is hereby certified that the foregoing is a true and correct transcript of a resolution acted upon by the Board of County Commissioners, Fairfield County, Ohio on the date noted above.

A resolution to approve additional appropriations by appropriating from unappropriated into a major expense object category – Fund # 2599 – Workforce Fund - Fairfield County JFS

WHEREAS, appropriate from unappropriated into major expense category of Contractual Services for org# 12259907 is necessary for the expenses; and

WHEREAS, we need more appropriations in our Contractual Services for expenses that the agency needs paid.

NOW THEREFORE, BE IT RESOLVED BY THE BOARD OF COUNTY COMMISSIONERS, COUNTY OF FAIRFIELD, STATE OF OHIO:

Section 1. Request that the Fairfield County Commissioners appropriate from Unappropriated funds in the amount of \$25,000.00 for the major expense object categories:

122259907 Contractual Services \$25,000.00

For Auditor's Office Use Only:

Section 1.

122259907 550000 Other Purchased Services \$25,000.00

Prepared by: Morgan Fox, Fiscal Officer

Signature Page

Resolution No. 2024-05.21.q

A resolution to approve additional appropriations by appropriating from unappropriated into a major expense object category – Fund # 2599 – Workforce Fund - Fairfield County JFS

(Fairfield County Job and Family Services)

This resolution has not yet been voted on.

CERTIFICATE OF CLERK

It is hereby certified that the foregoing is a true and correct transcript of a resolution acted upon by the Board of County Commissioners, Fairfield County, Ohio on the date noted above.

A resolution authorizing the approval of Amendment #2 to the FY24 Grant Agreement between Fairfield County Juvenile Court and Ohio Department of Youth Services.

WHEREAS, Fairfield County Juvenile Court is the recipient of a Subsidy Grant from the Department of Youth Services; and

WHEREAS, an amendment is required for the FY24 Grant Year; and

WHEREAS, Judge Terre L. Vandervoort, Fairfield County Juvenile Court, has approved said amendment and request the approval of the Commissioners.

NOW THEREFORE, BE IT RESOLVED BY THE BOARD OF COUNTY COMMISSIONERS, COUNTY OF FAIRFIELD, STATE OF OHIO:

Section 1. That the Juvenile Court Grant Amendment with the Ohio Department of Youth Services for the period of July 1, 2023 to June 30, 2024 is hereby approved.

Prepared by: Alisha Hoffman

cc: Juvenile Court

Amendment Form / Fiscal Accountability
(To Replace Attachment A Page 1 of the Grant Agreement)

County: <u>Y24 FAIRFIELD 05.16.24</u>	Amendment #	<u>FAIRFIELD #2</u>
Allocations		
FY 2024 Tentative Base Allocation (YSG/510)	(1A)	\$ 220,408.00
FY 2024 Tentative Variable Allocation (RECLAIM/401)	(2A)	\$ 644,708.48
FY 2024 Supplemental RECLAIM Allocation	(3A)	\$ _____
FY 2024 Targeted RECLAIM Allocation	(4A)	\$ _____
FY 2024 Competitive RECLAIM Allocation	(5A)	\$ 140,500.00
FY 2024 JDAI Allocation	(6A)	\$ _____
FY 2024 Y/E EVB Program Development Allocation	(7A)	\$ 225,000.00
FY 2024 Behavioral Health/Juvenile Justice (BHJJ)	(8A)	\$ _____
Allocations Subtotal	(A)	\$ 1,230,616.48
Tentative Carryover Balance as of 6/30/23 and Carryover Limit		
Subsidy Grant Carryover (YSG + RECLAIM)*	(1B)	\$ 60,535.28
Targeted RECLAIM Carryover	(2B)	\$ _____
Competitive RECLAIM Carryover	(3B)	\$ 65,125.26
JDAI Carryover	(4B)	\$ _____
Y/E EVB Program Development Carryover (include any former HB-153 Funds)	(5B)	\$ 133,485.26
Behavioral Health/Juvenile Justice (BHJJ)	(6B)	\$ _____
Tentative Carryover Subtotal	(B)	\$ 259,145.80
Carryover Limit	(C)	\$ 192,612.92
<i>(25% of Total FY 2022 RECLAIM and Youth Services Grant Allocations)</i>		
Exemptions		
Subsidy Grant Carryover Exemption (YSG + RECLAIM)*	(1D)	\$ _____
Targeted RECLAIM Exemption	(2D)	\$ _____
Competitive RECLAIM Exemption	(3D)	\$ 65,125.26
JDAI Exemption	(4D)	\$ _____
Y/E EVB Program Development	(5D)	\$ 133,485.26
Behavioral Health/Juvenile Justice (BHJJ)	(6D)	\$ _____
Total Exemptions	(D)	\$ 198,610.52
Withholdings		
Subsidy Grant (YSG + RECLAIM)*	(1E)	\$ _____
Targeted RECLAIM	(2E)	\$ _____
Competitive RECLAIM	(3E)	\$ _____
JDAI	(4E)	\$ _____
Y/E EVB Program Development	(5E)	\$ _____
Behavioral Health/Juvenile Justice (BHJJ)	(6E)	\$ _____
Withholding Estimate (to be withheld from FY 2024 payments)	(E)	\$ -
Available Program Funds		
Subsidy Grant (YSG + RECLAIM)*	(1F)	\$ 925,651.76
Targeted RECLAIM	(2F)	\$ _____
Competitive RECLAIM	(3F)	\$ 205,625.26
JDAI	(4F)	\$ _____
Y/E EVB Program Development	(5F)	\$ 358,485.26
Behavioral Health/Juvenile Justice (BHJJ)	(6F)	\$ _____
Total Available FY 2024 Program Funds	(F)	\$ 1,489,762.28
Estimated Program Costs		
Subsidy Grant Estimated Program Costs (YSG & RECLAIM)*	(1G)	\$ 801,488.35
Targeted RECLAIM Estimated Program Costs	(2G)	\$ _____
Competitive RECLAIM Estimated Program Costs	(3G)	\$ 135,125.26
JDAI Estimated Program Costs	(4G)	\$ _____
Y/E EVB Program Development Costs	(5G)	\$ 74,888.33
Behavioral Health/Juvenile Justice (BHJJ)	(6G)	\$ _____
Total Estimated FY 2024 Expenditures	(G)	\$ 1,011,501.94
Unallocated Funds		
Subsidy Grant Unallocated (YSG & RECLAIM)*	(1H)	\$ 124,163.41
Targeted RECLAIM Unallocated	(2H)	\$ _____
Competitive RECLAIM Unallocated	(3H)	\$ 70,500.00
JDAI Unallocated	(4H)	\$ _____
Y/E EVB Program Development Unallocated	(5H)	\$ 283,596.93
Behavioral Health/Juvenile Justice (BHJJ)	(6H)	\$ _____
Total Unallocated FY 2024 Funds	(H)	\$ 478,260.34
<i>* Supplemental Allocation included in RECLAIM amount</i>		

Staff Positions Budget Form

COUNTY: ELD FY24 AMENDMENT#2 0

FUNDING CATEGORY: Subsidy Grant

Activity Purpose: Behavioral Change Hybrid

LOCAL PROGRAM / ACTIVITY NAME: DIVERSION 1 OF 2

Name	Title	New or Existing	Number of Hours	Hourly Rate	Total
<u>PATRICK EPLER</u>	<u>DEPUTY DIRECTOR DIVERSION/QA</u>	<u>EXISTING</u>	<u>1040</u>	<u>40.82</u>	<u>\$ 42,452.80</u>
			<u>640</u>	<u>42.86</u>	<u>\$ 27,430.40</u>
<u>JOSEPH BENNETT</u>	<u>DIVERSION COORDINATOR</u>	<u>EXISTING</u>	<u>1040</u>	<u>31.31</u>	<u>\$ 32,562.40</u>
			<u>1040</u>	<u>32.88</u>	<u>\$ 34,195.20</u>
<u>KAYLA HITTLE-MARTINEZ</u>	<u>LEAD CASE MANAGER</u>	<u>EXISTING</u>	<u>1040</u>	<u>25.31</u>	<u>\$ 26,322.40</u>
			<u>1040</u>	<u>26.07</u>	<u>\$ 27,112.80</u>
<u>TARA COCKERHAM</u>	<u>CASE MANAGER</u>	<u>EXISTING</u>	<u>1040</u>	<u>28.02</u>	<u>\$ 29,140.80</u>
			<u>1040</u>	<u>28.86</u>	<u>\$ 30,014.40</u>
<u>AMANDA ENDERLE</u>	<u>CASE MANAGER</u>	<u>EXISTING</u>	<u>1040</u>	<u>24.46</u>	<u>\$ 25,438.40</u>
			<u>1040</u>	<u>25.19</u>	<u>\$ 26,197.60</u>
TOTAL STAFF POSITIONS					<u>\$ 300,867.20</u>
Fringe Benefits					
Type	<u>*OPERS</u>			<u>\$ 65,671.00</u>	
Type	<u>*HEALTH INS/EAP</u>			<u>\$ 119,871.00</u>	
Type	<u>*WORKERS COMP</u>			<u>\$ 7,037.00</u>	
Type	<u>*MEDICARE</u>			<u>\$ 6,802.00</u>	
Type	<u>*LIFE INS</u>			<u>\$ 306.00</u>	
TOTAL FRINGE BENEFITS					<u>\$ 199,687.00</u>
TOTAL STAFF and FRINGE BENEFITS					<u>\$ 500,554.20</u>
Budget Narrative - Describe the services that the positions will provide.					
<u>DIVERSION CASE MANAGERS OFFER DIVERSION ACCOUNTABILITY PROGRAM SERVICES WHICH PRIMARILY FOCUS ON ALTERNATIVES TO THE YOUTH BEING FORMALLY CHARGED AND/OR GOING THROUGH THE PROCESS OF THE TRADITIONAL, MORE LENGTHY MEANS OF THE JUVENILE JUSTICE SYSTEM.</u>					
<u>*FRINGE BENEFITS IS INCLUSIVE OF ALL DIVERSION STAFF, TOTAL OF 9. ADDITIONAL SALARY DETAIL FOUND ON PAGE 1 OF 2 STAFF BUDGET FORM.</u>					

Purchased or Contract Services Budget Form

COUNTY: FIELD FY24 AMENDMENT#2 05.

FUNDING CATEGORY: Subsidy Grant

Activity Purpose: Behavioral Change Hybrid

LOCAL PROGRAM / ACTIVITY NAME: DIVERSION 1 OF 2

<u>Agency Name/Individual (List all Providers by Name)</u>	<u>Public/ Private</u>	<u>Services to be provided</u>	<u>Quantity</u>	<u>Unit Costs</u>	<u>Total</u>
LISA KANDRA	PRIVATE	FACILITATION OF ASSESSMENTS/GROUPS	1	\$ 15,000.00	\$ 15,000.00
Total Purchased or Contract Services					\$ 15,000.00

Note: If the services to be provided are out-of-home placement, the facilities must either be approved by the Department of Youth Services per the minimum standards or licensed by the authorized state agency.

Program Maintenance Costs Budget Form

COUNTY: FAIRFIELD FY24 AMENDMENT#2 05.06.24

FUNDING CATEGORY: Subsidy Grant

Activity Purpose: Behavioral Change Hybrid

LOCAL PROGRAM / ACTIVITY NAME: DIVERSION 1 OF 2

<u>Item Description</u>	<u>Quantity</u>	<u>Unit Cost</u>	<u>Total</u>	<u>Briefly explain the reason needed.</u>
<u>ORBIS</u>	<u>1</u>	<u>\$ 1,425.00</u>	<u>\$ 1,425.00</u>	<u>MENTAL HEALTH SCREENING TOOL</u>
<u>FOOD AND SNACKS</u>	<u>1</u>	<u>\$ 3,112.00</u>	<u>\$ 3,112.00</u>	<u>FOOD/SNACKS FOR YOUTH AND/OR FAMILY</u>
Total Maintenance Costs			\$ 4,537.00	

Note: If the services to be provided are out-of-home placement, the facilities must either be approved by the Department of Youth Services per the minimum standards or licensed by the authorized state agency.

Program Equipment Budget Form

COUNTY: FAIRFIELD FY24 AMENDMENT#2 05.06.24

FUNDING CATEGORY: Subsidy Grant

Activity Purpose: Behavioral Change Hybrid

LOCAL PROGRAM / ACTIVITY NAME: DIVERSION 1 OF 2

<u>Item Description</u>	<u>Quantity</u>	<u>Unit Cost</u>	<u>Total</u>	<u>Briefly explain the reason needed.</u>
PC TOWER AND ACCESSORI	1	\$ 4,540.67	\$ 4,540.67	PC TOWER AND ACCESSORIES REPLACEMENT
TABLET AND ACCESSORIES	1	\$ 6,546.00	\$ 6,546.00	TABLET AND ACCESSORIES REPLACEMENT FOR FIEL
Total Equipment Costs			\$ 11,086.67	

Note: Equipment is defined as items that cost \$500.00 or more and have a useful life of more than one year.

Staff Positions Budget Form

COUNTY: ELD FY24 AMENDMENT#2 0

FUNDING CATEGORY: Subsidy Grant

Activity Purpose: Behavioral Change Hybrid

LOCAL PROGRAM / ACTIVITY NAME: DIVERSION 2 OF 2

Name	Title	New or Existing	Number of Hours	Hourly Rate	Total
WENDY HALE	CASE MANAGER	EXISTING	1040	23.63	\$ 24,575.20
TOTAL INCLUDES PAYOUT			680	24.81	\$ 16,870.80
LUCAS STEMEN	CASE MANAGER	EXISTING	1040	23.29	\$ 24,221.60
			345.25	23.52	\$ 8,120.28
ZACHARY BOWEN	CASE MANAGER	EXISTING	800	22.83	\$ 18,264.00
			1040	23.51	\$ 24,450.40
BROOKE WOODS	CASE MANAGER	EXISTING	1040	23.63	\$ 24,575.20
			1040	24.34	\$ 25,313.60
LESLIE GLENN	CASE MANAGER	NEW	80	22.83	\$ 1,826.40
TOTAL STAFF POSITIONS					\$ 168,217.48

Fringe Benefits

Type	<u>*OPERS</u>	_____	
Type	<u>*HEALTH INS/EAP</u>	_____	
Type	<u>*WORKERS COMP</u>	_____	
Type	<u>*MEDICARE</u>	_____	
Type	<u>*LIFE INS</u>	_____	
TOTAL FRINGE BENEFITS			_____
TOTAL STAFF and FRINGE BENEFITS			\$ 168,217.48

Budget Narrative - Describe the services that the positions will provide.

DIVERSION CASE MANAGERS OFFER DIVERSION ACCOUNTABILITY PROGRAM SERVICES WHICH PRIMARILY FOCUS ON ALTERNATIVES TO THE YOUTH BEING FORMALLY CHARGED AND/OR GOING THROUGH THE PROCESS OF THE TRADITIONAL MORE LENGTHY MEANS OF THE JUVENILE JUSTICE SYSTEM.

*SEE PAGE 1 OF 2 FOR FRINGE BENEFIT TOTAL, INCLUSIVE OF ALL DIVERSION STAFF

Staff Positions Budget Form

COUNTY: LD FY24 AMENDMENT #2

FUNDING CATEGORY: Y/E EVB Program Development

Activity Purpose: Behavioral Change Hybrid

LOCAL PROGRAM / ACTIVITY NAME: RESOURCE CENTER

Name	Title	New or Existing	Number of Hours	Hourly Rate	Total
OLIVIA REVELS-STROTHER	RESOURCE CENTER SPECIALIST	EXISTING	80	23.63	\$ 1,890.40
	VACATION & COMP TIME PAYOUT		1	150.53	\$ 150.53
ZOE FRYE	RESOURCE CENTER SPECIALIS	NEW	560	22.83	\$ 12,784.80
			680	22.83	\$ 15,524.40
JUSTIN CARPENTER	RESOURCE CENTER SPECIALIST	NEW	240	22.83	\$ 5,479.20
TOTAL STAFF POSITIONS					\$ 35,829.33

Fringe Benefits

Type	OPERS	\$ 5,004.00	
Type	HEALTH INS/EAP	\$ 15.00	
Type	WORKERS COMP	\$ 559.00	
Type	MEDICARE	\$ 521.00	
Type	LIFE INS	\$ 20.00	
TOTAL FRINGE BENEFITS			\$ 6,119.00
TOTAL STAFF and FRINGE BENEFITS			\$ 41,948.33

Budget Narrative - Describe the services that the positions will provide.

THE RESOURCE CENTER STAFF PROVIDE THE SUPERVISION OF THE YOUTH, TRANSPORTATION TO/FROM RESOURCE CENTER, COORDINATION OF CORE AND EVIDENCE BASED PROGRAM COMPONENTS, QUALITY ASSURANCE TRACKING, AND COMMUNICATION WITH THE COURT, COMMUNITY PARTNERS, AND VENDORS

Purchased or Contract Services Budget Form

COUNTY: FAIRFIELD FY24 05.06.24

FUNDING CATEGORY: Subsidy Grant

Activity Purpose: Grant Administration

LOCAL PROGRAM / ACTIVITY NAME: JDAI

<u>Agency Name/Individual</u> <u>(List all Providers by Name)</u>	<u>Public/</u> <u>Private</u>	<u>Services to be provided</u>	<u>Quantity</u>	<u>Unit</u> <u>Costs</u>	<u>Total</u>
<u>SURGE</u>	<u>PUBLIC</u>	<u>CONSULTANT FOR JDAI IMPLEMENTATION</u>	<u>1</u>	<u>\$ 50,000.00</u>	<u>\$ 50,000.00</u>
Total Purchased or Contract Services					\$ 50,000.00

Note: If the services to be provided are out-of-home placement, the facilities must either be approved by the Department of Youth Services per the minimum standards or licensed by the authorized state agency.

Program Maintenance Costs Budget Form

COUNTY: FAIRFIELD FY24 05.06.24

FUNDING CATEGORY: Subsidy Grant

Activity Purpose: Grant Administration

LOCAL PROGRAM / ACTIVITY NAME: JDAI

<u>Item Description</u>	<u>Quantity</u>	<u>Unit Cost</u>	<u>Total</u>	<u>Briefly explain the reason needed.</u>
<u>PROVISION</u>	<u>1</u>	<u>\$ 2,093.00</u>	<u>\$ 2,093.00</u>	<u>ODYS PROBATION TRANSFORMATION MEETING</u>
Total Maintenance Costs			\$ 2,093.00	

Note: If the services to be provided are out-of-home placement, the facilities must either be approved by the Department of Youth Services per the minimum standards or licensed by the authorized state agency.

Purchased or Contract Services Budget Form

COUNTY: FIELD FY24 AMENDMENT #2 05.

FUNDING CATEGORY: Y/E EVB Program Development

Activity Purpose: Program Development

LOCAL PROGRAM / ACTIVITY NAME: CAREY GUIDES, BITS, CQI, and Other

<u>Agency Name/Individual (List all Providers by Name)</u>	<u>Public/ Private</u>	<u>Services to be provided</u>	<u>Quantity</u>	<u>Unit Costs</u>	<u>Total</u>
<u>THE CAREY GROUP</u>	<u>PUBLIC</u>	<u>CAREY GUIDES, BITS, CQI</u>	<u>1</u>	<u>\$ 32,500.00</u>	<u>\$ 32,500.00</u>
<u>TRAUMA RESOURCE INSTITUTE</u>	<u>PRIVATE</u>	<u>CRM TEACHER RECERTIFICATION AND MATERIAL USE</u>	<u>1</u>	<u>\$ 300.00</u>	<u>\$ 300.00</u>
<u>THE VILLAGE NETWORK</u>	<u>PRIVATE</u>	<u>RESPIRE SERVICES, CASE MANAGEMENT</u>	<u>1</u>	<u>\$ 140.00</u>	<u>\$ 140.00</u>
Total Purchased or Contract Services					\$ 32,940.00

Note: If the services to be provided are out-of-home placement, the facilities must either be approved by the Department of Youth Services per the minimum standards or licensed by the authorized state agency.

Signature Page

Resolution No. 2024-05.21.r

A Resolution Authorizing the Approval of Amendment #2 to the FY24 Grant Agreement between Fairfield County Juvenile Court and Ohio Department of Youth Services

(Fairfield County Juvenile/Probate Court)

This resolution has not yet been voted on.

CERTIFICATE OF CLERK

It is hereby certified that the foregoing is a true and correct transcript of a resolution acted upon by the Board of County Commissioners, Fairfield County, Ohio on the date noted above.

A Resolution to Appropriate from Unappropriated Funds for the Fairfield County Law Library Resources Board (Fund 2761)[Law Library]

WHEREAS, the Fairfield County Law Library Resources Board (Fund 2761) has been awarded a grant from the State Law Library Consortium; and

WHEREAS, the grant money has been received and, therefore, it is necessary to appropriate from unappropriated funds in order to use the money for the Law Library; and

NOW THEREFORE, BE IT RESOLVED BY THE BOARD OF COUNTY COMMISSIONERS, COUNTY OF FAIRFIELD, STATE OF OHIO:

Section 1. Appropriate from unappropriated funds \$1477.38 to 12276112 Capital Outlay.

For Auditor's Office Use Only:

Section 1. Appropriate from unappropriated funds:

\$1477.38 to 12276112 574410 – Computer Hardware Equipment

Section 2. Issue an Amended Certificate and increase revenue line in Fund 2761 – Law Library \$1477.38.

Section 3. Update the receipt line item 12276112 433400 in the amount of \$1477.38.

Prepared by: Gail Beck

Signature Page

Resolution No. 2024-05.21.s

A Resolution to Appropriate from Unappropriated Funds for the Fairfield County Law Library Resources Board, Fund 2761

(Fairfield County Law Library)

This resolution has not yet been voted on.

CERTIFICATE OF CLERK

It is hereby certified that the foregoing is a true and correct transcript of a resolution acted upon by the Board of County Commissioners, Fairfield County, Ohio on the date noted above.

2024-05.21.t

A resolution to approve Conditional Acceptance of Chesapeake Section 1 Subdivision [Regional Planning]

WHEREAS, the developer of the Chesapeake Section 1 subdivision, Violet Township, has completed the public improvements in accordance with the approved construction drawings,

NOW THEREFORE, BE IT RESOLVED BY THE BOARD OF COUNTY COMMISSIONERS, COUNTY OF FAIRFIELD, STATE OF OHIO:

Section 1. That this Board hereby grants conditional acceptance of the public improvements for Chesapeake Section 1 subdivision, subject to the three-year maintenance requirements.

Prepared by: Holly Mattei
cc: Regional Planning

Signature Page

Resolution No. 2024-05.21.t

A Resolution to Approve Conditional Acceptance of Chesapeake Section 1
Subdivision

(Fairfield County Regional Planning Commission)

This resolution has not yet been voted on.

CERTIFICATE OF CLERK

It is hereby certified that the foregoing is a true and correct transcript of a resolution acted upon by the Board of County Commissioners, Fairfield County, Ohio on the date noted above.

A resolution approving the disposal of 13 disabled vehicles.

WHEREAS, Ohio Revised Code 307.12 allows the county to dispose of unneeded, obsolete or unfit property; and

WHEREAS, the Fairfield County Sheriff’s Office has 13 disabled vehicles that have a total value under \$3000.00; and

WHEREAS, the Fairfield County Sheriff’s Office has 13 disabled vehicles that are no longer useful for their operation, and

WHEREAS, the Fairfield County Sheriff’s Office desires to salvage these vehicles to A&L Towing and Recovery LLC, and

<u>YR</u>	<u>Make/Model</u>	<u>Color</u>	<u>VIN</u>
2008	Dodge Avenger	Black	1B3CC4FD1AN122880
2008	Ford Explorer	Silver	1FMEU73E68UB14272
2008	Ford Taurus	Silver	1FAHP24W98G177325
2009	Dodge Charger	Black	2B3KA43V89H620755
2011	Dodge Charger	Black	2B3CL1CGXBH599962
2012	Dodge Charger	Black	2C3CDXAG9CH241100
2013	Dodge Charger	Black	2C3CDXAG7DH648026
2014	Dodge Charger	Black	2C3CDXAG3EH279537
2014	Dodge Charger	Black	2CSCDXAG6EH287700
2015	Dodge Charger	Black	2C3CDXAG8FH836749
2016	Dodge Charger	Black	2C3CDXAG1GH251836
2016	Dodge Charger	Black	2C3CDXAG3GH251837
2017	Ford Explorer	Black	1FM5K8ARXHGD22798

A resolution approving the disposal of 13 disabled vehicles.

NOW THEREFORE, BE IT RESOLVED BY THE BOARD OF COUNTY COMMISSIONERS, COUNTY OF FAIRFIELD, AND STATE OF OHIO:

Section 1. That the Fairfield County Board of Commissioners hereby approves the disposal of the 13 vehicles for \$2950 and will sign over the title to A&L Towing and Recovery LLC, 421 Quarry Road SE, Lancaster, OH 43130

Section 2. That the Administrative Assistant of the Board of Commissioners will complete proper paper work regarding the Title and the inventory.

Prepared by: Elisa Dowdy
cc: Sheriff / Finance Supervisor

Signature Page

Resolution No. 2024-05.21.u

A Resolution Approving the Disposal of Thirteen Disabled Vehicles

(Fairfield County Sheriff)

This resolution has not yet been voted on.

CERTIFICATE OF CLERK

It is hereby certified that the foregoing is a true and correct transcript of a resolution acted upon by the Board of County Commissioners, Fairfield County, Ohio on the date noted above.

A resolution approving an account-to-account transfer into a major expenditure object category.

WHEREAS, appropriations are needed to cover expenses for 2024; and

WHEREAS, an account-to-account transfer will allow proper classification of major expenditure object categories.

NOW THEREFORE, BE IT RESOLVED BY THE BOARD OF COUNTY COMMISSIONERS, COUNTY OF FAIRFIELD, STATE OF OHIO:

Section 1. That the transfer of appropriations are hereby authorized as follows:

From: 23100101 Contractual Services
To: 23100101 Capital Outlay 17,000.00

From: 23100101 Fringe Benefits
To: 23100101 Capital Outlay 5000.00

Prepared by: Mendi Rarey
cc: Sheriff

**Account-to-Account Transfer
For Auditor's Office Use Only:**

Total Transfer of Appropriations \$22,000

From: 23100101 543000; Repair and Maintenance

To: 23100101 574200; Vehicles 17,000.00

From: 23100101 521000; Health Insurance

To: 23100101 574000; Equipment; \$5000.00

Signature Page

Resolution No. 2024-05.21.v

A Resolution Approving an Account-to-Account Transfer into a Major Expenditure
Object Category

(Fairfield County Sheriff)

This resolution has not yet been voted on.

CERTIFICATE OF CLERK

It is hereby certified that the foregoing is a true and correct transcript of a resolution acted upon by the Board of County Commissioners, Fairfield County, Ohio on the date noted above.

A resolution authorizing the approval of repayment of an advance to the General Fund from Fund 2503 Police Revolving.

WHEREAS, The Fairfield County Sheriff's Office requested an advance for Fund 2503 Police Revolving; and

WHEREAS, an advance was approved by Resolution No. 2024-01.30.q; and

WHEREAS, the monies have been collected and deposited to make repayment to the General Fund Advance.

NOW THEREFORE, BE IT RESOLVED BY THE BOARD OF COUNTY COMMISSIONERS, COUNTY OF FAIRFIELD, STATE OF OHIO:

Section 1. Request that the Fairfield County Auditor repay the following advance:

FROM: 2503 090001 Police Revolving Fund Repay Advance
<\$37,000.00>

TO: 1001 223000 General Fund Repay Advance \$37,000.00

Prepared by: Elisa Dowdy
cc: Sheriff

Signature Page

Resolution No. 2024-05.21.w

A resolution authorizing the approval of repayment of an advance to the General Fund from Fund 2503 Police Revolving

(Fairfield County Sheriff)

This resolution has not yet been voted on.

CERTIFICATE OF CLERK

It is hereby certified that the foregoing is a true and correct transcript of a resolution acted upon by the Board of County Commissioners, Fairfield County, Ohio on the date noted above.

A resolution authorizing the approval of repayment of an advance to the General Fund from Fund 2593 Concealed Handgun License.

WHEREAS, The Fairfield County Sheriff's Office requested advances for Fund 2593 Concealed Handgun License; and

WHEREAS, advances were approved by Resolution Nos. 2023-02.28.p, 2023-04.25.x, 2023-05.30.k, and 2023-06.27.bb ; and

WHEREAS, the monies have been collected and deposited to make repayment to the General Fund Advance.

NOW THEREFORE, BE IT RESOLVED BY THE BOARD OF COUNTY COMMISSIONERS, COUNTY OF FAIRFIELD, STATE OF OHIO:

Section 1. Request that the Fairfield County Auditor repay the following advance:

FROM: 2593 090001 Concealed Handgun License Repay Fund Advance
<\$15,000.00>

TO: 1001 223000 General Fund Repay Advance \$15,000.00

Prepared by: Elisa Dowdy
cc: Sheriff

Signature Page

Resolution No. 2024-05.21.x

A resolution authorizing the approval of repayment of an advance to the General Fund from Fund 2593 Concealed Handgun License

(Fairfield County Sheriff)

This resolution has not yet been voted on.

CERTIFICATE OF CLERK

It is hereby certified that the foregoing is a true and correct transcript of a resolution acted upon by the Board of County Commissioners, Fairfield County, Ohio on the date noted above.

2024-05.21.y
A resolution authorizing the approval to extend the repayment date of an advance of funds – Fund #7830 SF 8312 DLEF Grant- South Central Ohio Major Crimes Unit

WHEREAS, the General Fund approved an advance of \$40,000.00 (resolution 2023-08.22.s) for Fund 7830 SF 8312; and

WHEREAS, reimbursement has been submitted, but not yet received monies; and

WHEREAS, the Commissioners' Office would like to extend the repayment date of Fund 7830 Advance from 3/15/24 to 12/1/24 ; and

NOW THEREFORE, BE IT RESOLVED BY THE BOARD OF COUNTY COMMISSIONERS, COUNTY OF FAIRFIELD, STATE OF OHIO:

Section 1. That the Fairfield County Board of Commissioners extend the repayment date to 12/1/24 for:

DLEF Grant (Fund #7830) SF8312

Prepared by: Megan Poling MCU

Signature Page

Resolution No. 2024-05.21.y

A Resolution Authorizing the Approval to Extend the Repayment Date of an Advance of Funds, Fund #7830, Sub Fund #8312 DLEF Grant

(South Central Major Crimes Unit)

This resolution has not yet been voted on.

CERTIFICATE OF CLERK

It is hereby certified that the foregoing is a true and correct transcript of a resolution acted upon by the Board of County Commissioners, Fairfield County, Ohio on the date noted above.

2024-05.21.z

A resolution to approve the contract award for the Little Walnut Generator and Transfer Switch Project; Utilities Fund 5044 Sewer

WHEREAS, the Fairfield County Utilities Department received bids for the Little Walnut Generator and Transfer Switch Project on February 23, 2024; and

WHEREAS, the low bidder was BW Electrical Services, LLC., with a bid price of \$156,756.00 which was less than the engineer's estimate of \$158,500.00; and

WHEREAS, the Director of Utilities has reviewed the bids and recommends the award of the Little Walnut Generator and Transfer Switch project to BW Electrical Services, LLC; and

NOW THEREFORE, BE IT RESOLVED BY THE BOARD OF COUNTY COMMISSIONERS, COUNTY OF FAIRFIELD, STATE OF OHIO:

Section 1. That the Board of Fairfield County Commissioners concurs with the recommendations of the Director of Fairfield County Utilities and authorizes itself to execute Contract Documents with BW Electrical Services, LLC., to perform the work necessary to construct the Little Walnut Generator and Transfer Switch Project for the sum of \$156,756.00.

Section 2. That the Director of Fairfield County Utilities is directed to manage and administer the Contract and sign all appropriate documents up to the approved Contract Amount in an expeditious manner.

Prepared by: Joshua T.C. Anders
cc: Utilities Department

FAIRFIELD COUNTY UTILITIES
6670 LOCKVILLE ROAD
CARROLL, OH 43112
740.652.7120

Sealed proposals will be received in the Fairfield County Utilities Office, 6670 Lockville Road, Carroll, Ohio 43112 until 10:00 a.m. on February 23, 2024, and publicly opened and read at that hour and place, for the purchase, delivery, and set up service of:

LITTLE WALNUT WATER RECALMATION GENERATOR AND TRANSFER SWITCH

Copies of the Bid Specifications, Bid Form, and Contract Documents are available from the Fairfield County Utilities Department.

Bids must be submitted on the Bid Form provided and submitted in a sealed envelope marked:

BID FOR:

**FAIRFIELD COUNTY, OHIO
LITTLE WALNUT WATER RECALMATION GENERATOR AND TRANSFER SWITCH**

Failure to submit bid proposals in conformance with the Contract Documents will result in a nonresponsive bid.

Bids shall be accompanied by a Certified Check or Bid Bond in the amount of 10% of the Total Bid as a guarantee that if the Bid is accepted, a Contract will be entered into.

A Performance and Payment Bond must be furnished by the Bidder who is awarded the Contract for the full amount of the Contract to guarantee his/her faithful performance of the Contract.

The Board of Fairfield County Commissioners may reject any or all of the bids on any basis and without disclosure of a reason. The failure to make such a disclosure shall not result in accrual of any right, claim, or cause of action by any unsuccessful bidder against the Board of Fairfield County Commissioners.

Advertising Dates:

February 1, 2024
February 8, 2024

Authorized By:

Tony J. Vogel, P.E.
Director

ADVERTISEMENT FOR BIDDERS

1. Copies of the Bid Specifications, Bid Form, and Contract Documents are available in the Fairfield County Utilities Office, 6670 Lockville Road Carroll, OH 43112 or website <https://www.co.fairfield.oh.us/util/>
2. Complete sets of Bidding Documents must be used in preparing Bids. Fairfield County Utilities does not assume any responsibility for errors or misinterpretations resulting from the use of incomplete sets of Bidding Documents.
3. In making copies of Bidding Documents available on the above terms, Fairfield County Utilities do so only for the purpose of obtaining bids for the equipment and do not confer a license or grant for any other use.
4. Each bidder shall submit with his bid, a bid guaranty in the form of a bond, certified check, cashier's check, or letter of credit in the amount of 10% of the bid in accordance with Ohio Revised Code Section 153.54. The form of the bond shall be in accordance with the requirements of Ohio Revised Code Section 153.54.
5. The successful bidder will be required to post a performance and payment bond in the amount of 100% of the bid award amount as contract security.
6. Bids shall be delivered in sealed envelopes to:

Director of Utilities
Fairfield County Utilities Department
c/o Fairfield County Utilities
6670 Lockville Road
Carroll, Ohio 43112
7. All Bids must be *SEALED* and *conspicuously* marked FARFIELD COUNTY LITTLE WALNUT WATER RECALMATION GENERATOR AND TRANSFER SWITCH on the OUTSIDE of the envelope.
8. The Utilities Director reserves the right to reject any or all bids, waive any informality in same, or to accept any bid or combination of bids deemed most advantageous to the County's interest.
9. Contracts for equipment under this bid will obligate the bidder to comply with federal, state, and local laws, statutes, and ordinances including licensing of Contractors, wage rates, and non-discriminating hiring practices.
10. The solicitation for bids may be cancelled by the Fairfield County Utilities Department, and any bid or proposal may be rejected in whole or in part when it is in the best interests of Fairfield County. Fairfield County Utilities Department reserves the right to accept or reject any or all bids and to waive any irregularities in the bidding procedure.
11. By Tony J Vogel, PE, Director.
12. Location of advertisements:

Lancaster Eagle Gazette

INSTRUCTION TO BIDDERS

1. Each bidder shall include in the bid a detailed account of his experience, skill, financial standing, and equipment available to provide the equipment. Each bid must contain evidence of bidder's qualification to do business in the State of Ohio.
2. Fairfield County Utilities Department may make investigations to determine the ability of the bidder to perform the work. When required, the bidder shall present evidence of his experience in similar work and that he has the necessary equipment and financial resources to provide materials and complete the work in a satisfactory manner in the time specified.
3. Fairfield County Utilities Department reserves the right to reject any bidder who is in default on any debt or Contract or is defaulter as surety upon same or has failed to perform faithfully and efficiently any previous Contract.
4. Complete sets of bidding documents must be used in preparing bids; Fairfield County Utilities Department does not assume any responsibility for errors or misinterpretations resulting from the use of incomplete sets of bidding documents.
5. In making copies of bidding documents available on the above terms, Fairfield County Utilities Department do so only for the purpose of obtaining bids for the equipment and do not confer a license or grant for any other use.
6. Bidders shall submit a bid on a lump sum price basis for each item of equipment listed in the bid schedule.
7. The total of all prices will be determined as the sum of the products of the quantity of each item and the unit price bid for the item.
8. All questions about the meaning or intent of the bidding documents are to be submitted to Fairfield County Utilities Department in writing. Interpretations or clarifications considered necessary by Fairfield County Utilities Department in response to such questions will be issued by Addenda and delivered to all parties recorded by Fairfield County Utilities Department as having received the bidding documents. Questions received less than ten days prior to the date for opening of bids may not be answered. Only questions answered by Addenda will be binding. Oral and other interpretations or clarifications will be without legal effect. Addenda may be issued to clarify, correct, or change the bidding documents as deemed advisable by Fairfield County Utilities Department. Bidders shall list on the bid form all addenda.
9. The following items shall be used without variation by all bidders and submitted with the bid.
 - a. Instructions to the bidder
 - b. Lump sum price proposal form
 - c. Bid guaranty and contract bond
 - d. Non-collusion affidavit
10. Bids shall be signed with the name typed below the signature. If the bidder is a corporation, bid shall be signed with the legal name of the corporation, followed by the legal signature of an officer authorized to bind the corporation to a contract. If other than a President or Vice President, a copy of the authorization from the Board of Directors shall be attached. If the bidder is a partnership, full names and addresses of each partner must be given; the bid shall be signed by the number of partners required to bind the partnership of the partners, using the term "Partner". If the bidder is an individual, he shall use either the term "doing business as Builder" or "Sole Owner".
11. Each bidder shall submit with the bid a bid guaranty in the form of a bond, certified check, cashier's check, or letter of credit in the amount of 10% of the bid in accordance with Ohio Revised Code Section 153.54. The form of the bond shall be in accordance with the requirements of Ohio Revised Code Section 153.54.
12. The bid security of the successful bidder will be retained until such bidder has executed the contract documents, furnished the required contract security and met the other conditions of the Notice of Award, whereupon the bid security will be returned. If the successful bidder fails to execute and deliver the contract documents and furnishes the required contract security within 10 days after the Notice of Award, Fairfield

County Utilities Department may annul the Notice of Award and the bid security of that bidder will be forfeited. The bid security of other bidders whom Fairfield County Utilities Department believes to have a reasonable chance of receiving the award may be retained by Fairfield County Utilities Department until the earlier of seven days after the effective date of the Agreement or 60 days after the bid opening, whereupon bid security furnished by such bidders will be returned. Bid security of other Bidders whom Fairfield County Utilities believes do not have a reasonable chance of receiving the award will be returned within seven days after the Bid opening.

13. The failure or omission of any bidder to receive or examine any forms, instruments, or document, or visit the site and acquaint himself with the conditions there existing shall in no way relieve any bidder from any obligation with respect to his bid.
14. Complete in full the attached Non-Collusion Affidavit. Form shall be signed by the same person authorized to sign bids.
15. Contracts for equipment under this proposal will obligate the contractors and subcontractors not to discriminate in employment practices.
16. Bidders must, if requested, submit a compliance report concerning their employment practices and policies in order to maintain their eligibility to receive the award of the contract.
17. Corporations not chartered in Ohio shall include an affidavit executed by an officer of the corporation stating that the corporation has conformed to the provisions of the Revised Code of the State of Ohio and obtained a certificate authorizing it to do business in the State of Ohio. Certificates or copies of them shall be obtained from the office of the Secretary of State, Columbus, Ohio.
18. Bids shall be submitted no later than the date and time prescribed and at the place indicated in the advertisement or invitation to bid and shall be enclosed in an opaque sealed envelope plainly marked with the project title (and, if applicable, the designated portion of the Project for which the bid is submitted), the name and address of bidder, and shall be accompanied by the bid security and other required documents. If a Bid is sent by mail or other delivery system, the sealed envelope containing the Bid shall be enclosed in a separate envelope plainly marked on the outside with the notation "BID ENCLOSED". Bids shall be delivered to:

Utilities Director
Fairfield County Utilities Department
6670 Lockville Road
Carroll, Ohio 43112
19. No oral or telegraphic bids will be accepted.
20. Bids submitted early may be withdrawn by the bidder by written request signed by the person signing the bid. Such request must be received by the party receiving bids prior to the bid receipt deadline time.
21. A bid may be modified or withdrawn by an appropriate document duly executed in the manner that a bid must be executed and delivered to the place where Bids are to be submitted prior to the date and time of the opening of bids.
22. If within 48 hours after bids are opened any bidder files a duly signed written notice with Fairfield County Utilities Department and promptly thereafter demonstrates to the reasonable satisfaction of Fairfield County Utilities Department that there was a material and substantial mistake in the preparation of its bid, in accordance with provisions of ORC Section 9.31, that bidder may withdraw its bid, and the bid security will be returned. Thereafter, if the Equipment is re-bid, that bidder will be disqualified from further bidding on the work.
23. Bids will be opened at the time and place indicated in the Advertisement for Bids and read aloud publicly. An abstract of the amounts of the base bids and major alternates, if any, will be made available to bidders after the opening of bids.
24. Fairfield County Utilities Department reserves the right to reject any or all bids, including without limitation, nonconforming, non-responsive, unbalanced, or conditional bids. Fairfield County Utilities Department further reserves the right to reject the bid of any bidder whom it finds, after reasonable inquiry and evaluation, to be non-responsible. Fairfield County Utilities Department may also reject the bid of any bidder if Fairfield

County Utilities Department believes that it would not be in the best interest of the project to make an award to that bidder. Fairfield County Utilities Department also reserves the right to waive all informalities not involving price, time, or changes in the work and to negotiate contract terms with the successful bidder.

25. More than one bid for the same work from an individual or entity under the same or different names will not be considered. Reasonable grounds for believing that any bidder has an interest in more than one bid for the work may be cause for disqualification of that bidder and the rejection of all bids in which that bidder has an interest.
26. In evaluating bids, Fairfield County Utilities Department will consider whether or not the bids comply with the prescribed requirements, and such alternates, unit prices and other data, as may be requested in the bid form or prior to the Notice of Award.
27. In evaluating Bidders, Fairfield County Utilities Department will consider the qualifications of bidders and may consider the qualifications and experience of subcontractors, suppliers, and other individuals, or entities proposed for those portions of the work for which the identity of subcontractors, suppliers, and other individuals or entities must be submitted.
28. Fairfield County Utilities Department may conduct such investigations, as Fairfield County Utilities deems necessary to establish the responsibility, qualifications, and financial ability of bidders, proposed subcontractors, suppliers, individuals, or entities to perform the work in accordance with the contract documents. Fairfield County Utilities Department may conduct discussions with offerors who submit a proposal for the purpose of clarification or corrections regarding a proposal to ensure full understanding of, and responsiveness to, the requirements specified in the request for proposals
29. If the contract is to be awarded, Fairfield County Utilities will award the contract to the bidder whose bid is in the best interests of the project.
30. Acceptance of a Bid shall not constitute an agreement between the Fairfield County Utilities Department and bidder, and shall not be binding upon the Fairfield County Utilities unless and until an agreement covering all conditions and provisions of the work has been reduced to writing and executed by both parties.

PROJECT CONDITIONS

1. The project includes all equipment items as set forth in the bid proposal and the plans. The Bid award shall be based on the lowest and best total contract price as set forth in the Bid Proposal. Unit prices shall be used for the purposes of additions or deletions during construction.
2. The Contractor shall furnish insurance for the life of the Contract, as follows:
 - a. Workers Compensation Insurance – The insurance shall cover all employees of the Contractor or any subcontractors working on the program and shall meet all Ohio Worker’s Compensation requirements.
 - b. Public Liability Insurance – The insurance shall be in the amount not less than \$100,000 for injuries, including wrongful death, to any one person and in the amount of not less than \$1,000,000 for damages on account of any one accident.
 - c. Property Damage Insurance – The insurance shall be in the amount of not less than \$250,000 for damages on account of any one accident and in the amount of not less than \$500,000 for damages on account of all accidents.
 - d. The Contractor shall be responsible for any and all damages and injuries caused by the Contractor’s operations. Insurance on motor vehicles shall include hired carrier endorsement and non-owner coverage. Contractor represents that all insurance, as required by this section, is provided for.
3. Payments shall be made to the Contractor upon the completion of work within thirty (30) days of receipt by the County of the invoice.

4. Failure of the Contractor to perform the service of this Contract in accordance with the above regulations or any failure, in the judgment of the County, to properly operate, provide service, or execute this contract, shall be cause for cancellation of the Contract, upon thirty (30) days written notice, by the County.
5. Upon thirty (30) days written notice to the Contractor, the County may without cause and without prejudice to any other right or remedy of the County, elect to terminate the contract. In such case, Contractor will be paid for the completed and acceptable work executed in accordance with the Contract Documents prior to the effective date of the termination. The Contractor shall not be paid on account of loss of anticipated profits or revenue or other economic loss arising out of or resulting from such termination.
6. The Performance/Payment Bond, Affidavit of Personal Property Tax Liability, Affidavit of Lien Release, Experience Record, and Non-Collusion Affidavit are an integral part of the Contract.
7. Pages 1 – 5 – Specifications for EMERGENCY STANDBY GENERATOR WITH INSTALLATION SERVICES January 2024 are hereby included in full to the Project Conditions.

LUMP SUM PRICE PROPOSAL FORM

Having examined the contract documents entitled: **LITTLE WALNUT WATER RECALMATION GENERATOR AND TRANSFER SWITCH** prepared by Fairfield County Utilities Department for the said project, and having inspected the site of, and the conditions affecting and governing the construction of said project, the undersigned hereby proposes to furnish all equipment and services specified and described in the said specifications and as shown in the said drawings for the said equipment for the consideration of the following sum:

From: BW Electrical Services, LLC
 Name of Bidder

7099 Huntley Road, Ste 103

Columbus, Ohio
 Address, City, State & Zip of Bidder

440-382-6027
 Area Code & Telephone Number of Bidder

THE BID IS SUBMITTED TO:

Director of Utilities
Fairfield County Utilities
6670 Lockville Road
Carroll, Ohio 43112

The undersigned bidder proposes and agrees, if this Bid is accepted, to enter into an agreement with Fairfield County Utilities in the form included in the bidding documents to perform all work as specified or indicated in the bidding documents for the prices and for the times indicated in this bid and in accordance with the other terms and conditions of the bidding documents.

Bidder accepts all of the terms and conditions of the Advertisement for Bids and Instructions to Bidders, including without limitation those dealing with the disposition of bid security. The bid will remain subject to acceptance for 90 days after the Bid opening, or for such longer period of time that bidder may agree to in writing upon request of Fairfield County Utilities.

In submitting this bid, bidder represents, as set forth in the agreement, that:

Bidder has examined and carefully studied the bidding documents, the other related data identified in the bidding documents, and the following addenda, receipt of all which is hereby acknowledged.

Addendum No.	Addendum Date	Received By
<u>1</u>	<u>2/20/24</u>	<u>SCOTT</u>

Bidder has visited the site and become familiar with and is satisfied as to the general, local site conditions that may affect cost, progress, and performance of the work.

Bidder is familiar with and is satisfied as to all federal, state, and local Laws and Regulations that may affect cost, progress, and performance of the Work.

Bidder has obtained and carefully studied (or assumes responsibility for having done so) all additional or supplementary examinations, investigations, explorations, tests, studies and data concerning conditions (surface, subsurface and Underground Facilities) at or contiguous to the site which may affect cost, progress, or performance of the work or which relate to any aspect of the means, methods, techniques, sequences, and procedures of

construction to be employed by bidder, including applying the specific means, methods, techniques, sequences, and procedures of construction expressly required by the bidding documents to be employed by bidder, and safety precautions and programs incident thereto.

Bidder does not consider that any further examinations, investigations, explorations, tests, studies, or data are necessary for the determination of this bid for performance of the work at the price(s) bid and within the times and in accordance with the other terms and conditions of the Bidding Documents.

Bidder is aware of the general nature of work to be performed by Fairfield County Utilities and others at the site that relates to the work as indicated in the bidding documents.

Bidder has correlated the information known to bidder, information and observations obtained from visits to the site, reports and drawings identified in the bidding documents, and all additional examinations, investigations, explorations, tests, studies, and data with the bidding documents.

Bidder has given Fairfield County Utilities written notice of all conflicts, errors, ambiguities, or discrepancies that bidder has discovered in the bidding documents, and the written resolution thereof by Fairfield County Utilities is acceptable to bidder.

The bidding documents are generally sufficient to indicate and convey understanding of all terms and conditions for the performance of the work for which this Bid is submitted.

Work shall commence within ten (10) days of signing the Contract.

Bidder further represents that this bid is genuine and not made in the interest of or on behalf of any undisclosed individual or entity and is not submitted in conformity with any agreement or rules of any group, association, organization or corporation; bidder has not directly or indirectly induced or solicited any other bidder to submit a false or sham bid; bidder has not solicited or induced any individual or entity to refrain from bidding; and bidder has not sought by collusion to obtain for itself any advantage over any other bidder or over Fairfield County Utilities Department.

Bidder will complete the work in accordance with the contract documents for the following price(s):

BASE BID

1. Supply equipment as detailed in the Project Requirements.

TOTAL BASE BID

One Hundred fifty six thousand seven Hundred fifty six dollars Dollars
(In words)

\$ 156,756.00
(In figures)

In submitting this proposal, it is understood that the right is reserved by Fairfield County Utilities Department to reject any and all bids, or part of any bid, and it is agreed that the proposal may not be withdrawn for a period of thirty (30) days subsequent to the opening of bids without consent of Fairfield County Utilities Department.

If bidder is an individual

Name (typed or printed): _____

By: _____

(Individual's signature)

Doing business as: _____

Business address: _____

Phone No.: _____ Fax No.: _____

If bidder is a partnership

Partnership Name: _____

By: _____

(Signature of general partner -- attach evidence of authority to sign)

Name (typed or printed): _____

Business address: _____

Phone No.: _____ FAX No.: _____

If bidder is a corporation

Corporation Name: BW Electrical Services, LLC

State of Incorporation: NJ

By: 

(Signature -- attach evidence of authority to sign if other than President or Vice President)

Name (typed or printed): Paul Fettuccia

Title: Vice President

Business address: 7099 Huntley Road, Ste 103

Columbus, Ohio

Phone No.: 518-292-6505 FAX No.: 518-292-6507

BID GUARANTY AND CONTRACT BOND
(SECTION 153.571 Ohio Revised Code)

KNOW ALL MEN BY THESE PRESENTS, that we, the undersigned _____

(Name and address)

as Principal and _____
(Name of Surety)

_____ as Surety, are hereby held and firmly bound unto the Owner, hereinafter called the Obligee in the penal sum of the dollar amount of the bid submitted by the Principal to the Obligee on _____ to undertake the project known as: _____

The penal sum referred to herein shall be the dollar amount of the Principal's bid to the Obligee, incorporating any additive or deductive alternate proposals made by the Principal on the date referred to above the Obligee, which are accepted by the Obligee. In no case shall the penal sum exceed the amount of _____ dollars (\$ _____). For the payment of the penal sum well and truly to be made, we hereby jointly and severally bind ourselves, our heirs, executors, administrators, successors, and assigns.

THE CONDITION OF THE ABOVE OBLIGATION IS SUCH, that whereas the above named Principal has submitted a bid on the above referred to project;

NOW, THEREFORE, if the Obligee accepts the bid of the Principal and the Principal fails to enter into a proper Contract in accordance with the bid, plans, details, specifications, and bills of material; and in the event the Principal pays to the Obligee the difference not to exceed ten percent of the penalty hereof between the amount specified in the bid and such a larger amount for which the Obligee may in good faith Contract with the next lowest bidder to perform the work covered by the bid; or in the event the Obligee does not award the Contract to the next lowest bidder and resubmits the project for bidding, the Principal will pay the Obligee, not to exceed ten percent of the penalty hereof, the costs, in connection with the resubmission of printing new Contract Documents, required advertising and printing and mailing notices to prospective bidders, whichever is less, then this obligation shall be void, otherwise to remain in full force and effect. If the Obligee accepts the bid of the Principal and the Principal within ten days after the awarding of the Contract, enters into a proper Contract in accordance with the Bid, plans, details, specifications and bills of material, which said Contract is made a part of this bond the same as though set forth herein; and

IF THE SAID Principal shall well and faithfully perform each and every condition of such Contract; and indemnify the Owner against all damage suffered by failure to perform such Contract according to the provisions thereof and in accordance with the plans, details, specifications, and bills of material therefore; and shall pay all lawful claims of subcontractors, materialmen, and laborers, for labor performed and material furnished in the carrying forward, performing, or completing of said Contract; we agreeing and assenting that this undertaking shall be for the benefit of any materialman or laborer having a just claim, as well as for the Obligee herein; then this obligation shall be void; otherwise the same shall remain in full force and effect; it being expressly understood and agreed that the liability of the Surety for any and all claims hereunder shall in no event exceed the penal amount of this obligation as herein stated.

THE SAID Surety hereby stipulates and agrees that no modifications, omissions, or additions, in or to the terms of said Contract or in or to the plans and specifications therefore shall in any way affect the obligations of said Surety on this bond, and it does hereby waive notice of any such modifications, omissions or additions to the terms of the Contract or to the work or to the specifications.

NOTE: If CONTRACTOR is partnership, all partners should execute BOND.

IMPORTANT: Surety companies executing BONDS must appear on the Treasury Department's most current list (Circular 570 as amended) and be authorized to transact business in the state where the PROJECT is located.

SIGNED AND SEALED This _____ day of _____, 20 ____.

PRINCIPAL:

BY: _____

TITLE: _____

SURETY:

SURETY COMPANY ADDRESS

Street

By: _____
Attorney-in-Fact

City

State

Zip

SURETY AGENT'S ADDRESS:

Agency Name

Street

City

State

Zip

NON-COLLUSION AFFIDAVIT
(This Affidavit is part of the Proposal)

STATE OF Ohio SS:

COUNTY OF Franklin

Paolo Fettuccia being first duly sworn, deposes and says that he
is Vice President
(President, Secretary, etc.)

of BW Electrical Services, LLC the party who made the foregoing proposal; that such proposal was genuine and not collusive, the said Bidder did not collude, conspire, connive, or agree, directly or indirectly, with any bidder or person, that such other person should refrain from bidding, or submit a sham bid and did not in any manner, direct or indirectly seek by agreement or collusion, or communication or conference, with any person, to fix the bid price of Affiant or any other bidder, or to fix any overhead, profit or cost elements of said bid price, or of that of any bidder, or to secure any advantage against the Fairfield County Commissioners or any person interested in the proposed contract; and that all statements contained in said Proposal are true and further, that such Bidder did not, directly or indirectly submit this Proposal, or the contents thereof, or divulge information, or data relative thereto to any association or to any member or agent thereof.

PA AD

AFFIANT

Sworn to and subscribe before me this 22nd day of February, 2024.

[Signature]
NOTARY PUBLIC IN AND FOR

State of Ohio County, Richland

My Commission Expires April 8, 2024.

(SEAL)



SARA
JENKINS
NOTARY PUBLIC,
STATE OF OHIO
My Commission
Expires
April 8, 2024

NOTICE OF AWARD

To: _____

PROJECT DESCRIPTION: Fairfield County, Ohio, LITTLE WALNUT WATER RECALMATION GENERATOR AND TRANSFER SWITCH

Fairfield County Utilities Department has considered the bid submitted by you for the above-described WORK in response to its Advertisement for Bids advertised February 1, 2024 and February 8, 2024 and Instructions to Bidders.

You are hereby notified that your BID has been accepted for project in the amount of \$_____.

You are required by the Instruction to Bidders to execute the Agreement and furnish the required Contractor's Performance Bond, Payment Bond and certificates of insurance within ten (10) calendar days from the date of receipt of this Notice by you.

If you fail to execute said Agreement and to furnish said BONDS within ten (10) days from the date of receipt of this Notice, said OWNER will be entitled to consider all your rights arising out of the OWNER'S acceptance of your BID as abandoned and as forfeiture of your BID BOND. The OWNER will be entitled to such other rights as may be granted by law. You are required to return an acknowledged copy of this NOTICE OF AWARD to the OWNER.

Dated this ___ day of _____, 2024.

By: _____
Title: Director of Utilities

ACCEPTANCE OF NOTICE

Receipt of the above NOTICE OF AWARD is hereby acknowledged

by _____

this the _____ day of _____, 2024

By: _____
Title: _____

CONTRACT AGREEMENT

THIS AGREEMENT made this _____ day of _____, 2024 by and between FAIRFIELD COUNTY hereinafter called "OWNER" and BW Electrical Services doing business as an individual or a partnership as a corporation called "CONTRACTOR".

WITNESSETH: That for and in consideration of the payment and agreements hereinafter mentioned:

1. The CONTRACTOR will commence with the **LITTLE WALNUT WATER RECALMATION GENERATOR AND TRANSFER SWITCH**
2. The CONTRACTOR will furnish all the materials, supplies, tools, equipment, labor, and other services necessary for the construction and completion of the PROJECT described herein.
3. The CONTRACTOR will commence the Work required by the CONTRACT DOCUMENTS within ten (10) calendar days after the date of the NOTICE TO PROCEED and will perform the Work at the times and on the days specified by the OWNER.
4. The CONTRACTOR agrees to perform all of the WORK described in the CONTRACT DOCUMENTS and comply with the terms for the sum as shown in the BID schedule.
5. The term "CONTRACT DOCUMENTS" means and includes the following:
 - a. ADVERTISEMENT FOR BIDDERS
 - b. INSTRUCTIONS TO BIDDERS
 - c. BID FORM
 - d. BID SECURITY
 - e. CONTRACT (AGREEMENT)
 - f. PROJECT CONDITIONS
 - g. CONTRACT BOND (PERFORMANCE AND PAYMENT BONDS)
 - h. NOTICE OF AWARD
 - i. NOTICE TO PROCEED
 - j. ADDENDUM

one 2/20/2024

6. The OWNER will pay the CONTRACTOR in the manner and at such times as set forth in the Project Conditions such amounts as required by the CONTRACT DOCUMENTS.
7. This AGREEMENT shall be binding upon all parties hereto and their respective heirs, executors, administrators, successors, and assigns.

8. The length of the contract period of this bid shall be 6 months after the Notice to Proceed and ending on March, 2025.

9. Failure of the CONTRACTOR to perform the service of this CONTRACT in accordance with the above regulations or any failure, in the judgment of the OWNER, to properly operate, provide service, or execute this contract, shall be cause for cancellation of the Contract, upon thirty (30) days written notice, by the OWNER.

10. Upon thirty (30) days written notice to CONTRACTOR, OWNER may without cause and without prejudice to any other right or remedy of OWNER, elect to terminate the CONTRACT. In such case, CONTRACTOR will be paid for the completed and acceptable Work executed in accordance with the CONTRACT DOCUMENTS prior to the effective date of the termination. The CONTRACTOR shall not be paid on account of loss of anticipated profits or revenue or other economic loss arising out of or resulting from such termination.

IN WITNESS WHEREOF, the parties hereto have executed, or caused to be executed by their duly authorized officials, this Contract in four (4) copies each of which shall be deemed an original on the date first above written.

OWNER: Fairfield County Board of Commissioners

By:

Name: David L. Levacy

Title: President

The forgoing Agreement is approved as to form

Fairfield County Utilities

Amy Brown-Thompson

Assistant Prosecuting Attorney

Date: _____

Tony J Vogel, PE

Utilities Director

Date: _____

CONTRACTOR:

BW Electrical Services

By: *Pl #A*

Name: Paul Fettuccia
(Please type)

Title: Vice President

By: *mls*

Name: Michael Wojtowicz
(Please type)

Title: President / CEO
(If Corporation, two officers must sign)

EMPLOYER IDENTIFICATION

Tax I.D. Number 20-4517486

Telephone Number 908-281-0660

I, Carri Brown, PhD, MBA, CGFM, County Auditor hereby certify that I am qualified and acting fiscal officer of Fairfield County, Ohio and that the amount of money to wit \$ 160,000.00, to meet the cost of foregoing Agreement between the Board of County Commissioners and BW Electrical Services, has been lawfully appropriated for the purpose of the said Agreement and the money so appropriated is on deposit (or in the process of collection) to the credit of the appropriate fund free from any previous encumbrances,

(SEAL)

By *Carri L. Brown*

Date Carri Brown, PhD, MBA, CGFM, County Auditor
5/17/2024

FAIRFIELD COUNTY UTILITIES

Specifications
For a
EMERGENCY STANDBY GENERATOR
WITH INSTALLATION SERVICES

Fairfield County Utilities

EMERGENCY STANDBY GENERATOR WITH INSTALLATION SERVICES

January 2024

Fairfield County Utilities is requesting bids for an emergency standby generator with installation services for Little Walnut Wastewater Facility located at 6805 Amanda-Northern Road NW Canal Winchester, Ohio 43110.

BIDDER INSTRUCTIONS:

The County is seeking a contractor that will be responsible for each aspect of this bid. This responsibility may include subcontracting with the understanding that the primary contractor is responsible for any and all activities of said subcontractor(s) used for the items listed in this bid.

Note: Specifications are based on known equipment. Bids for equipment not meeting the exact specification as written but which can be demonstrated to provide the needed function, reliability, maintainability, etc. are encouraged. Specifications and explanations of how items bid on fulfill the bid requirements should be included with the bid.

Exceptions: Exceptions, variances or deviations to any Specification shall be listed on a separate sheet and must be submitted with your company's bid. Any variances or deviations from these specifications for this request shall be clearly stated in your response to this IFB. This should include detailed explanations of the reason for all variances or deviations. Brochures and related literature describing the brand and type of equipment and material being bid shall also accompany the bid. All related warranty information or Material Safety and Data Sheet ("MSDS") information shall be included as part of the bid package.

PRE-BID SITE VISIT:

A **voluntary site visit** will be held at 10:30 A.M. local (Canal Winchester, Ohio) time on February 16, 2024 at 6805 Amanda-Northern Road NW Canal Winchester, Ohio 43110.

Interested Parties are encouraged to attend. Non-attendance shall not constitute grounds for non-compliance with any/all Specifications. Each bidder should limit representation at this site visit to no more than three (3) persons. No other site visit will be held.

Prior to submitting a bid, all bidders are encouraged to attend the voluntary site visit to carefully examine the sites and to become familiar with the location and conditions of which they will be obligated to work under. In addition, the site visit will allow the opportunity to accurately assess the proposed project(s), evaluate existing infrastructure, discuss logistical issues, and determine accurate measurements necessary to submit a reasonable bid.

The submission of a bid for equipment and materials, removal of existing equipment, installation of new equipment and testing services shall be considered evidence that the bidder has made such examination and is satisfied as to the condition to be encountered in performing the work and as to the requirements of the site conditions, specifications, etc.

Each bidder is responsible for informing his/her company of all aspects of work to be performed; failure to do so will not release the bidder from the obligation of fulfilling the intent of the impending contract.

GENERAL:

Contractor shall complete all work in accordance with the specifications described herein.

All phases of work shall be conducted in a professional manner and completed in accordance with the schedule established by the County. Scheduling of work shall be in coordination with Fairfield County Utilities to prevent conflicts to scheduled activities. Any work performed must not interfere with the operation.

All equipment, materials, supplies and labor are to be provided by the Contractor. All replacement materials will meet or exceed that of existing materials. All replacement equipment may be subject to review and approval by the County prior to installation.

All measurements and areas involved in this contract shall be verified in writing by the Contractor. This verification of all measurements and areas shall be submitted to the County.

All necessary permits and licenses required to complete the jobs are the responsibility of the Contractor.

The successful Contractor and his workers are cautioned to use extreme care to protect all property from damage during the course of this work. In the event of damage, the property shall be repaired at the Contractor's expense, to satisfaction of the County. Said protection, shall include but not limited to, all adjacent areas and structures such as roofing, fences, posts, sidewalks, buildings, vegetation, etc.

Contractor is responsible for maintaining a clean and safe area. Removal and disposal of all waste shall be done by the Contractor on a continuous daily basis and as soon as possible.

No debris, chemicals or other toxic materials shall be allowed to enter any of the local storm drains on site. During the working phase and upon completion of the project, the Contractor shall be responsible to remove all debris and excess material from the job sites. All work areas will be properly cleaned and returned to acceptable condition per the County. Contractor is responsible for removal and disposal of all debris associated with the job. All clean up and disposal expenses shall be included in the bid price. Disposal of all waste and debris, non-hazardous or hazardous, resulting from this project shall be in accordance with both the State of Ohio.

No additional costs or fees, including but not limited to, environmental disposal fees, pick-up or transportation fees, fuel surcharges, equipment use, etc., shall be assessed or billed to the County by the successful bidder. All costs for services as specified in this IFB shall be included in prices bid.

SPECIFICATIONS:

These specifications are the minimum requirements for equipment and installation services.

Please note: Generator is new to these locations, therefore removal services are not required.

- Provide and install one new 277/480 3 phase 300kW emergency standby (Kohler or Cummins) generator of Level 2, Class 30, Type 10 as per [NFPA 110](https://www.nfpa.org/Codes-and-Standards/All-Codes-and-Standards/List-of-Codes-and-Standards) at the location stated (<https://www.nfpa.org/Codes-and-Standards/All-Codes-and-Standards/List-of-Codes-and-Standards>).

The generator shall be diesel-fueled with an Ohio Fire [Code](http://codes.ohio.gov/oac/1301%3A7-7) compliant tanks for sized for 24 hours of continuous runtime at full load. The generator shall be Kohler or Cummins brands. (This is covered by Class 30 above, <http://codes.ohio.gov/oac/1301%3A7-7>)

The generator is to be located adjacent to the control building.

- Provide all applicable technical drawings and schematics.
- County approval is required prior to installation.
- Modify as necessary the new generator's footprint area to ensure secure mounting on a concrete pad provided by the installer.
- The generator requires sound-attenuated weather rated at or below 75 dBA.
- The generator shall have an engine block heater and battery charger; appropriate 120 volt service will need to be installed to the generator.
- The generator and Automatic Transfer Switch (ATS) shall have the following contactors: generator running, general alarm, ATS position, and generator run switch.
- Provide one new 400 Amp 3 pole Automatic Transfer Switch (ATS) that is Service Entrance Rated meeting the national electric code [NFPA 70](https://www.nfpa.org/codes-and-standards/all-codes-and-standards/list-of-codes-and-standards/detail?code=70). (<https://www.nfpa.org/codes-and-standards/all-codes-and-standards/list-of-codes-and-standards/detail?code=70>).
- The transfer switch will be installed immediately after the South Central Power incoming service and will support the entire facility.
- Provide one new Remote Annunciator Panel to be installed inside the control room.
- Provide demolition and installation of all conduit and wire required to implement new diesel generator into existing electrical system for a complete installation.
- Provide the initial testing and startup including a load bank test.
- The County will provide diesel fuel to fill the tank.
- Obtain all necessary permits and fees, including but not limited to fuel, construction, and electrical.
- All material and workmanship shall be compliant with [NFPA](https://www.nfpa.org/codes-and-standards/all-codes-and-standards/list-of-codes-and-standards/detail?code=110) Standard 110, Standard for Emergency and Standby Power Systems, 2016 Edition. (<https://www.nfpa.org/codes-and-standards/all-codes-and-standards/list-of-codes-and-standards/detail?code=110>)
- **WARRANTY AND GUARANTEES:** Equipment and materials shall be installed according to manufacturer's recommendations. Bidders shall include all manufacturers' warranty information, material quality assurance, and workmanship warranty with bid response. All equipment and materials shall be guaranteed for not less than five (5) years from the date of purchase. All workmanship shall be satisfactory in accordance with the County's specifications and guaranteed for not less than one (1) year from the date of installation.
- All work will meet existing Standards and Codes for the National Electric Code. Service (OUPS) before digging at any location. (<https://www.nfpa.org/codes-and-standards/all-codes-and-standards/list-of-codes-and-standards/detail?code=70>)

INFORMATION AND QUESTIONS

All communications/questions concerning this IFB must be submitted in writing. Written responses will be prepared by the County. Changes to this IFB will be made only by formal written correspondence issued by the County.

Bidders shall not communicate with anyone from the County regarding this IFB except as specifically provided within the documents, from the time of release of the solicitation until an award has been made. Failure to do so, may result in disqualification.

Deadline for questions: No later than 4:00 P.M. on February 19, 2024. County response to all questions received will be posted to County Utilities' website no later than the close of business on February 21, 2024.

SITE LOCATION

Little Walnut Water Reclamation Facility - 6805 Amanda-Northern Road NW Canal Winchester, Ohio 43110



ORIGINAL

Carri L. Brown, PhD, MBA, CGFM

Purchase Order

Fairfield County Auditor
210 East Main Street
Lancaster, Ohio 43130

Fiscal Year 2024

Page: 1 of 1

**THIS NUMBER MUST APPEAR ON ALL INVOICES,
PACKAGES AND SHIPPING PAPERS.**

Purchase Order # **24004157 - 00**

Delivery must be made within doors of specified destination.

Expiration Date: 03/15/2025

**B
I
L
L
T
O**

FAIRFIELD COUNTY UTILITIES
6670 LOCKVILLE ROAD
CARROLL, OH 43112
Phone: 740-652-7120

Revisions: 000

**V
E
N
D
O
R**

BW ELECTRICAL SERVICES LLC
239 HOMESTEAD ROAD
HILLSBOROUGH, NJ 08844

**S
H
I
P
T
O**

OPERATIONS BUILDING-UTILITIES
6670 LOCKVILLE ROAD
CARROLL, OH 43112
Phone: 614-322-5200

VENDOR PHONE NUMBER	VENDOR FAX NUMBER	REQUISITION NUMBER	DELIVERY REFERENCE	
		4531		
DATE ORDERED	VENDOR NUMBER	DATE REQUIRED	FREIGHT METHOD/TERMS	DEPARTMENT/LOCATION
04/18/2024	18157	04/18/2024		UTILITIES-OPERATIONS
NOTES				

PO Requisitioner Name : Jody Altman

E mail Address : jody.altman@fairfieldcountyohio.gov

ITEM #	DESCRIPTION / PART #	QTY	UOM	UNIT PRICE	EXTENDED PRICE
1	SEWER BLANKET GL Account: 12504424 - 530000	1.0	EACH	\$160,000.00	\$160,000.00
2	WATER BLANKET GL Account: 12584123 - 573600	1.0	EACH	\$37,000.00	\$37,000.00
GL SUMMARY					
	12504424 - 530000			\$160,000.00	
	12584123 - 573600			\$37,000.00	

Invoice Date ___/___/___ Invoice Amount \$ _____ To Be paid ___/___/___ Warrant # _____

COUNTY AUDITOR'S CERTIFICATE

It is hereby certified that the amount \$197,000.00 required to meet the contract, agreement, obligation, payment or expenditure, for the above, has been lawfully appropriated, authorized or directed for such purpose and is in the County Treasury or in process of collection to the credit of the submitted Fund(s) free from any obligation or certification now outstanding.

Date: 04/18/2024

Carri L. Brown

Auditor Fairfield County, OH

Purchase Order Total \$197,000.00

For Department Use ONLY

Prosecutor's Approval Page

Resolution No.

A resolution to approve the contract award for the Little Walnut Generator and Transfer Switch Project; Utilities Fund 5044 Sewer

(Fairfield County Utilities Department)

Approved as to form on 5/10/2024 4:42:50 PM by Amy Brown-Thompson,



Amy Brown-Thompson
Prosecutor's Office
Fairfield County, Ohio

Signature Page

Resolution No. 2024-05.21.z

A Resolution to Approve the Contract Award for the Little Walnut Generator and Transfer Switch Project; Utilities Fund #5044, Sewer

(Fairfield County Utilities Department)

This resolution has not yet been voted on.

CERTIFICATE OF CLERK

It is hereby certified that the foregoing is a true and correct transcript of a resolution acted upon by the Board of County Commissioners, Fairfield County, Ohio on the date noted above.

A resolution authorizing the approval of payment of invoices for departments that need Board of Commissioners' approval.

WHEREAS, departments that need the Board of Commissioners' approval for payment of their invoices have submitted their invoices to the County Auditor; and

WHEREAS, the County Auditor has submitted the cash disbursement journal for payment of invoices for the check date of May 23, 2024.

NOW THEREFORE, BE IT RESOLVED, BY THE BOARD OF COUNTY COMMISSIONERS, FAIRFIELD COUNTY, STATE OF OHIO:

Section 1. That the Fairfield County Board of County Commissioners approves the attached cash disbursement journal.

Prepared by: Auditor/Finance
cc: Finance Office

INVOICES BY DEPARTMENT

05/23/2024 to 05/23/2024

Department

Check #	Check Date	Vendor #	Vendor Name	Invoice #	Invoice Date	PO #	Warrant	Line Item Description	Amount
1200			COMMISSIONERS ADMIN						
			Fund: 2876 - FISCAL RECOVERY (ARP)						
5401387	05/23/2024	4623	VILLAGE OF BALTIMORE	4	05/14/2024	23004231	C0521	subgrant agreement for Baltimore Water project	111,660.00
							TOTAL: COMMISSIONERS ADMIN		111,660.00

INVOICES BY DEPARTMENT

05/23/2024 to 05/23/2024

Department

Check #	Check Date	Vendor #	Vendor Name	Invoice #	Invoice Date	PO #	Warrant	Line Item Description	Amount
---------	------------	----------	-------------	-----------	--------------	------	---------	-----------------------	--------

Summary Total for this report: **\$111,660.00**

Commissioner Steven A. Davis

Commissioner Jeffrey M. Fix

Commissioner David L. Levacy

Date

Signature Page

Resolution No. 2024-05.21.aa

A Resolution Authorizing the Approval of Payment of Invoices for Departments that
Need Board of Commissioners Approval

(Fairfield County Commissioners)

This resolution has not yet been voted on.

CERTIFICATE OF CLERK

It is hereby certified that the foregoing is a true and correct transcript of a resolution acted
upon by the Board of County Commissioners, Fairfield County, Ohio on the date noted above.

HANDOUTS PROVIDED
BY THE PUBLIC
DURING THE
PUBLIC COMMENT
SECTION OF THE
MEETING ARE
CONTAINED
HEREAFTER





May 21, 2024

Dear Fairfield County Commissioners,

On behalf of Chambers for Innovation and Clean Energy (CICE), I am writing to underscore the significant economic benefits that large-scale solar and wind projects present for Fairfield County and the state of Ohio and urge you to consider what is at stake should a county-wide restriction be placed on their development.

CICE is a national network of chambers of commerce and economic development organizations, founded and run by chamber and economic development professionals. Our work focuses on promoting the economic benefits and energy security that clean energy projects can deliver.

We have been working in Ohio for more than eight years, over which time we have partnered with dozens of chambers, economic development organizations, and businesses and have witnessed firsthand the transformational economic impact that large-scale solar and wind projects have brought to host communities across the state.

A blanket ban would significantly restrict future economic development and opportunity for Fairfield County. These projects generate significant employment opportunities and tax revenue, stimulating economic activity across various sectors and allowing for deepened investment in critical local infrastructure projects, essential public services, and community development initiatives.

During the construction phase, these projects create hundreds of jobs, 70% of which must be filled by Ohio residents. Once operational, the projects also necessitate long-term operations and maintenance positions. Economic development and business organizations are building out programs to equip Ohio workers to take advantage of these lasting and well-paying jobs. A ban would limit local skills development and job training, ultimately putting Ohio workers at a distinct disadvantage by delaying preparedness and halting new job creation.

This impact would not only be felt in on-site job opportunities. Rather, county solar bans have ripple effects on economic growth opportunities in related sectors. Ohio is home to a booming solar manufacturing sector and the largest solar panel factory under development in the country. Local communities can leverage this moment by expanding opportunities for their engineers, electricians, technicians, operations and logistics professionals, and others in adjacent industries, including solar racking, inverters, batteries, and other component sectors.

Additionally, a ban would restrict property rights for farmers and other landowners. Solar and wind projects rely largely on willing private landowners and thus generate significant landowner payments over the project lifetime. This predictable income helps ensure that generational farms

are kept in the family rather than sold off. The option to maintain ownership of the land, secure financial stability, and return the property to agricultural use if desired after the project is decommissioned is an invaluable opportunity for many families and a fundamental exercise of property rights. Furthermore, projects are increasingly incorporating the practice of agrivoltaics, allowing for some amount of agricultural activity to continue during the project lifetime. Bans undermine farmer and landowner autonomy while deterring innovative agrivoltaic practices.

Furthermore, employers of all sizes are increasingly looking for access to renewable energy as a fundamental component of their site selection process. A ban would restrict Fairfield County from future transformative economic development opportunities.

Fairfield County stands to benefit significantly from the job creation, tax revenue generation, and broader economic development dimensions of large-scale wind and solar projects. A ban would severely limit, if not eliminate, this opportunity. Without a blanket ban in place, the county would maintain its ability to evaluate projects on a case-by-case basis.

We are ready and willing to be a resource as you continue to discuss the role of renewable energy projects in your county, and we thank you for your thoughtful consideration of this matter.

Sincerely,
Kelsey Pepitone, Clean Energy Outreach Manager

Case # 24-0495

5/17/2024

To Whom It May Concern:

This letter is to voice my concerns for the installation of industrial solar panels on our prime farm land.

We have lived here for over 50 years and the thought of having to see even one of these eyesores makes me sick. After spending my life keeping up our property to keep it having value I don't want to see it all slip away because of these eyesores. When they finally come to understand that climate change is something that we have had for thousands of years and the government money runs out, we will be stuck with these eyesores and we will have to figure out a way to clean up the mess.

There is no study to tell us if the soil will even have any productivity left in it after the topsoil is all removed and if there is anything left of our eco system. Every one in Fairfield County had always had good wells and that could easily come to an end. We could see our aquaphor drained.

Also, harmonic noise will impact our reception on our phone lines. I have many other concerns, these are just a few. I hope you just don't clutter up Fairfield County with any of these eyesores. We have a beautiful place to live and it's called Fairfield County for a reason. People will always remember what you do for our county; I hope you do the right thing.



Penelope J. George

Case # 24-0495

5/17/2024

To Whom It May Concern:

I am writing this letter to let you know of my great objection of placing industrial solar panels on our beautiful prime farm land in Fairfield County. I have seen these obnoxious eyesores and breaks my heart to think they are coming to property around me. I bought this property 30 years ago, and I have invested thousands of dollars to keep it looking good and retain value. The value will be gone if the solar panels are installed. After a few years, these companies will abandon the panels and they will fall into decay. It has not been proven that our farm land will ever be productive again after the top soil, etc. has been removed.

Our local power company has already told us that we will have rolling brown outs, and who knows how long before our aquaphor will be depleted. We have been so fortunate to have so many wonderful assets in Fairfield County and we want to keep it that way. Put your Solar Panels in the desert or somewhere where hundreds of people aren't affected. Leave our prime farmland alone.

These are only a few of my concerns.

The government money will run out. We can all count on that.



Jeffrey R. Schweitzer

CASE # 24-0495

5/20/2024

To Whom it May Concern,

I am writing this letter to voice my strong feelings against Industrial Solar Panels. According to an article (written by Richard Bigham) on Power Quality in the Electrical Contractor magazine: More incidents of power quality problems are reported to be originating from distributed Energy Resources (DERs) such as wind turbines and solar panels. More specifically, as the publications call it. Solar Panels generate DC voltage to convert DC voltage to AC voltage at the primary grid frequency (50 to 60 Hz) requires electronic components that operate similarly to the nonlinear loads that are the source of Power Quality problems, such as harmonic currents. Getting back to real Power Quality problems that have been documented. This article also states that solar and wind is 32% and when multiplied by 13% of the total power from renewable, equates to approximately to 4% of the total power sources, from such generating resources. That's a far cry from other publications stating that soon more than 80% of AC power will be preceded through these resources

This article also lists some negative features of Solar Panel farms:

- Increased voltage harmonic distortion over the IEEE 519 levels recommended, especially with higher number of paralleled panels.
- Noise on landline phone systems traced to a large solar farm
- Voltage imbalance
- Voltage stability issues with cloud transients
- Higher frequency signals where solar panel farms caused portable phones and touch -dimmer lights to malfunction

Facts from Ecowatch.com: When a solar facility is developed on farm land, most homes within 1/10th of a mile of a solar farm decline in value 7% and adverse effects extend out as far as one mile.

There are very few places in the world that has natural rich soil, water, and climate conducive for agricultural production, as Ohio. It is hard to believe that anyone would even consider using prime farm land for solar panel installation. When these prime agricultural lands are being striped and wasted on solar power, the price of food and agricultural products will increase due to demand.. According to other eco and fact finding internet sites on solar panels other negatives are water run off, erosion, pollution, disruption of the ECO systems, disturbing wildlife habitats plus being an eyesore.

When fires occur (and they do occur) in the solar panels, toxic fumes are emitted into the air. When damage does occur, and toxic waste leaks into the ground, will it leak into our streams? Who removes the toxic waste when the life of the solar panels are spent?

People live in Fairfield County for its beauty and natural resources, not to look at solar panels.

William C George
William C George

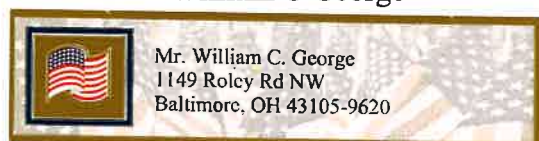

Both Sides Now?

DERs, solar and wind have an effect on PQ situations

By Richard P. Bingham

MUSIC LEGEND JONI MITCHELL “looked at life from both sides now” in the late 60s. In the power quality world, we have a similar perspective. When determining the cause of PQ problems we have two sides to consider: the electricity producer and the consumer.

Forty years ago, studies showed that most problems originated within a facility. Improper construction of the electrical infrastructure, large electrical loads starting up, the proliferation of nonlinear loads (especially when they replaced linear ones) and lack of adequate electrical equipment maintenance were and still are leading causes of power quality problems.

On the flip side, the electric utilities weren't immune from blame, as faulted power lines, failed electrical equipment and misoperation of protective equipment affected numerous customers. Overall, the statistics back then showed that the source was more likely downstream or load side than upstream or electric provider side.

Problems with DERs

There has been significant information published lately suggesting this pattern may be changing. More incidents of power quality problems are reported to be originating from distributed energy resources (DERs) such as wind turbines or solar panels. More specifically, renewable energy sources have been attributed to being the cause or aggravating the problem by the direct injection of non-steady-power, as publications call it. Some publications state that soon, more than 80% of AC power will be processed through these sources, which adds to the fear factor for the future supply quality. An unbiased look into the facts is the first step to getting a better handle on this potential problem.

According to the U.S. Energy Information Administration's “U.S. Energy Facts Explained,” the nation's primary energy consumption by source in 2022 was 13% from renewable sources. Within that category, wind was at 29%, followed by hydroelectric at 18%, then solar 14%. But biomass—which includes renewable resources such as wood—led at 37%. Biomass generates electricity in a similar manner as coal, natural gas and petroleum, and it shares the same prime mover method by converting heat from burning to generate steam to turn turbines. The rotational motion is used to spin an electric generator, producing relatively steady and basically pure sine wave voltage, due in part to the mechanical inertia of the system.

Solar and wind's voltage production

This is quite different from how solar and wind generators produce voltage. Solar panels generate DC voltage. To convert that to AC voltage at the primary grid frequency (50 or 60 Hz) requires electronic components that operate similarly to the nonlinear loads that were the source of PQ problems, such as harmonic currents. Wind

turbines are rotational prime movers, but they don't turn at a constant, reliable speed.

The AC voltage of varying frequency is first converted to DC, then back to AC at the primary grid frequency. These electronic-based generators must have their outputs precisely synced to the fairly constant grid frequency and phase angle. Their source impedance and ability to absorb negative volt-ampere reactive is different from the rotational-based electricity generators. That sounds like a basis for those waving the trouble-ahead flag. But some simple math shows that the fear is somewhat exaggerated. Solar and wind is 32%, and when multiplied by 13% of total power from renewables, equates to approximately 4% of the total power sources coming from such generating sources. That's quite a bit away from 80%.

Getting back to some real PQ problems, the following are a few that have been documented in peer-reviewed technical journals.

Solar

- Increased voltage harmonic distortion over the IEEE 519 levels recommended, especially with a higher number of paralleled panels
- Noise on landline phone systems traced to a large solar farm
- Voltage imbalance, especially with single-phase rooftop units
- Voltage stability issues with cloud transients
- System protection power reversal challenges where customers can be a load or a source of power flowing into the grid

Wind

- Wind turbines are directly affected by changing wind conditions as blades pass the towers, causing uneven power production that can propagate through the system, resulting in voltage variations that cause flicker.
- Significant levels of harmonics result from using frequency converters, thyristor controllers and capacitors, with cases of resonance, causing even larger levels.
- Some designs have a poor power factor due to reactive power, which can be an issue, and managing reactive power is essential for maintaining grid stability.

Manufacturers continue to improve their product's output, with testing and compliance to the 2018 revision of IEEE 1547 Clause 7. This revision updates and expands the power quality requirements from prior versions, including limitations on the DER contributions of current distortion, voltage fluctuations, DC current injection and temporary overvoltage.

The PQ realm has always been and will continue to include electricity generators and consumers. We just need to keep our eyes and minds open to the changing technologies.

BINGHAM, a contributing editor for power quality, can be reached at 908.499.5321.

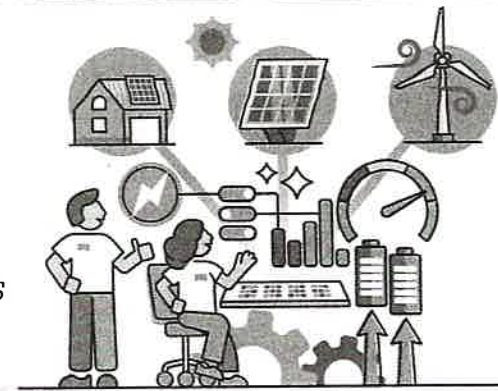

An Alternative Theory

Follow the current, part 4

By Richard P. Bingham



WHILE INVESTIGATING A MYSTERIOUS AFCI BREAKER TRIPPING and a flickering light, we considered a few possible causes but eventually found the culprit: a defective bulb. Another potential source of the problem was forgotten until a separate investigation brought it back the forefront. The source? Supraharmonics.

When I entered into the world of power quality and the instruments to measure it back in the late 1970s, harmonics were becoming worth considering as a potential source of power quality problems. Early instruments used discrete filters to measure specific harmonic frequencies, such as 180 Hz for the 3rd harmonic for a 60-Hz fundamental, 300 Hz for the 5th and so on. It soon became apparent that this wouldn't be a practical solution, as there were too many harmonic frequencies to consider for the voltage and current signals.

Using a mathematical process called the Fast Fourier Transform gained traction as instruments' microprocessors became more powerful, especially the specialized digital signal processors (DSPs). DSPs were designed to efficiently perform the needed iterative multiplication steps.

Higher switching rates

With single-phase linear loads, such as the power supplies for most information technology equipment (computers, printers, modems, etc), calculating and monitoring the odd harmonics (3rd, 5th, 7th, 9th, etc.) up to the 19th was good enough in most applications. For three-phase applications, such as adjustable-speed drives, the switching frequency of the power supplies began to get faster, requiring higher-order harmonics to be included.

For many years, the 50th harmonic was the de facto limit, being 3 kHz for 60-Hz electrical systems and 2 kHz for 50-Hz systems. As harmonic measurement and limit standards were developed, these limits were

set in stone—that is, until the technology began to advance to higher switching rates.

Higher switching rates were used in power supplies because they reduced the size of the components and magnitude of the resulting harmonic currents. However, with the dominant electric load shifting from linear to nonlinear loads, harmonic distortion was found to be the cause of PQ problems, such as overheated neutral conductors and transformers, damage to motor windings and bearings, communication errors and false trips of protection devices.

Signals in the 2–9 kHz frequency range and intraharmonics were measured. Intraharmonics are signals with frequencies between harmonic frequencies, usually caused by asynchronous conditions. This required instruments to compute 12 times more frequency bins.

Even higher frequency signals

In the second decade of the 21st century, a few papers discussed even higher frequency signals. Interference from electric vehicle charging equipment (some with 50-kHz switching or chopping frequencies) was measured on the grid, as well as distributed energy resources (photovoltaic systems, wind turbines and battery storage systems). A CNC machine was found to emit signals affecting kitchen appliances, and solar panel farms caused portable phones and touch-dimmer lights to malfunction.

This raised the bar of the frequencies of interest up to 150 kHz, and set the groups in motion to propose limits on supraharmonics, with phrases such as “levels having logarithmic

drop-off with logarithmically increasing frequency.” Once again, we get limits before we agree on how to measure them.

In the previous article on the AFCI tripping mystery, the concept of Nyquist sampling theory was briefly reviewed, revealing that the instrument used in the investigation may not have had a fast enough analog-to-digital conversion or sampling rate to accurately measure the defective bulb's signals that caused the AFCI's arc-detection algorithm to falsely trip. It turns out that pictures of the waveform distortion of supraharmonics looked very similar to those recorded from the defective bulb, except there was much more detail and a higher sampling rate.

An EV disruption

This brings us back to the beginning of this article and the quickly dismissed theory that the culprit was some source of interference from the neighborhood. With an auto body shop a block away, could it have been an arc welder? Since the residence was in the heart of Tesla territory, could a significant number of EVs charging after work result in interference as reported in one of the aforementioned studies?

Though some in the PQ industry dismiss supraharmonics as more of an academic study than a concern for electric utilities and their customers, how would we know if a substation protection system operates incorrectly and creates a blackout because of a condition no one is monitoring?

Consider what the MRIs and CT scans did for imaging inside the body compared to X-rays. As the saying goes, just because you don't see it with today's tools doesn't mean it's not out there.

BINGHAM, a contributing editor for power quality, can be reached at 908.499.5321.